

03.13-08/22/96-01719

FINAL

**REMEDIAL INVESTIGATION REPORT
OPERABLE UNIT NO. 6
(SITE 86)
VOLUME X
MARINE CORPS BASE
CAMP LEJEUNE, NORTH CAROLINA**

**CONTRACT TASK ORDER 0303
TEXT AND FIGURES**

AUGUST 22, 1996

Prepared For:

**DEPARTMENT OF THE NAVY
ATLANTIC DIVISION
NAVAL FACILITIES
ENGINEERING COMMAND
*Norfolk, Virginia***

Under:

**LANTDIV CLEAN Program
Contract N62470-89-D-4814**

Prepared by:

**BAKER ENVIRONMENTAL, INC.
*Coraopolis, Pennsylvania***

TABLE OF CONTENTS

	<u>Page</u>
EXECUTIVE SUMMARY	ES-1
1.0 INTRODUCTION	1-1
1.1 Report Organization	1-1
1.2 Background and Setting of MCB, Camp Lejeune	1-2
1.2.1 Location and Setting	1-2
1.2.2 History	1-2
1.2.3 Operable Unit Description	1-2
1.2.4 Topography	1-3
1.2.5 Surface Water Hydrology	1-3
1.2.6 Geology	1-3
1.2.7 Hydrogeology	1-4
1.2.8 Ecology	1-5
1.2.9 Land Use Demographics	1-9
1.2.10 Meteorology	1-10
1.3 Background and Setting of Site 86	1-10
1.3.1 Site Location and Setting	1-10
1.3.2 Site History	1-11
1.4 Previous Investigations	1-11
1.4.1 Preliminary Site Investigation	1-11
1.4.2 Site Assessment	1-11
1.5 Remedial Investigation Objectives	1-13
1.6 References	1-13
2.0 SITE CHARACTERISTICS	2-1
2.1 Topography and Surface Features	2-1
2.2 Surface Water Hydrology	2-1
2.3 Soil	2-1
2.4 Geology	2-1
2.5 Hydrogeology	2-3
2.5.1 Groundwater Elevation Data	2-4
2.5.2 Groundwater Flow Contour Maps	2-4
2.5.3 Hydraulic Properties	2-5
2.5.4 Groundwater Flow Velocities	2-6
2.5.5 General Groundwater Flow Patterns	2-6
2.6 Identification of Water Supply Wells	2-7
2.7 Ecology	2-7
2.8 References	2-8
3.0 STUDY AREA INVESTIGATIONS	3-1
3.1 Site Survey	3-1
3.2 Soil Investigation	3-1
3.2.1 Soil Sampling Procedures	3-2
3.2.2 Sampling Locations	3-3
3.2.3 Analytical Program	3-3

TABLE OF CONTENTS
(Continued)

	<u>Page</u>
3.2.4	Quality Assurance and Quality Control 3-4
3.2.5	Air Monitoring and Field Screening 3-5
3.3	Groundwater Investigation 3-5
3.3.1	Monitoring Well Installation 3-5
3.3.2	Monitoring Well Development 3-6
3.3.3	Water Level Measurements 3-7
3.3.4	Aquifer Testing 3-7
3.3.5	Sampling Locations 3-7
3.3.6	Sampling Procedures 3-8
3.3.7	Analytical Program 3-8
3.3.8	Quality Assurance and Quality Control 3-9
3.3.9	Field Screening and Air Monitoring 3-9
3.4	Habitat Evaluation 3-9
3.5	Decontamination Procedures 3-10
3.6	Investigation Derived Waste (IDW) Handling 3-10
3.7	References 3-10
4.0	NATURE AND EXTENT OF CONTAMINATION 4-1
4.1	Data Quality 4-1
4.1.1	Data Management and Tracking 4-1
4.2	Non-Site Related Analytical Results 4-2
4.2.1	Laboratory Contaminants 4-2
4.2.2	Naturally-Occurring Inorganic Analytes 4-3
4.3.1	Soil Investigation 4-4
4.3.2	Groundwater Investigation 4-7
4.4	Extent of Contamination 4-9
4.4.1	Extent of Soil Contamination 4-9
4.4.2	Extent of Groundwater Contamination 4-10
4.5	References 4-12
5.0	CONTAMINANT FATE AND TRANSPORT 5-1
5.1	Chemical and Physical Properties Impacting Fate and Transport 5-1
5.2	Contaminant Transport Pathways 5-2
5.2.1	Leaching of Soil Contaminants to Groundwater 5-3
5.2.2	Migration of Groundwater Contaminants 5-3
5.3	Fate and Transport Summary 5-5
5.3.1	Volatile Organic Compounds 5-5
5.3.2	Semivolatile Organic Compounds 5-6
5.3.3	Pesticides 5-6
5.3.4	Metals 5-6
5.4	References 5-7

TABLE OF CONTENTS
(Continued)

	<u>Page</u>
6.0	BASELINE HUMAN HEALTH RISK ASSESSMENT 6-1
6.1	Introduction 6-1
6.2	Hazard Identification 6-2
6.2.1	Data Evaluation and Reduction 6-2
6.2.2	Identification of Data Suitable for Use in a Quantitative Risk Assessment 6-3
6.2.3	Criteria Used in Selection of COPCs 6-3
6.2.4	Contaminants of Potential Concern (COPCs) 6-8
6.3	Exposure Assessment 6-10
6.3.1	Potential Human Receptors and Adjacent Populations 6-10
6.3.2	Migration Exposure Pathways 6-11
6.3.3	Quantification of Exposure 6-13
6.3.4	Calculation of Chronic Daily Intakes 6-15
6.4	Toxicity Assessment 6-22
6.4.1	Carcinogenic Slope Factor 6-23
6.4.2	Reference Dose 6-24
6.4.3	Lead 6-25
6.4.4	Dermal Adjustment of Toxicity Factors 6-26
6.5	Risk Characterization 6-26
6.5.1	Human Health Risks 6-27
6.6	Lead UBK Model Results 6-28
6.7	Sources of Uncertainty 6-29
6.7.1	Analytical Data Uncertainty 6-29
6.7.2	Exposure Assessment Uncertainty 6-29
6.7.3	Sampling Strategy Uncertainty 6-30
6.7.4	Toxicity Assessment Uncertainty 6-31
6.8	Conclusions of the BRA for Site 86 6-32
6.8.1	Current Scenario 6-32
6.8.2	Future Scenario 6-32
6.9	References 6-33
7.0	ECOLOGICAL RISK ASSESSMENT 7-1
7.1	Objectives, Scope, and Organization of the Ecological Risk Assessment ... 7-1
7.2	Problem Formulation 7-2
7.3	Contaminants of Potential Concern 7-2
7.3.1	Criteria for Selecting Contaminants of Potential Concern 7-2
7.3.2	Selection of Contaminants of Potential Concern 7-4
7.3.3	Physical/Chemical Characteristics of COPCs 7-5
7.4	Ecosystems Potentially at Risk 7-6
7.5	Ecological Endpoints 7-6
7.5.1	Terrestrial Endpoints 7-7
7.6	Conceptual Model 7-7

TABLE OF CONTENTS
(Continued)

	<u>Page</u>
7.6.2	Groundwater Exposure Pathway 7-8
7.6.3	Air Exposure Pathway 7-8
7.7	Exposure Assessment 7-8
7.8	Ecological Effects Characterization 7-8
7.8.1	Surface Soil 7-9
7.8.5	Terrestrial Chronic Daily Intake Model 7-9
7.9	Risk Characterization 7-11
7.9.1	Terrestrial Chronic Daily Intake Model 7-11
7.10	Ecological Significance 7-11
7.10.1	Terrestrial Receptors 7-12
7.10.3	Threatened and Endangered Species 7-12
7.10.4	Wetlands 7-12
7.11	Uncertainty Analysis 7-12
7.12	Conclusions 7-13
7.12.1	Terrestrial Receptors 7-13
7.13	References 7-14
8.0	CONCLUSIONS AND RECOMMENDATIONS 8-1
8.1	Conclusions 8-1
8.2	Recommendations 8-1

APPENDICES

A	Test Boring Records
B	Test Boring and Well Construction Records
C	Chain-of-Custody Forms
D	Field Well Development Records
E	Investigation Derived Waste Summary and Recommendations
F	Sampling Summary
G	Data and Frequency Summaries
H	Statistical Summaries
I	Field Duplicate Summaries
J	QA/QC Sampling Summary
K	Grain Size, Permeability, and TPH Analytical Results
L	Wet Chemistry Analytical Results
M	Aquifer Test Results
N	Aquifer Property Calculations
O	Base Background Analytical Results and Evaluation Report
P	Shower Model
Q	Lead UBK Model
R	Site Conceptual Model
S	CDI Calculations
T	Field Data Sheets
U	Terrestrial Reference Values and CDI Calculations

LIST OF TABLES

- ES-1 Summary of Site Contamination

- 1-1 Geologic and Hydrogeologic Units of North Carolina's Coastal Plain
- 1-2 Summary of Hydraulic Properties Unrelated Site Investigations
- 1-3 Hydraulic Property Estimates of the Castle Hayne Aquifer
- 1-4 Protected Species Within MCB, Camp Lejeune
- 1-5 Land Utilization Within Developed Areas of MCB, Camp Lejeune
- 1-6 Climatic Data Summary Marine Corps Air Station, New River
- 1-7 Summary of Well Construction Details, Site Assessment
- 1-8 Detected Organic Contaminants in Groundwater, Site Assessment
- 1-9 Remedial Investigation Objectives

- 2-1 Summary of Soil Physical Properties
- 2-2 Summary of Groundwater Elevations
- 2-3 Hydraulic Properties Summary
- 2-4 Summary of Potable Water Supply Wells

- 3-1 Soil Sampling Summary Test Borings
- 3-2 Soil Sampling Summary Monitoring Well Test Borings
- 3-3 Quality Assurance/Quality Control Sampling Program Soil Investigation
- 3-4 Summary of Well Construction Details
- 3-5 Summary of Water Level Measurements
- 3-6 Summary of Groundwater Field Parameters Round One
- 3-7 Summary of Groundwater Field Parameters Round Two
- 3-8 Groundwater Sampling Summary Round One
- 3-9 Groundwater Sampling Summary Round Two
- 3-10 Quality Assurance/Quality Control Sampling Program, Groundwater Investigation

- 4-1 Summary of Rejected Data
- 4-2 Summary of Site Contamination
- 4-3 Surface Soil -Positive Detection Summary, TCL Organics
- 4-4 Surface Soil -Positive Detection Summary, TAL Metals
- 4-5 Subsurface Soil -Positive Detection Summary, TCL Organics
- 4-6 Subsurface Soil -Positive Detection Summary, TAL Metals
- 4-7 Groundwater -Positive Detection Summary, TCL Organics
- 4-8 Groundwater -Positive Detection Summary, TAL Metals
- 4-9 Groundwater -Positive Detection Summary, Dissolved Metals

- 5-1 Organic and Chemical Physical Properties
- 5-2 Relative Mobilities of Metals as a Function of Environmental Conditions (Eh, pH)

- 6-1 Contaminants of Potential Concern in Surface Soil
- 6-2 Contaminants of Potential Concern in Subsurface Soil
- 6-3 Contaminants of Potential Concern in Groundwater
- 6-4 Summary of Exposure Dose Input Parameters
- 6-5 Summary of Exposure Pathways

LIST OF TABLES (Continued)

- 6-7 Summary of Dermal Adjusted Health-Based Criteria
- 6-8 Summary of Risks for the Military Receptor
- 6-9 Summary of Risks for the Child Trespasser
- 6-10 Summary of Risks for the Future Child Resident
- 6-11 Summary of Risks for the Adult Trespasser
- 6-12 Summary of Risks for the Future Adult Resident
- 6-13 Summary of Risks for the Construction Worker
- 6-14 Summary of Uncertainties in the Results of the Human Health Risk Assessment
- 6-15 Summary of Contaminants Contributing to Site Risks

- 7-1 Contaminants of Concern in Each Media
- 7-2 Physical/Chemical Characteristics of the COPCs
- 7-3 Frequency and Range of Contaminant Detections Compared to Soil Flora and Fauna Screening Values
- 7-4 Exposure Parameters for Chronic Daily Intake Model
- 7-5 Terrestrial Intake Model Quotient Index

LIST OF FIGURES

- 1-1 Operable Unit No. 6 - Sites 36, 43, 44, 54, and 86
- 1-2 Operable Units and Site Locations
- 1-3 Locations of Hydrogeologic Cross-Sections
- 1-4 Hydrogeologic Cross-Sections
- 1-5 Site Map, Site 86 - Above Ground Storage Tank Area
- 1-6 Site Assessment Sampling Locations

- 2-1 Cross-section Location and Approximate Surface Elevation Contour Map
- 2-2 Geologic Cross-sections A-A' through F-F'
- 2-3A Groundwater Elevation Trends
- 2-3B Groundwater Elevation Trends
- 2-3C Groundwater Elevation Trends
- 2-3D Groundwater Elevation Trends
- 2-3E Groundwater Elevation Trends
- 2-4 Upper Surficial Aquifer Groundwater Contour Map, May 1995
- 2-5 Lower Surficial/Upper Castle Hayne Aquifer Groundwater Contour Map
- 2-6 Castle Hayne Aquifer Groundwater Contour Map
- 2-7 Potable Water supply Wells within a One-Mile Radius
- 2-8 Biohabitat Map

- 3-1 Soil Sampling Locations
- 3-2 Monitoring Well Locations
- 3-3 Typical Shallow Type II Groundwater Monitoring Well Construction Diagram
- 3-4 Typical Intermediate Type II Groundwater Monitoring Well Construction Diagram
- 3-5 Typical Deep Type III Groundwater Monitoring Well Construction Diagram

- 4-1 Organic Compounds in Surface Soil
- 4-2 Organic Compounds in Subsurface Soil
- 4-3 Selected TAL Metals in Surface Soil
- 4-4 Selected TAL Metals in Subsurface Soil
- 4-5 Organic Compounds in Groundwater
- 4-6 TAL Metals in Groundwater Above Screening Standards

- 6-1 Flowchart of Potential Exposure Pathways and Receptors
- 6-2 Cumulative Probability Percent of Blood Lead Levels - Site 86 Groundwater Exposure
- 6-3 Probability Distribution of Blood Lead Levels -Site 86 Groundwater Exposure

- 7-1 Conceptual Exposure Model for Ecological Receptors

LIST OF ACRONYMS AND ABBREVIATIONS

AET	Apparent Effects Threshold
AQUIRE	Aquatic Information Retrieval Database
ARAR	Applicable or Relevant and Appropriate Requirement
AST	Above Ground Storage Tank
ASTM	American Society for Testing and Materials
ATSDR	Agency for Toxic Substances and Disease Registry
AWQC	Ambient Water Quality Criteria
BaB	Baymeade
Baker	Baker Environmental, Incorporated
Bb	Beef Biotransfer Factor
BCF	Bioconcentration Factor
BEHP	Bis(2-ethylhexyl)phthalate
bgs	Below Ground Surface
BI	Biotic Index
Br	Plant Biotransfer Factor (fruit)
BRA	Baseline Human Health Risk Assessment
BTEX	Benzene, Toluene, Ethylbenzene, and Xylene
Bv	Plant Biotransfer Factor (leaf)
°C	Degrees Celsius
Carc.	Carcinogenic Effects
CDI	Chronic Daily Intake
CERCLA	Comprehensive Environmental Response, Compensation and Liability Act
CLEJ	Camp Lejeune
CLP	Contract Laboratory Program
COC	Contaminant of Concern
COPC	Contaminant of Potential Concern
CRAVE	Carcinogen Risk Assessment Verification Endeavor
CRDL	Contract Required Detection Limit
CRQL	Contract Required Quantitation Limit
CSF	Carcinogenic Slope Factor
DC	Direct Current
DEM	Division of Environmental Management
DO	Dissolved Oxygen
DOD	Department of the Defense
DoN	Department of the Navy
DQO	Data Quality Objective
EDB	Ethyl Dibromide
EMD	Environmental Management Division (Camp Lejeune)
EPIC	Environmental Photographic Interpretation Center
ER-L	Effects Range - Low
ER-M	Effects Range - Median
ERA	Ecological Risk Assessment
ESE	Environmental Science and Engineering

LIST OF ACRONYMS AND ABBREVIATIONS
(Continued)

°F	Degrees Fahrenheit
FFA	Federal Facilities Agreement
FID	Flame Ionization Detector
ft	Feet
FWS	Fish and Wildlife Service
gpm	Gallons per Minute
GW	Groundwater Well
H'	Species Diversity (Shannon-Wiener)
H	Species Diversity (Brillouins')
HA	Health Advisories
HEAST	Health Effects Assessment Summary Tables
HHAG	Human Health Assessment Group
HI	Hazard Index
HPIA	Hadnot Point Industrial Area
HQ	Hazard Quotient
IAS	Initial Assessment Study
ICR	Estimated Incremental Lifetime Cancer Risk
ID	Internal Diameter
IDW	Investigation Derived Waste
IRIS	Integrated Risk Information System
IRP	Installation Restoration Program
K_{oc}	Organic Carbon Partition Coefficient
K_{ow}	Octanol Water Partition Coefficient
LANTDIV	Naval Facilities Engineering Command, Atlantic Division
LOAEL	Lowest-Observed-Adverse-Effect-Level
MAG	Marine Air Groups
MBI	Macroinvertebrate Biotic Index
MCAS	Marine Corps Air Station
MCB	Marine Corps Base
MCL	Maximum Contaminant Level
MEK	Methyl Ethyl Ketone
MF	Modifying Factor
mg/L	Milligrams per Liter
mg/kg	Milligrams per Kilogram
MI	Mobility Index
MIBK	Methyl Isobutyl Ketone
MS/MSD	Matrix Spike and Matrix Spike Duplicate
msl	Mean Sea Level

LIST OF ACRONYMS AND ABBREVIATIONS
(Continued)

NC DEHNR	North Carolina Department of Environment, Health, and Natural Resources
NCP	National Contingency Plan
NCWQS	North Carolina Water Quality Standards
ND	Nondetect
NEESA	Naval Energy and Environmental Support Activity
NEHC	Navy Environmental Health Center
NFESC	Naval Facilities Engineering Service Center
NOAA	National Oceanic and Atmospheric Administration
NOAEL	No-Observed-Adverse-Effect-Level
NOEL	No-Observed-Effect Level
Noncarc.	Noncarcinogenic Effects
NPL	National Priorities List
NWI	National Wetlands Inventory
O&G	Oil and Grease
ORNL	Oak Ridge National Laboratory
OSWER	Office of Solid Waste and Emergency Response
OU	Operable Unit
PAH	Polynuclear Aromatic Hydrocarbon
PCB	Polychlorinated Biphenyl
PID	Photoionization Detector
ppb	Parts per Billion
ppm	Parts per Million
PVC	Polyvinyl Chloride
QA/QC	Quality Assurance/Quality Control
QI	Quotient Index
R	Retardation Factor
RA	Risk Assessment
RBC	Region III Risk-Based Concentration
RCRA	Resource Conservation and Recovery Act
RfD	Reference Dose
RI/FS	Remedial Investigation/Feasibility Study
RI	Remedial Investigation
RME	Reasonable Maximum Exposure
ROD	Record of Decision
S	Solubility
SA	Site Assessment
SAP	Sampling and Analysis Plan
SCS	Soil Conservation Service
SD	Sediment
SI	Suite Investigation
Sj	Jaccard Coefficient

LIST OF ACRONYMS AND ABBREVIATIONS
(Continued)

SM-SP	Fine Sand and Loamy Fine Sand
SMCL	Secondary Maximum Contaminant Level
SOP	Standard Operating Procedure
SQC	Sediment Quality Criteria
S _s	Sørensen Index
SSL	Sediment Screening Level
SSV	Sediment Screening Value
SSSV	Surface Soil Screening Value
STP	Sewage Treatment Plant
SU	Standard Unit
SVOC	Semivolatile Organic Compound
SW	Surface Water
SWSV	Surface Water Screening Value
TAL	Target Analyte List
TBC	To Be Considered
TCE	Trichloroethylene
TCL	Target Compound List
TCLP	Toxicity Characteristic Leaching Procedure
TDS	Total Dissolved Solids
TIC	Tentatively Identified Compound
TOC	Total Organic Carbon
TOC	Top-of-Casing
TPH	Total Petroleum Hydrocarbon
TRV	Terrestrial Reference Value
TSS	Total Suspended Solids
µg/L	Micrograms per Liter
µg/g	Micrograms per Gram
µg/kg	Micrograms per Kilogram
UBK	Uptake/Biokinetics
UCL	Upper Confidence Limit
UF	Uncertainty Factor
USCS	Unified Soil Classification System
USEPA	United States Environmental Protection Agency
USGS	United States Geological Survey
UST	Underground Storage Tank
VOC	Volatile Organic Compound
VP	Vapor Pressure
WAR	Water and Air Research, Incorporated
WOE	Weight-of-Evidence
WQS	Water Quality Standards
WQSV	Water Quality Screening Values

EXECUTIVE SUMMARY

INTRODUCTION

The purpose of an RI is to evaluate the nature and extent of the threat to public health and the environment caused by the release or threatened release of hazardous substances, pollutants, or contaminants. This RI investigation was conducted through the sampling of several environmental media (soil, groundwater, surface water, sediment, and fish tissue) at Operable Unit (OU) No. 6, evaluating the resultant analytical data, and performing a human health risk assessment (RA) and ecological RA. This RI report contains the results of all field investigations, the human health RA, and the ecological RA. Furthermore, the RI report provides information to support the FS and Record of Decision (ROD) document.

Operable Unit Description

OU No. 6 is located within the northwest portion of the facility, to the south and east of Camp Geiger Development Area. Site 36 is referred to as the "Camp Geiger Area Dump," Site 43 is the "Agan Street Dump," Site 44 is known as the "Jones Street Dump," Site 54 is the "Crash Crew Fire Training Burn Pit," and Site 86 is known as the "Tank Area AS419-AS421 at MCAS."

Site Description and History

Site 86 is located on the southwest corner of the Foster and Campbell Street intersection, within the operations area of MCAS New River. The site is comprised of a lawn area surrounded by buildings, asphalt roads, and parking lots. Concrete pylons, upon which electric and steam overhead utilities are mounted, line the northern, western, and southern boundaries of the site. Campbell Street borders the site to the north and Foster Street lies adjacent to the east. Immediately to the south of the study area is Building AS-502, the MCAS fire station. The entrance road to the fire station borders the study area to the west.

The ground surface at Site 86 gently slopes to the south, toward a drainage ditch and culvert. Storm water drains that are located along Campbell Street receive runoff from only the northernmost portion of the study area. Stormwater from Site 86 eventually discharges into the New River, which lies approximately three quarters of a mile to the east.

Site 86 served as a storage area for petroleum products from 1954 to 1988. In 1954, three 25,000-gallon above ground storage tanks (ASTs) were installed within an earthen berm. Additionally, a small pump house was constructed to transfer fuel oil to and from the ASTs. The three tanks were reportedly used for No.6 fuel oil storage until 1979. From 1979 to 1988 the tanks were then used for temporary storage of waste oil (O'Brien & Gere, 1992). The three tanks were emptied in 1988 and are believed to have been removed in 1992. Today, the former location of the tanks is grass-covered and only a very slight depression remains.

GEOLOGY

A similar depositional sequence was encountered in borings throughout Site 86. The sequence generally matches the stratigraphic sequence discussed in the U.S. Geological Survey report prepared for MCB Camp Lejeune (Cardinell, et al., 1993). The uppermost formation at Site 86 is called the undifferentiated formation. The Belgrade Formation is absent at Site 86. Thus, the River

Bend Formation lies immediately below the undifferentiated formation. The following discussion of subsurface lithologies includes Site 86 as well as the surrounding area.

The soils at Site 86 have been disturbed through construction activities. Additionally, until recently three aboveground storage tanks (ASTs) were located at Site 86. It is evident through observations in some soil borings that the soils have been reworked. Non-native material, including rock and coal fragments, and concrete was observed in some shallow soil borings, typically to a depth of 3 feet. Non-native material was observed to a depth of 9.5 feet and 7 feet, respectively in borings 86-ASTSB05 and 86-AST-SB06.

The uppermost formation at Site 86, the undifferentiated formation, consists of unconsolidated sediments of Holocene and Pleistocene ages. This formation typically extends to a depth between 25 to 35 feet below ground surface (bgs). A predominantly clay layer occurs at the surface south of the site and on the western portion of the site. A predominantly fine to medium sand layer occurs at the surface east of the site. Both the sand and clay layers are typically 5 to 15 feet thick, and tend to be thickest under Site 86. The clay layer tends to be soft to stiff, and the sand loose to medium dense. Below the sand and clay layers, is a predominantly fine to coarse sand layer. A fine sand replaces the medium sand west of the site. This fine to medium sand layer is typically 15 to 30 feet thick, and thickest south and southwest of the site. This sand layer tends to be loose to medium dense. A silty fine sand lies immediately below the fine to medium sand layer. This silty fine sand layer is typically 5 to 10 feet thick, and is very loose to loose. This layer is absent southwest of the site and in the Campbell Street area.

The River Bend Formation, which constitutes the uppermost unit of the Castle Hayne aquifer at the site, consists of several units of the Oligocene age. This formation lies 25 to 35 feet bgs at Site 86. The uppermost unit is a fossiliferous limestone 5 to 25 feet thick. The limestone consists of cemented and partially cemented shell fragments in a calcareous matrix of fine sand, silt, or clay. This limestone is typically medium dense to dense. A localized fine sand deposit of limited extent approximately 8 foot thick is present within the fossiliferous limestone formation and is typically medium dense to dense. A silty fine sand layer lies below the fossiliferous limestone. The silty fine sand layer is 35 to 45 feet thick and medium dense to very dense. A very stiff clay or silty clay layer was encountered below the silty fine sand, at a depth between 95 and 105 feet bgs.

HYDROGEOLOGY

There are several aquifers beneath Site 86 and vicinity. The uppermost two aquifers were investigated in this study; the surficial and Castle Hayne. The surficial aquifer, which is under unconfined conditions (i.e., water table aquifer), occurs within the sediments of the undifferentiated formation typically within 10 feet of the surface. The upper portion of the Castle Hayne aquifer occurs within the sediments of the River Bend Formation. The Belgrade Formation (Castle Hayne confining unit) is absent in the vicinity of the site. Sediments were observed to be saturated from the water table through boring completion. Thus, the surficial and Castle Hayne can be considered as one aquifer. According to Cardinell, the Castle Hayne aquifer is approximately 200 feet thick in the vicinity of Camp Geiger and the Air Station. Combining the Castle Hayne thickness with the surficial aquifer thickness, the total saturated thickness is then approximately 220 feet.

The average surficial aquifer hydraulic conductivity value calculated during this study is an order of magnitude lower than the value presented by Cardinell. The average hydraulic conductivity value

at Site 86, based on RI slug tests is 2.8 feet/day (shallow wells), compared to 50 feet/day presented in Cardinell. The Cardinell value was estimated based on grain size; a general composition of fine sand, mixed with some silt and clay. The average hydraulic conductivity and transmissivity for the Castle Hayne (intermediate and deep) at Site 86 is 3.4 feet/day and 757 feet²/day, respectively. Cardinell reported hydraulic conductivities and transmissivities from several studies. Hydraulic conductivities ranged from 14 to 91 feet/day, and transmissivities range from 820 to 26,000 feet²/day. The RI results at Site 86 tend to less than the range from other sites throughout MCB Camp Lejeune. The differences may be attributable to several factors. Most of the Site 86 wells are screened in less conductive sitty fine sand layers of the Castle Hayne aquifer, while supply wells would likely be screened in more productive zones. Different test methodologies would produce different results (e.g., slug test verses pumping tests). Additionally, the Cardinell data encompassed several sites over a larger area than Site 86.

For the sufficial aquifer, calculated groundwater flow velocities varied by two orders of magnitude, ranging from 0.003 feet/day to 0.13 feet/day. For the Castle Hayne aquifer, calculated groundwater flow velocities also varied by two orders of magnitude, ranging from 0.002 feet/day to 0.11 feet/day. The varying velocities are attributable to the varying hydraulic conductivities.

Local and regional groundwater flow patterns were observed at Site 86. Local flow; flow within the sufficial aquifer is toward Stick Creek, with an average velocity of 0.05 feet/day. Surficial aquifer groundwater likely discharges to Stick Creek, based on groundwater flow direction and elevation relative to the creek. Regional flow, for within the lower surficial and upper Castle Hayne aquifers flows toward the New River with an average velocity of 0.03 feet/day. It is likely that groundwater in the Castle Hayne aquifer discharges to the New River. This observation is supported by groundwater elevation data compiled and mapped by Cardinell which indicates that groundwater in the Castle Hayne aquifer flows toward, and discharges to the New River and its major tributaries.

There appears to be a hydraulic connection between the surficial and Castle Hayne aquifers. The Castle Hayne confining unit was observed to be absent in the vicinity of Site 86. Additionally, the well cluster groundwater elevation data exhibit a downward flow component that is typical for groundwater recharge areas. This is consistent with Cardinell, who indicates that groundwater recharge occurs in interstream areas, like the Site 86 area.

REMEDIAL INVESTIGATIONS ACTIVITIES

The field investigation program at OU No.6, Site 86, was initiated to detect and characterize potential impacts to human health and the environment resulting from past waste management activities. This section discusses the site-specific RI field investigation activities that were conducted to fulfill the objective. The RI field investigation of OU No.6 commenced on February 20, 1995 and continued through May 10, 1995. The RI field program at Site 86 consisted of a site survey; a soil investigation, which included drilling and sampling; a groundwater investigation, which included monitoring well installation, sampling, and aquifer testing; and a habitat evaluation. The following sections detail the various investigation activities carried out during the RI.

A total of 20 borings were completed at Site 86 to assess the suspected impact of former operations; four of those borings were utilized for the installation of monitoring wells. Twelve of the 20 borings were advanced from within and immediately adjacent to the former storage tank area, as stipulated in the Final RI/FS Work Plan for OU No.6 (Baker, 1994). Soil samples were also obtained from four monitoring well test borings collected from within and surrounding the study area. The remaining

four soil borings were collected from two separate locations where ancillary piping and equipment associated with the former storage tanks were located.

The analytical program employed during the soil investigation at Site 86 focused on suspected contaminants of concern, as indicated by information regarding temporary storage operations and investigation results. Samples from 7 of the 20 soil boring locations were analyzed for full TCL organics (i.e., volatiles, semivolatiles, pesticides, and PCBs), TPH, and TAL metals. Full TCL organics and TAL metals analyses were requested for samples from 9 of the 20 boring locations. Samples from the remaining four locations were submitted for TCL volatile and semivolatile analyses only.

Groundwater samples were collected from seven existing shallow wells, two newly installed shallow wells, seven existing intermediate wells, nine newly installed intermediate wells, and five newly installed deep wells at Site 86. Groundwater samples were collected at Site 86 in March, April, May, and October of 1995.

Groundwater samples from seven existing shallow wells, seven existing intermediate wells, two newly installed shallow wells, nine newly installed intermediate wells, and five newly installed deep wells were submitted for laboratory analysis from Site 86. Samples from each of the 14 existing wells (86-GW01 through 86-GW141W), four of the newly installed intermediate wells (86-GW151W, 86-GW161W, 86-GW171W, and 86-GW201W), and the 5 newly installed deep wells (86-GW1 SDW, 86-GW1 6DW, 86-GW1 7DW, 86-GW1 8DW, and 86-GW1 9DW) were analyzed for full TCL volatiles, TCL semivolatiles, TAL total metals, total suspended solids (TSS), and total dissolved solids (TDS). Groundwater samples obtained from three intermediate wells (86-GW21 IW, 86-GW221W, and 86-GW231W) to the south and southeast of the study area were analyzed for TCL volatiles, TAL metals, TSS, and TDS. In addition, a limited number of groundwater samples were also analyzed for TCL pesticides, TCL PCBs, and TAL dissolved metals. The groundwater samples were analyzed using Contract Laboratory Program (CLP) protocols and Level IV data quality.

EXTENT OF CONTAMINATION

This section presents a summary of analytical findings from field sampling activities conducted at Site 86. Table ES-1 provides a summary of site contamination for Site 86.

Soils

Positive detections of volatile and semivolatile organic compounds were detected in both surface and subsurface soil samples obtained from Site 86. The majority of SVOCs detected in soil samples were PAH compounds. Several SVOCs were detected at concentrations greater than 500 µg/kg. The maximum VOC concentration was 25 µg/kg of toluene.

Based upon the results of analyses from 11 surface and 16 subsurface soil samples, the pesticides dieldrin, 4,4'-DDE, 4,4'-DDD and 4,4'-DDT appear to be scattered throughout the study area. The pesticide 4,4'-DDE was the most prevalent, with 15 positive detections ranging from 1.5 to 38 µg/kg. The highest pesticide concentration was that of dieldrin at 44 µg/kg. Pesticides were detected in soil samples from Site 86 at low concentrations and without a discernible pattern of dispersal.

TABLE ES-1

**SUMMARY OF SITE CONTAMINATION
SITE 86, ABOVE GROUND STORAGE TANK AREA
REMEDIAL INVESTIGATION, CTO-0303
MCAS, NEW RIVER, NORTH CAROLINA**

Media	Fraction	Detected Contaminants	Comparison Criteria		Site Contamination				
			Standard	Base Background	Min.	Max.	Max. Location	Detection Frequency	Distribution
Surface Soil	Volatiles	Toluene	NA	NA	25	25	86-GW18DW	1/18	former tank area
		Xylene (total)	NA	NA	5	5	AST-SB02	1/18	former tank area
	Semivolatiles	Naphthalene (PAH)	NA	NA	85	85	AST-SB11	1/18	former tank area
		2-Methylnaphthalene	NA	NA	80	80	AST-SB11	1/18	former tank area
		Acenaphthene (PAH)	NA	NA	50	580	AST-SB11	4/18	scattered
		Dibenzofuran	NA	NA	220	220	AST-SB11	1/18	former tank area
		Fluorene (PAH)	NA	NA	43	440	AST-SB11	3/18	scattered
		Phenanthrene (PAH)	NA	NA	64	2,700	AST-SB11	8/18	scattered
		Anthracene (PAH)	NA	NA	43	790	AST-SB11	5/18	scattered
		Carbazole	NA	NA	39	480	AST-SB11	5/18	scattered
		Fluoranthene (PAH)	NA	NA	39	3,500	AST-SB11	9/18	scattered
		Pyrene (PAH)	NA	NA	110	3,100	AST-SB11	10/18	scattered
		Butyl benzyl phthalate	NA	NA	49	380	AST-SB03	4/18	former tank area
		B(a)anthracene (PAH)	NA	NA	70	2,100	AST-SB11	10/18	scattered
		Chrysene (PAH)	NA	NA	86	2,100	AST-SB11	9/18	scattered
		B(b)fluoranthene (PAH)	NA	NA	110	2,300	AST-SB11	8/18	scattered
		B(k)fluoranthene (PAH)	NA	NA	57	950	AST-SB11	8/18	scattered
		Benzo(a)pyrene (PAH)	NA	NA	48	1,800	AST-SB11	10/18	scattered
		I(1,2,3-cd)pyrene (PAH)	NA	NA	67	1,100	AST-SB11	7/18	scattered
		D(a,h)anthracene (PAH)	NA	NA	37	290	AST-SB11	4/18	former tank area
B(g,h,i)perylene (PAH)	NA	NA	57	590	86-GW19DW	7/18	scattered		

TABLE ES-1 (Continued)

SUMMARY OF SITE CONTAMINATION
 SITE 86, ABOVE GROUND STORAGE TANK AREA
 REMEDIAL INVESTIGATION, CTO-0303
 MCAS, NEW RIVER, NORTH CAROLINA

Media	Fraction	Detected Contaminants	Comparison Criteria		Site Contamination				
			Standard	Base Background	Min.	Max.	Max. Location	Detection Frequency	Distribution
Surface Soil (Continued)	Pesticides	Aldrin	NA	NA	2	2	86-GW18DW	1/11	former tank area
		Heptachlor epoxide	NA	NA	5.2	5.2	86-GW19DW	1/11	southeast
		Dieldrin	NA	NA	4.8	44	AST-SB01	10/11	widely scattered, prevalent
		4-4'-DDE	NA	NA	4.9	38	86-GW19DW	11/11	widely scattered, prevalent
		4-4'-DDD	NA	NA	5.2	9.6	AST-SB08	5/11	scattered
		4-4'-DDT	NA	NA	4.3	27	AST-SB08	10/11	widely scattered, prevalent
	PCBs	ND	NA	NA				0/11	
	Metals (1)	Arsenic	NA	1.3	0.5	1.8	AST-SB08	9/11	2 exceed BB, former tank area
		Cadmium	NA	0.7	0.5	1.1	86-GW18DW	5/11	2 exceed BB, former tank area
		Chromium	NA	6.7	5.1	10.1	AST-SB08	11/11	8 exceed BB, former tank area
		Copper	NA	7.2	1.1	53.4	86-GW18DW	10/11	3 exceed BB, former tank area
		Lead	NA	23.7	12.4	43.1	AST-SB03	11/11	5 exceed BB, former tank area
		Mercury	NA	0.1	0.2	0.2	86-GW19DW	1/11	1 exceeds BB, southeast
		Nickel	NA	3.4	1.3	22.3	86-GW19DW	8/11	7 exceed BB, former tank area
Zinc		NA	13.9	5.4	39.9	86-GW18DW	11/11	6 exceed BB, former tank area	
Subsurface Soil	Volatiles	Carbon Disulfide	NA	NA	3	3	WA-SB01	1/23	south of former tank area
		Toluene	NA	NA	250	250	86-GW18DW	1/23	former tank area
		Xylene (total)	NA	NA	5	5	AST-SB07	2/23	former tank area
	Semivolatiles	Fluoranthene (PAH)	NA	NA	62	62	86-GW19DW	1/23	southeast
		Pyrene (PAH)	NA	NA	57	57	86-GW19DW	1/23	southeast
		Butylbenzylphtalate	NA	NA	73	300	AST-SB11	4/23	former tank area
		Chrysene (PAH)	NA	NA	42	140	AST-SB04	2/23	former tank area
		B(b)fluoranthene (PAH)	NA	NA	43	43	86-GW19DW	1/23	southeast

TABLE ES-1 (Continued)

SUMMARY OF SITE CONTAMINATION
 SITE 86, ABOVE GROUND STORAGE TANK AREA
 REMEDIAL INVESTIGATION, CTO-0303
 MCAS, NEW RIVER, NORTH CAROLINA

Media	Fraction	Detected Contaminants	Comparison Criteria		Site Contamination				
			Standard	Base Background	Min.	Max.	Max. Location	Detection Frequency	Distribution
Subsurface Soil (Continued)	Pesticides	4,4'-DDE	NA	NA	1.5	20	AST-SB04	5/16	scattered
		4,4'-DDD	NA	NA	3.2	36	86-GW17IW	5/16	scattered
		4,4'-DDT	NA	NA	1.5	1.5	AST-SB04	1/16	former tank area
	PCBs	ND	NA	NA				0/16	
	Metals (1)	Antimony	NA	6.4	2.2	2.2	86-GW17IW	1/12	does not exceed BB
		Arsenic	NA	1.9	0.3	2.4	AST-SB07	13/16	2 exceed BB, former tank area
		Chromium	NA	12.6	2.4	34.4	AST-SB06	16/16	9 exceed BB, scattered
		Copper	NA	2.4	0.6	7.1	AST-SB04	14/16	5 exceed BB, former tank area
		Lead	NA	8.3	3	16.6	AST-SB06	16/16	12 exceed BB, scattered
		Nickel	NA	3.7	1	28.2	AST-SB05	12/16	4 exceed BB, former tank area
Zinc		NA	6.7	1.3	7.9	AST-SB06	15/16	2 exceed BB, former tank area	
Groundwater	Volatiles	1,1-Dichloroethane	NCWQS - 700	NA	10	14	86-GW10IW	2/41	do not exceed standard
		1,2-Dichloroethene (total)	MCL - 70	NA	3	140	86-GW15IW	14/41	2 exceed standard, southeast
		Trichloroethene	NCWQS - 2.8	NA	2	400	86-GW20IW	13/41	12 exceed standard, south and central
		Benzene	NCWQS - 1	NA	2	8	86-GW15IW	7/41	7 exceed standard, south and central
		Tetrachloroethene	NCWQS - 0.7	NA	1	77	86-GW10IW	4/41	4 exceed standard, south and central
	Semivolatiles	Naphthalene (PAH)	NCWQS - 21	NA	6	6	86-GW10IW	1/23	does not exceed standard, southeast
		Dibenzofuran	NA	NA	1	1	86-GW07	1/23	north of former tank area
		Fluorene (PAH)	NCWQS - 280	NA	2	2	86-GW07	1/23	does not exceed standard, north
		Di-n-butylphthalate	NCWQS - 700	NA	23	23	86-GW17IW	1/23	does not exceed standard, west
	Pesticides	ND	NA	NA				0/5	
PCBs	ND	NA	NA				0/5		

ES-7

TABLE ES-1 (Continued)

SUMMARY OF SITE CONTAMINATION
 SITE 86, ABOVE GROUND STORAGE TANK AREA
 REMEDIAL INVESTIGATION, CTO-0303
 MCAS, NEW RIVER, NORTH CAROLINA

Media	Fraction	Detected Contaminants	Comparison Criteria		Site Contamination				
			Standard	Base Background	Min.	Max.	Max. Location	Detection Frequency	Distribution
Groundwater (Continued)	Total Metals	Antimony	MCL - 6	NA	23.6	23.6	86-GW16DW	1/26	1 exceeds standard, east
		Iron	NCWQS - 300	NA	5.1	68,300	86-GW07	23/26	19 exceed standard, scattered
		Lead	NCWQS - 15	NA	28.3	28.3	86-GW06IW	1/26	1 exceeds standard, tank area
		Manganese	NCWQS - 50	NA	3.8	416	86-GW17IW	22/26	15 exceed standard, scattered

Notes:

- Concentrations are presented in µg/L for liquid and µg/Kg for solids (ppb), metal concentrations for soils and sediments are presented in mg/Kg (ppm).
- (1) Metals in both surface and subsurface soils were compared to twice the average base background positive concentrations for priority pollutant metals only (i.e., antimony, arsenic, beryllium, cadmium, chromium, copper, lead, mercury, nickel, selenium, silver, thallium, zinc).

ES-8

- ARAR - Applicable or Relevant and Appropriate Requirements
- BB - Base background, value equals two times average value for soil (refer to Appendix O)
- NA - Not applicable
- NCWQS - North Carolina Water Quality Standard
- ND - Not detected
- NOAA - National Oceanic and Atmospheric Administration
- MCL - Federal Maximum Contaminant Level
- PAH - Polynuclear aromatic hydrocarbon

Inorganic analytes were detected in both surface and subsurface soil samples at concentrations above twice the average applicable base-specific background levels. Chromium and lead were detected at concentrations above twice their average base-specific background levels in 17 of the 27 soil samples. Other TAL Metals such as arsenic, cadmium, copper, mercury, nickel, and zinc were detected fewer than 10 times above twice their average base-specific background levels. In general, slightly higher concentrations of inorganic analytes were detected in soil samples obtained from within the former AST area.

Groundwater

Positive detections of organic compounds were limited to samples obtained from the surficial aquifer. As provided in Table ES-1, seven positive detections of benzene and eight positive detections of trichloroethene exceeded their applicable screening standards of 1 and 5 µg/L. In addition, two detections of total 1,2-dichloroethene and four detections tetrachloroethene were detected at concentrations in excess of their 70 and 0.7 µg/L screening standards.

Inorganics were the most prevalent and widely distributed constituents among groundwater samples obtained at Site 86. Iron and manganese were the most prevalent inorganic analytes detected at concentrations that exceeded state standards in 19 and 15 groundwater samples, respectively. Antimony and lead were each detected once in excess of state or federal screening standards. No other inorganics were detected above applicable screening standards.

HUMAN HEALTH RISK ASSESSMENT

At Site 86, exposure to surface soil was assessed for the current receptors. Soil and groundwater exposure were evaluated for the future receptors.

In the current case, the following receptors were assessed: military personnel and adult and child trespassers. Receptor exposure to surface soil was evaluated. The calculated risk values for these receptors were within acceptable risk levels.

In the future case, child and adult residents were assessed for potential exposure to groundwater and subsurface soil. A construction worker was evaluated for surface and subsurface soil exposure. The potential risks calculated for the construction worker were within acceptable risk levels.

The total noncarcinogenic risk and carcinogenic risk for the adult resident exceeded acceptable risk levels of one for noncarcinogenic effects and 1×10^{-4} for carcinogenic effects. These values were 8.1 and 1.3×10^{-4} , respectively. The total noncarcinogenic risk for the child resident, 20, was also greater than the acceptable risk level of one. In both cases, groundwater ingestion was the main exposure route contributing to these unacceptable risks. In terms of lead effects, exposure to the maximum concentration of lead in the groundwater for a child receptor indicates the potential for adverse health effects. The maximum levels of iron and lead and the lognormal 95% UCL values of arsenic and antimony in groundwater contributed to these risks.

As stated previously, groundwater is not currently used potably at the site. Future residential development of the site is unlikely. Based on this information, the future groundwater exposure scenario evaluated in this BRA, although highly protective of human health, is unlikely to occur.

Although antimony was found infrequently in groundwater, it was detected at levels greater than both risk-based screening levels and federal and state criteria. Arsenic was detected frequently in the site groundwater at levels greater than the risk-based screening level. However, these same levels were below both federal and state safe drinking water criteria (i.e., MCLs). Lead was only found once in the groundwater, but at a level that exceeded the federal drinking water action level.

As explained in Section 4.0 of this report, groundwater in the MCB Camp Lejeune area is naturally rich in iron. There is no record of any historical use of iron at Site 86. Consequently, it is assumed that iron is a naturally-occurring inorganic in groundwater, and its presence is not attributable to site operations.

Iron is an essential nutrient. The toxicity values associated with exposure to this metal are based on provisional studies, which have not been verified by USEPA. In fact, if iron were removed from the evaluation of risk from groundwater ingestion, the noncarcinogenic risk for the child would decrease from 1.8 to 0.3 and, for the adult, from 7.8 to 1.6. As a result, the potential human health risk from exposure to these metals in groundwater may be a conservative and unrealistic estimate.

ECOLOGICAL RISK ASSESSMENT

Terrestrial Receptors

As presented earlier in the ERA, the assessment endpoints for the terrestrial receptors are the potential reduction of a receptor population or subpopulation that is attributable to contaminants from Site 86. This section evaluates this assessment endpoint using the measurement endpoints.

The first measurement endpoint is to determine if there is an exceedance of contaminant-specific soil effect concentrations (i.e., SSSVs). Several COPCs were detected in the surface soils at concentrations exceeding the SSSVs. Therefore, there is a potential for adverse impacts to terrestrial flora, invertebrates, and/or microorganisms from these contaminants. It should be noted that the only habitat at Site 86 is mowed grass, with the remaining area consisting of buildings and asphalt. Therefore, ecological receptors have a low potential for becoming exposed to contaminants in the surface soil due to the availability of natural habitat.

The second measurement endpoint is to determine if the terrestrial CDI exceeds the TRVs. The cottontail rabbit is the only terrestrial species with estimated CDI values that exceeded the TRV values. The QI of rabbit (2.2) just slightly exceeded "1", and therefore the COPCs at Site 86 are not expected to impact terrestrial receptors (vertebrates).

Overall, some potential impacts to soil invertebrates and plants may occur as a result of site-related contaminants. As presented in more detail in the Uncertainty Analysis section of this ERA, there is much uncertainty in the SSSVs. In addition, Site 86 is an industrial area that consists primarily of mowed grass and asphalt. Therefore, an ecologically diverse population of terrestrial receptors is not expected to inhabit the site, and should not be impacted from site-related contaminants.

1.0 INTRODUCTION

Marine Corps Base (MCB), Camp Lejeune was placed on the Comprehensive Environmental Response, Compensation, and Liability Act (CERCLA) National Priorities List (NPL) on October 4, 1989 (54 Federal Register 41015, October 4, 1989). Subsequent to this listing, the United States Environmental Protection Agency (USEPA) Region IV; the North Carolina Department of Environment, Health and Natural Resources (NC DEHNR); and the United States Department of the Navy (DoN) entered into a Federal Facilities Agreement (FFA) for MCB, Camp Lejeune. The primary purpose of the FFA is to ensure that environmental impacts associated with past and present activities at MCB, Camp Lejeune are thoroughly investigated and appropriate CERCLA response/Resource Conservation and Recovery Act (RCRA) corrective action alternatives are developed and implemented, as necessary, to protect public health, welfare, and the environment (FFA, 1989).

The Fiscal Year 1996 Site Management Plan for MCB, Camp Lejeune, the primary document referenced in the FFA, identifies 33 sites that require Remedial Investigation/Feasibility Study (RI/FS) activities. These 33 sites have been divided into 16 operable units to simplify RI/FS activities. An RI was conducted at Operable Unit (OU) No. 6, Sites 36, 43, 44, 54, and 86, during February through May of 1995. This report describes the RI conducted at Site 86, the Tank Area AS419-AS421 at Marine Corps Air Station (MCAS), New River. For the purpose of this report, Site 86 will be referred to as the Above Ground Storage Tank Area. Four additional reports have been prepared that address each of the other OU No. 6 sites. Figure 1-1 depicts the location of the five sites that comprise OU No. 6. [Note that all tables and figures are presented in the back of each section.]

The purpose of an RI is to evaluate the nature and extent of the threat to public health and the environment caused by the release or threatened release of hazardous substances, pollutants, or contaminants. This RI investigation was conducted through the sampling of several environmental media (soil, groundwater, surface water, sediment, and fish tissue) at OU No. 6, evaluating the resultant analytical data, and performing a human health risk assessment (RA) and ecological RA. This RI report contains the results of all field investigations, the human health RA, and the ecological RA. Furthermore, the RI report provides information to support the FS and Record of Decision (ROD) documents.

This RI Report has been prepared by Baker Environmental, Inc. (Baker) and submitted to the USEPA Region IV; the NC DEHNR; MCB, Camp Lejeune Environmental Management Department (EMD); the Navy Environmental Health Center (NEHC); the Agency for Toxic Substances and Disease Registry (ASTDR); and to the Naval Facilities Engineering Command, Atlantic Division (LANTDIV) for their review.

The following subsections describe the arrangement of OU No. 6 and the background and setting of both MCB, Camp Lejeune and Site 86. In addition, Section 1.1 provides an overview of the RI report's organization.

1.1 Report Organization

This RI Report is comprised of one text volume; appendices are provided in an additional volume. The following section headings are included within this text volume and provide site-specific investigation findings:

- Study Area Investigation - Section 2.0
- Site Physical Characteristics - Section 3.0
- Nature and Extent of Contamination - Section 4.0
- Contaminant Fate and Transport - Section 5.0
- Baseline Human Health Risk Assessment - Section 6.0
- Ecological Risk Assessment - Section 7.0
- Conclusions - Section 8.0

1.2 Background and Setting of MCB, Camp Lejeune

The following section summarizes existing background and setting information that pertains to MCB, Camp Lejeune. This section specifically addresses the location and setting of MCB, Camp Lejeune, its history, topography, geology, hydrogeology, climatology, ecology, land use, and demography.

1.2.1 Location and Setting

MCB, Camp Lejeune is located on the coastal plain of North Carolina in Onslow County. The facility encompasses approximately 234 square miles and is bisected by the New River. The New River flows in a southeasterly direction and forms a large estuary before entering the Atlantic Ocean. The southeastern border of MCB, Camp Lejeune is the Atlantic Ocean shoreline. The western and northeastern boundaries of the facility are U.S. Route 17 and State Route 24, respectively. The City of Jacksonville borders MCB, Camp Lejeune to the north (refer to Figure 1-1).

1.2.2 History

Construction of MCB, Camp Lejeune began in April 1941 at the Hadnot Point Industrial Area (HPIA), where major functions of the base are located today. The facility was designed to be the "World's Most Complete Amphibious Training Base." The MCB, Camp Lejeune complex consists of five geographical locations under the jurisdiction of the Base Command. These areas include Camp Geiger, Montford Point, Courthouse Bay, Mainside, and the Rifle Range Area. Site 36 is located within the Camp Geiger operations area. The remaining four sites that comprise OU No. 6, Sites 43, 44, 54, and 86, are located within the MCAS, New River operations area. Although MCAS, New River is under the jurisdiction of a separate command (i.e., MCAS, Cherry Point), environmental compliance issues and Installation Restoration Program (IRP) sites are the responsibility of MCB, Camp Lejeune EMD.

1.2.3 Operable Unit Description

Operable units are formed as an incremental step toward addressing individual site concerns. There are currently 33 IRP sites at MCB, Camp Lejeune, which have been grouped into 16 operable units. Due to the similar nature of suspected waste and their close proximity to one another, Sites 36, 43, 44, 54, and 86 were grouped together as OU No. 6. Figure 1-2 depicts the locations of all 16 operable units at MCB, Camp Lejeune.

OU No. 6 is located within the northwest portion of the facility, to the south and east of Camp Geiger Development Area. Site 36 is referred to as the "Camp Geiger Area Dump," Site 43 is the "Agan Street Dump," Site 44 is known as the "Jones Street Dump," Site 54 is the "Crash Crew Fire Training Burn Pit," and Site 86 is known as the "Above Ground Storage Tank Area."

1.2.4 Topography

The flat topography of MCB, Camp Lejeune is typical of seaward portions of the North Carolina coastal plain. Elevations on the base vary from sea level to 72 feet above mean sea level (msl); however, most of MCB, Camp Lejeune is between 20 and 40 feet above msl.

Drainage at MCB, Camp Lejeune is generally toward the New River, except in areas near the coast where flow is into the Intracoastal Waterway that lies between the mainland and barrier islands. In developed areas of the facility, natural drainage has been altered by asphalt cover, storm sewers, and drainage ditches. Approximately 70 percent of MCB, Camp Lejeune is comprised of broad, flat interstream areas with poor drainage (WAR, 1983).

1.2.5 Surface Water Hydrology

The dominant surface water feature at MCB, Camp Lejeune is the New River. It receives drainage from a majority of the base. The New River is short with a course of approximately 50 miles on the central Coastal Plain of North Carolina. Over most of its length, the New River is confined to a relatively narrow channel in Eocene and Oligocene limestones. South of Jacksonville, the river widens dramatically as it flows across less resistant sands, clays, and marls. At MCB, Camp Lejeune, the New River flows in a southerly direction into the Atlantic Ocean through the New River Inlet. Several small coastal creeks drain the area of MCB, Camp Lejeune not associated with the New River and its tributaries. These creeks flow into the Intracoastal Waterway, which is connected to the Atlantic Ocean by Bear Inlet, Brown's Inlet, and the New River Inlet. The New River, the Intracoastal Waterway, and the Atlantic Ocean converge at the New River Inlet.

Water quality criteria for surface waters in North Carolina have been published under Title 15 of the North Carolina Administrative Code. At MCB, Camp Lejeune, the New River falls into two classifications: SC (estuarine waters not suited for body-contact sports or commercial shellfishing); and SA (estuarine waters suited for commercial shellfishing). The SC classification applies to only three areas of the New River at MCB, Camp Lejeune; the rest of the New River at MCB, Camp Lejeune falls into the SA classification (ESE, 1990).

1.2.6 Geology

MCB, Camp Lejeune is located within the Atlantic Coastal Plain physiographic province. The sediments of this province consist primarily of sand, silt, and clay. Other sediments may be present, including shell beds and gravel. Sediments may be of marine or continental origin. These sediments are found in interfingering beds and lenses that gently dip and thicken to the southeast. Sediments of this type range in age from early Cretaceous to Quaternary time and overlie igneous and metamorphic rocks of pre-Cretaceous age. Table 1-1 presents a generalized stratigraphic column for the Atlantic Coastal Plain of North Carolina (Harned et al., 1989).

United States Geological Survey (USGS) studies at MCB, Camp Lejeune indicate that the base is underlain by sand, silt, clay, calcareous clay and partially cemented limestone. The combined thickness of these sediments beneath the base is approximately 1,500 feet.

1.2.7 Hydrogeology

The aquifers of primary interest are the surficial aquifer and the aquifer immediately below it, the Castle Hayne aquifer. Other aquifers that occur beneath the facility include the Beaufort, Peedee, Black Creek, and upper and lower Cape Fear aquifers. The following summary is a compilation of information which pertains to aquifer characteristics within the MCB, Camp Lejeune area. A generalized hydrogeologic cross-section illustrating the relationship between the aquifers in this area is presented in Figures 1-3 and 1-4.

The surficial aquifer consists of interfingering beds of sand, clay, sandy clay, and silt that contain some peat and shells. The thickness of the surficial aquifer ranges from 0 to 73 feet and averages nearly 25 feet over the MCB, Camp Lejeune area. It is generally thickest in the interstream divide areas and presumed absent where it is cut by the New River and its tributaries. The beds are thin and discontinuous, and have limited lateral continuity. This aquifer is not used for water supply at MCB, Camp Lejeune.

The general lithology of the surficial aquifer and the absence of any thick, continuous clay beds are indications of relatively high vertical conductivity within the aquifer. The estimated lateral hydraulic conductivity of the surficial aquifer in the MCB, Camp Lejeune area is 50 feet per day, and is based on a general composition of fine sand mixed with some silt and clay (Harned et al., 1989). However, data from a number of slug tests conducted by Baker at sites near OU No. 6 indicate much lower lateral hydraulic conductivity values. These values range from 7.2×10^{-4} feet per day to 6.4 feet per day. Table 1-2 presents a summary of hydraulic properties compiled during investigations at other sites located within the developed portion of MCAS, New River.

Between the surficial and the Castle Hayne aquifers lies the Castle Hayne confining unit. This unit consists of clay, silt, and sandy clay beds. In general, the Castle Hayne confining unit may be characterized as a group of less permeable beds at the top of the Castle Hayne aquifer that have been partly eroded or incised in places. The Castle Hayne confining unit is discontinuous, and has a thickness ranging from 0 to 26 feet, averaging about 9 feet where present. There is no discernable trend in the thickness of the confining unit seen in these or related investigations, nor is there any information in the USGS literature regarding any trend of the depth of the confining unit.

Previously recorded data indicate that vertical hydraulic conductivity of the confining unit ranged from 0.0014 to 0.41 feet per day (Cardinell et al., 1993). Data obtained from a pump test conducted by ESE indicated a vertical hydraulic conductivity for this unit ranging from 1.4×10^{-3} to 5.1×10^{-2} feet per day (ESE, 1988). Based on the moderate conductivity values and the thin, discontinuous nature of the confining unit, this unit may only be partly effective in retarding the downward vertical movement of groundwater from the surficial aquifer.

The Castle Hayne aquifer lies below the surficial aquifer and consists primarily of unconsolidated sand, shell fragments, and fossiliferous limestone. Clay, silt, silty and sandy clay, and indurated limestone also occur within the aquifer. The upper part of the aquifer consists primarily of calcareous sand with some continuous and discontinuous thin clay and silt beds. The calcareous sand becomes more limey with depth. The lower part of the aquifer consists of consolidated or poorly consolidated limestone and sandy limestone interbedded with clay and sand.

The Castle Hayne aquifer is about 150 to 350 feet thick, increasing in thickness toward the ocean. The top of the aquifer lies approximately 20 to 73 feet below the ground surface. The top of the

aquifer dips southward and is deepest near the Atlantic coast, east of the New River. The top of the aquifer also forms a basin in the vicinity of Paradise Point. Estimates of hydraulic conductivity indicate a wide variation in range, from 14 to 91 feet per day. Table 1-3 presents estimates of the Castle Hayne aquifer and confining unit hydraulic properties in the vicinity of MCB, Camp Lejeune.

Onslow County and MCB, Camp Lejeune lie in an area where the Castle Hayne aquifer generally contains freshwater; however, the proximity of saltwater in deeper layers just below the aquifer and in the New River estuary is of concern in managing water withdrawals. Over-pumping of the deeper parts of the aquifer could cause encroachment of saltwater. The aquifer generally contains water having less than 250 milligrams per liter (mg/L) chloride throughout the base, except for one USGS well in the southern portion of the base that is screened in the lower portion of the aquifer. Chloride was measured at 960 mg/L in a sample collected in 1989 from this well.

Rainfall in the MCB, Camp Lejeune area enters the ground in recharge areas, infiltrates the soil, and moves downward until it reaches the surficial aquifer. Recharge areas at Camp Lejeune are mainly comprised of interstream areas. In the surficial aquifer, groundwater flows in the direction of lower hydraulic head until it reaches discharge points or fronts. These discharge areas include the New River and its tributaries and the ocean. Though most of the rainfall entering the surficial aquifer discharges to local streams, a relatively small amount infiltrates to the Castle Hayne. The surficial aquifer supplies the primary recharge to the Castle Hayne aquifer. Like the surficial aquifer, the Castle Hayne naturally discharges to the New River and major tributaries; however, pumping of the Castle Hayne may locally influence flow directions.

The potentiometric surface of the surficial aquifer varies seasonally, as seen through the observation of water levels in monitoring wells. The surficial aquifer receives more recharge in the winter than in the summer when much of the water evaporates or is transpired by plants before it can reach the water table. As a result, the potentiometric surface is generally highest in the winter months and lowest in the summer or early fall.

Water levels from wells placed in deeper aquifers, such as the Castle Hayne, were also used to establish potentiometric surfaces. Because the Castle Hayne is at least partially confined from the surficial aquifer and is not influenced by rainfall as strongly as the surficial aquifer, the seasonal variations tend to be slower and smaller than in surficial aquifer.

1.2.8 Ecology

The ecology at MCB Camp Lejeune is discussed in three sections that include ecological communities, sensitive environments and threatened and endangered species.

1.2.8.1 Ecological Communities

MCB, Camp Lejeune is located on North Carolina's coastal plain. A number of natural ecological communities are present within this region. In addition, variations of natural communities have occurred in response to disturbance and intervention (e.g., forest clearing, urbanization). The natural communities found in the area are summarized as follows:

- Mixed Hardwood Forest - Found generally on slopes of ravines. Beech, white oak, tulip, sweetgum, and holly are indicator species.

- Southeastern Evergreen Forest - Dominated by pines, especially longleaf pine.
- Loblolly Pine/Hardwoods Community - Second growth forest that includes loblolly pine with a mix of hardwoods (i.e., oak, hickory, sweetgum, sour gum, red maple, and holly).
- Southern Floodplain Forest - Occurs on the floodplains of rivers. Hardwoods dominate with a variety of species present. Composition of species varies with the amount of moisture.
- Maritime Forest - Develops on the lee side of stable sand dunes protected from the ocean. Live oak is an indicator species along with pine, cedar, yaupon, holly, and laurel oak. Deciduous hardwoods may be present where forest is mature.
- Pocosins - Lowland forest community that develops on highly organic soils that are seasonally flooded. Characterized by plants adapted to drought and acidic soils low in nutrients. Pond pine is the dominant tree with dense layer of evergreen shrubs. Strongly influenced by fire.
- Cypress Tupelo Swamp Forest - Occurs in the lowest and wettest areas of floodplains. Dominated by bald cypress and tupelo.
- Freshwater Marsh - Occurs upstream from tidal marshes and downstream from non-tidal freshwater wetlands. Cattails, sedges, and rushes are present.
- Salt Marsh - Regularly flooded, tidally influenced areas dominated by salt-tolerant grasses. Saltwater cordgrass is a characteristic species. Tidal mud flats may be present during low tide.
- Salt Shrub Thicket - High areas of salt marshes and beach areas behind dunes. Subjected to salt spray and periodic saltwater flooding. Dominated by salt resistant shrubs.
- Dunes/Beaches - Zones from the ocean shore to the maritime forest. Subjected to sand, salt, wind, and water.
- Ponds and Lakes - Low depressional areas where water table reaches the surface or where ground is impermeable. In ponds rooted plants can grow across the bottom. Fish populations in these ponds include redear, bluegill, largemouth bass, and channel catfish.
- Open Water - Marine and estuarine waters as well as all underlying bottoms below the intertidal zone.

MCB, Camp Lejeune covers approximately 150,000 acres or 234 square miles. Marine and estuarine open water account for 26,000 acres and terrestrial and palustrine land account for 85,000 acres. Forests are predominant as terrestrial cover and pine forest is the dominant habitat type. A total of 21,000 acres of the pine forest is loblolly pine, 7700 acres are dominated by longleaf

pine forest, and 3600 acres are dominated by pond pine forest. These pine forests include natural subcommunities that are maintained by fire.

In addition to the pine forest, mixed pine/hardwood forest is present on MCB, Camp Lejeune and accounts for 15,900 acres. An additional 12,100 acres are covered by hardwood forest. Of the wetlands present, estuarine marsh accounts for 700 acres; open freshwater accounts for 200 acres; and dune, beach, and brackish marsh accounts for 2200 acres. Industrial, infrastructure, and administrative areas make up 10,000 acres and artillery impact areas and buffer zones account for 11,000 acres (LeBlond, 1994). The base contains 80 miles of tidal streams, 21 miles of marine shoreline, and 12 freshwater ponds. The soil types range from sandy loams to fine sand and muck, with the dominant series being sandy loam (USMC, 1987).

The base drains primarily to the New River via its tributaries. These tributaries include Northeast Creek, Southwest Creek, Cogdels Creek, Wallace Creek, Frenchs Creek, Bear Head Creek, Brinson Creek, Edwards Creek, and Duck Creek. Site-specific information regarding surface water and drainage features is presented in Section 2.0.

Forested areas within the military reservation are actively managed for timber. Game species are also managed for hunting and ponds are maintained for fishing. Game species managed include wild turkey, white-tailed deer, black bear, grey and fox squirrels, bobwhite quail, eastern cottontail and marsh rabbits, raccoons, and wood ducks. About 150 acres are maintained for wildlife food plots.

1.2.8.2 Sensitive Environments

Two areas on MCB, Camp Lejeune have been registered as designated Natural Areas within the North Carolina Natural Heritage Program. These two areas, which encompass 141 acres, are the Longleaf Pine Natural Area and the Wallace Creek Swamp Natural Area. In addition, 12 other Natural Areas have been recommended for inclusion in the registry.

These Natural Areas contain some of the finest examples of natural communities in North Carolina and support many rare species. A few of these community types are globally rare. The Calcareous Coastal Fringe Forest on the 100-acre midden at Corn Landing is the only known extant example of this community type. Camp Lejeune contains some of the best examples of the following globally-rare, natural community types: Cypress Savanna, Depression Meadow, and Small Depression Pond. The Maritime Evergreen Forest hammocks between Cedar Point and Shell Point are connected by shell tombolos and appear to be a very rare geological formation.

The NC DEHNR's Division of Environmental Management (DEM) has developed guidance pertaining to activities that may impact wetlands (NC DEHNR, 1992). In addition, certain activities affecting wetlands are also regulated by the U.S. Army Corps of Engineers.

The U.S. Fish and Wildlife Service (FWS) has prepared National Wetlands Inventory (NWI) maps for the MCB, Camp Lejeune area. Through stereoscopic analysis of high altitude aerial photographs, wetlands were identified based upon vegetation, visible hydrology, and geography in accordance with Classification of Wetland and Deep-Water Habitats of the United States (Cowardin, et al., 1979). The NWI maps are intended for an initial identification of wetland areas and are not meant to replace an actual wetland delineation survey that may be required by Federal, state and local regulatory agencies.

Site-specific wetland delineations were not conducted at Sites 36, 43, 44, 54, and 86; however, potential wetland areas were noted during the field habitat evaluation. Information regarding potential wetland areas was transferred to the site-specific biohabitat maps provided in Section 2.0. Information regarding sensitive natural areas was reviewed during map preparation and has been transferred to the maps, if applicable.

1.2.8.3 Threatened and Endangered Species

Certain species have been granted protection by the FWS under the Federal Endangered Species Act (16 U.S.C. 1531-1543), and by the North Carolina Wildlife Resources Commission, under the North Carolina Endangered Species Act (G.S. 113-331 to 113-337). The protected species fall into one of the following status classifications: Federal or state endangered, threatened or candidate species; state special concern; state significantly rare; or state watch list. While only the Federal or state threatened or endangered and state special concern species are protected from certain actions, the other classified species may have protection in the future.

Surveys have been conducted to identify threatened and endangered species at MCB, Camp Lejeune and several programs are underway to manage and protect them. Table 1-4 lists federally protected species present at the base and their protected classification. Of these species, the red-cockaded woodpecker, American alligator, and sea turtles are protected by specific regulatory programs.

The red-cockaded woodpecker requires a mature, living longleaf or loblolly pine environment. The birds live in family groups and young are raised cooperatively. At MCB, Camp Lejeune, 2,512 acres of habitat have been identified and marked for protection. Approximately 3,300 acres are in actively managed red-cockaded woodpecker colonies. Research on the bird at MCB, Camp Lejeune began in 1985 and information has been collected to determine home ranges, population size and composition, reproductive success, and habitat use. An annual roost survey is conducted and 36 colonies of birds have been located.

The American alligator is considered a state special concern specie. It is found in freshwater, estuarine, and saltwater wetlands in MCB, Camp Lejeune. Base wetlands are maintained and protected for alligators; signs have been posted where alligators are known to live. Annual surveys of Wallace, Southwest, French, Duck, Mill, and Stone Creeks have been conducted since 1977 to identify alligators and their habitats on base.

Two protected sea turtles, the Atlantic loggerhead and Atlantic green turtle, nest on Onslow Beach at MCB, Camp Lejeune. The green turtle was found nesting in 1980; this sighting was the first time the species had been observed nesting north of Georgia. The turtle returned to nest in 1985. Turtle nests on the beach are surveyed and protected, turtles are tagged, and annual turtle status reports are issued.

Three bird species, piping plover, Bachmans sparrow, and peregrine falcon have also been identified during surveys at MCB, Camp Lejeune. The piping plover is a shore bird. Piping plovers prefer beaches with broad open sandy flats above the high tide line and feed along the edge of incoming waves. Like the piping plover, Bachmans sparrows have very specific habitat requirements. The sparrows live in open stretches of pines with grasses and scattered shrubs for ground cover. Bachmans sparrows were observed at numerous locations throughout southern portion MCB, Camp Lejeune.

In addition to the protected species that breed or forage at MCB, Camp Lejeune, several protected whales migrate through the coastal waters off the base during spring and fall. These include the Atlantic right whale, finback whale, sei whale, and sperm whale. Before artillery or bombing practice is conducted in the area, aerial surveys are made to assure that whales are not present in the impact areas.

A natural heritage resource study was conducted at MCB, Camp Lejeune (LeBlond, 1994) to identify threatened or endangered plants and areas of significant natural interest. During the resource study 55 rare plant species were documented from Camp Lejeune. These include 1 specie that is classified as Federal Endangered, 1 specie that is classified as Federally Threatened, 9 that are candidates for federal listing as Endangered or Threatened, 4 that are listed as Endangered or Threatened in the State of North Carolina, and 27 species that are State Rare or State Special Concern. These species are summarized on Table 1-4. In addition, species that are candidates for state listing or are on the North Carolina state watch list were noted.

1.2.9 Land Use Demographics

MCB, Camp Lejeune encompasses an area of approximately 234 square miles. The Installation border is approximately 70 miles, including 21 miles of ocean front and Intracoastal Waterway. Recently, MCB, Camp Lejeune acquired approximately 41,000 additional acres in the Greater Sandy Run area. Table 1-5 provides a breakdown of land uses within the developed portion of the facility.

Land use within MCB, Camp Lejeune is influenced by topography and ground cover, environmental policy, and base operational requirements. Much of the land within MCB, Camp Lejeune consists of freshwater swamps that are wooded and largely unsuitable for development. In addition, 3,000 acres of sensitive estuary and other areas set aside for the protection of threatened and endangered species are to remain undeveloped. Operational restrictions and regulations, such as explosive quantity safety distances, impact-weighted noise thresholds, and aircraft landing and clearance zones, may also greatly constrain and influence development (Master Plan, 1988).

The combined military and civilian population of the MCB, Camp Lejeune and Jacksonville area is approximately 112,000. Nearly 90 percent of the surrounding population resides within urbanized areas. The presence of MCB, Camp Lejeune has been the single greatest factor contributing to the rapid population growth of Jacksonville and adjacent communities, particularly during the period from 1940 to 1960.

1.2.9.1 MCAS, New River

MCAS, New River encompasses 2,772 acres and is located in the northwestern portion of the MCB, Camp Lejeune complex. MCAS, New River includes air support activities, troop housing, and personnel support facilities that surround the aircraft operations and maintenance areas. The air station primarily functions as a helicopter base, however, an increasing contingent of fixed-wing aircraft are also supported. Its present mission is to maintain and operate facilities that provide services and material to sustain operations of Marine Air Groups (MAG) 26 and 29, the two tenant commands. MCAS, New River also maintains a number of other activities and units as designated by the Commandant of the Marine Corps and the Chief of Naval Operations.

1.2.10 Meteorology

Although coastal North Carolina lacks distinct wet and dry seasons, there is some seasonal variation in average precipitation. July tends to receive the most precipitation, and rainfall amounts during summer are generally the greatest. Daily showers during the summer are not uncommon, nor are periods of one or two weeks without rain. Convective showers and thunderstorms contribute to the variability of precipitation during the summer months. October tends to receive the least amount of precipitation, on average. Throughout the winter and spring precipitation occurs primarily in the form of migratory low pressure storms. MCB, Camp Lejeune's average yearly rainfall is 52.4 inches. Table 1-6 presents a climatic summary of data collected during 35 years (January 1955 to December 1990) of observations at MCAS New River.

Coastal Plain temperatures are moderated by the proximity of the Atlantic Ocean, which effectively reduces the average daily fluctuation of temperature. Lying 50 miles offshore at its nearest point, the Gulf Stream tends to have little direct effect on coastal temperatures. The southern reaches of the cold Labrador Current offset any warming effect the Gulf Stream might otherwise provide.

MCB, Camp Lejeune experiences hot and humid summers; however, ocean breezes frequently produce a cooling effect. The winter months tend to be mild, with occasional brief cold spells. Average daily temperatures range from 34°F to 54°F in January, the coldest month, and 72°F to 89°F in July, the hottest month. The average relative humidity, between 78 and 89 percent, does not vary greatly from season to season.

Observations of sky conditions indicate yearly averages of approximately 112 days clear, 105 partly cloudy, and 148 cloudy. Measurable amounts of rainfall occur 118 days per year, on the average. Prevailing winds are generally from the south-southwest 10 months of the year and from the north-northwest during September and October. The average wind speed at MCAS, New River is seven miles per hour.

1.3 Background and Setting of Site 86

The following section provides both the location and setting of Site 86. A brief summary of past waste disposal activities at Site 86 is also provided within this section.

1.3.1 Site Location and Setting

Site 86 is located on the southwest corner of the Foster and Campbell Street intersection, within the operations area of MCAS New River (see Figure 1-1). The site is comprised of a lawn area surrounded by buildings, asphalt roads, and parking lots. Concrete pylons, upon which electric and steam overhead utilities are mounted, line the northern, western, and southern boundaries of the site. Campbell Street borders the site to the north and Foster Street lies adjacent to the east. Immediately to the south of the study area is Building AS-502, the MCAS fire station. The entrance road to the fire station borders the study area to the west. Figure 1-5 presents a site map of the Above Ground Storage Tank Area.

The ground surface at Site 86 gently slopes to the south, toward a drainage ditch and culvert. Storm water drains that are located along Campbell Street receive runoff from only the northernmost portion of the study area. Stormwater from Site 86 eventually discharges into the New River, which lies approximately three quarters of a mile to the east.

1.3.2 Site History

Site 86 served as a storage area for petroleum products from 1954 to 1988. In 1954, three 25,000-gallon above ground storage tanks (ASTs) were installed within an earthen berm. Additionally, a small pump house was constructed to transfer fuel oil to and from the ASTs. The three tanks were reportedly used for No.6 fuel oil storage until 1979. From 1979 to 1988 the tanks were then used for temporary storage of waste oil (O'Brien & Gere, 1992). The three tanks were emptied in 1988 and are believed to have been removed in 1992. Today, the former location of the tanks is grass-covered and only a very slight depression remains.

1.4 Previous Investigations

Site 86 was added to the list of IRP sites in 1992, after both the Initial Assessment Study and the Confirmation Study at MCB, Camp Lejeune had been completed. Consequently, neither investigation report mentions Site 86 as a potential waste site. The following subsections describe preliminary site investigation and site assessment activities at OU No.6, Site 86.

1.4.1 Preliminary Site Investigation

A preliminary site investigation was conducted in November 1990 by Dewberry and Davis, Inc. During this investigation a total of eleven soil boring samples were analyzed for total petroleum hydrocarbons (TPH) and volatile organic compounds (VOCs). The soil samples were retained from areas immediately adjacent to the ASTs and ancillary piping. Results from two soil samples with positive TPH detections are as follows:

- 7000 milligrams per kilogram (mg/kg) TPH in sample SB-5, near valves on west side of ASTs, retained from 1-2 feet below ground surface (bgs).
- 200 mg/kg total TPH in sample SB-7, near valves on east side of ASTs, obtained from 0.5-2 feet bgs.

TPH results from the other nine soil samples were below the detection limit of 10 parts per million (ppm). Soil analyses for VOCs yielded concentrations of chloroform, methylene chloride, 1,1,1-trichloroethane, and 1,1,2-trichlorotrifluoroethane. The maximum VOC concentration was that of 1,1,2-trichlorotrifluoroethane at 61 mg/kg. Based upon the dispersion and concentration of detected compounds in primarily surface soils at Site 86, the preliminary site investigation concluded that observations were indicative of localized surface spills.

1.4.2 Site Assessment

In 1992, a site assessment (SA) was conducted at Site 86 by O'Brien and Gere Engineers, Inc. (1992). The SA sought to determine the nature and presence of subsurface contamination that may have resulted from the temporary storage of waste petroleum products in the three ASTs located on site. As part of the SA, both groundwater and soil investigations were conducted. In addition, estimates of hydraulic conductivity were also calculated for each of the monitoring wells installed during the SA. The following subsections briefly describe the results and conclusions of the SA at Site 86. Figure 1-6 provides the specific SA sampling locations.

1.4.2.1 Groundwater

As part of the groundwater investigation at Site 86, a total of seven nested pairs of wells were installed. At each of the 7 well nests a 30-foot and a 15-foot monitoring well was installed. Table 1-7 provides well construction details of the monitoring wells installed during the SA at Site 86. In addition to the monitoring wells, four supplemental groundwater samples were obtained from hydropunch locations.

Groundwater samples were submitted for analysis of organic compounds using EPA methods 601, 602, and 610. Five of the 14 monitoring wells (86-GW03, 86-GW04, 86-GW06, 86-GW10, and 86-GW12) had detectable concentrations of organic compounds above North Carolina Water Quality Standards (NCWQS). The following eight organic compounds were detected in at least one of the groundwater samples:

- benzene
- toluene
- 1,1-dichloroethane
- 1,2-dichloroethylene
- trichloroethylene
- tetrachloroethylene
- chloroethane
- 1,1,1-trichloroethane

Benzene, trichloroethylene (TCE), and tetrachloroethylene were detected above their corresponding NCWQS in one or more of the Site 86 groundwater samples. Toluene and 1,1,1-trichloroethane were each detected below their corresponding NCWQS. The organic compounds 1,1-dichloroethane and 1,2-dichloroethylene were detected in at least one of the five monitoring wells with organic contamination. Table 1-8 provides a summary of the groundwater analytical results.

In addition to groundwater analyses, a generalized measurement of hydraulic conductivity was estimated for Site 86 using data collected from each of the 14 monitoring wells. Values of hydraulic conductivity were calculated using Horselov's formula and the change of water level versus the change in time. Using this method, the mean hydraulic conductivity for Site 86 was calculated to be 0.88 feet per day.

1.4.2.2 Soil

A total of 11 soil borings were completed as part of the soil investigation at Site 86 (refer to Figure 1-6). Four of the 11 soil borings were situated within the former AST area. The remaining seven soil borings were converted to monitoring wells, one from each well nest. One soil sample from immediately above the water table, that ranged from 9 to 11 feet bgs, and one soil sample from five feet above the water table were collected at each boring location. Each of the 22 soil samples were analyzed for TPH. In addition to TPH analyses, five of the soil samples (86-GW01, 86-GW04, 86-GW06, 86-GW08, and 86-GW12) were analyzed for flashpoint and pH, and two soil samples (86-GW02 and 86-GW06) were selected for toxicity characteristic leaching procedure (TCLP) analyses.

TPH results from 21 of the 22 soil samples submitted for TPH analysis were below the North Carolina action level of 10 mg/kg. The soil sample that exceeded the state TPH action level was obtained within the former tank area, from a depth of four to six feet bgs. The TPH concentration at this location was 124 mg/kg. Additionally, results of the pH analyses ranged from 4.8 to 7.6; supplemental flashpoint tests and TCLP results were negative.

1.5 Remedial Investigation Objectives

The purpose of this section is to define the RI objectives that were intended to characterize past waste disposal activities at Site 86, assess potential impacts to public health and environment, and provide feasible alternatives for consideration during preparation of the ROD. The remedial objectives presented in this section have been identified through review and evaluation of existing background information, assessment of potential risks to public health and environment, and consideration of feasible remediation technologies and alternatives. As part of the remedial investigation at Site 86, soil and groundwater investigations were conducted. The information gathered during these investigations was intended to fill previously existing data gaps and employed to generate human health and ecological risk values. Table 1-9 presents the RI objectives identified for Site 86. In addition, the table provides a general description of the study or investigation efforts that were conducted to obtain the requisite information.

1.6 References

Atlantic Division, Naval Facilities Engineering Command. January 1988. Camp Lejeune Complex Master Plan and Capital Improvements Plan Update. Prepared for the Commanding General, Marine Corps Base, Camp Lejeune, North Carolina.

Baker Environmental, Inc. December 1994. Remedial Investigation/Feasibility Study Work Plan for Operable Unit No. 6 (Sites 36, 43, 44, 54, and 86), Marine Corps Base Camp Lejeune, North Carolina. Final. Prepared for the Department of the Navy, Naval Facilities Engineering Command, Atlantic Division, Norfolk, Virginia.

Baker Environmental, Inc. May 1995. Site Management Plan for Marine Corps Base Camp Lejeune, North Carolina. Draft. Prepared for the Department of the Navy, Naval Facilities Engineering Command, Atlantic Division, Norfolk, Virginia.

Cardinell, A.P., Berg, S.A., and Lloyd, O.B. 1993. Hydrogeologic Framework of U.S. Marine Corps Base at Camp Lejeune, North Carolina: U.S. Geological Survey Water Resources Investigation Report. Report No. 93-4049.

Cowardin, Lewis M., Virginia Carter, Francis C. Golet, and Edward T. LaRoe. December 1979. Classification of Wetlands and Deepwater Habitats of the United States. Performed for U.S. Department of the Interior, Fish and Wildlife Service, Office of Biological Services - FWS/OBS-79/31.

Environmental Science and Engineering, Inc. (ESE) 1990. Site Summary Report. Final. Marine Corps Base, Camp Lejeune, North Carolina. Prepared for the Department of the Navy, Naval Facilities Engineering Command, Atlantic Division, Norfolk, Virginia. ESE Project No. 49-02036.

Environmental Science and Engineering, Inc. (ESE) 1988. Characterization Step Report for Hadnot Point Industrial Area. Marine Corps Base, Camp Lejeune, North Carolina. Prepared for the Department of the Navy, Naval Facilities Engineering Command, Atlantic Division, Norfolk, Virginia. ESE Project No. 49-02036-0150.

Federal Facilities Agreement (FFA) Between United States Environmental Protection Agency, Region IV; the North Carolina Department of Environment, Health and Natural Resources and

United States Department of Navy for Marine Corps Base, Camp Lejeune and Marine Corps Air Station, New River, North Carolina. December 1989.

Harned, D.A., Lloyd, O.B., Jr., and Treece, M.W., 1989. Assessment of Hydrologic and Hydrogeologic Data at Camp Lejeune Marine Corps Base, North Carolina: U.S. Geological Survey Water Resources Investigation. Report 89-4096, p. 64.

LeBlond, Richard J., John O. Fussell, and Alvin L. Broswell. February 1994. Inventory of Rare Species, Natural Communities, and Critical Areas of the Camp Lejeune Marine Corps Base, North Carolina. North Carolina Natural Heritage Program, Division of Parks and Recreation, Department of Environment, Health, and Natural Resources, Raleigh, North Carolina.

North Carolina Department of Environment, Health, and Natural Resources (NC DEHNR) May 1992. Interim Guidance for Wetlands Protection. Division of Environment, Water Quality Section.

O'Brien & Gere, Inc. June 1992. Site Assessment of Tanks AS419 - AS421, Marine Corps Air Station, New River, North Carolina. Prepared for the Department of the Navy, Naval Facilities Engineering Command, Atlantic Division, Norfolk, Virginia. Project No. 62470-90-R-7626.

U.S. Department of the Interior (USDI). March 1982. National Wetland Inventory Map, Camp Lejeune, N.C. Fish and Wildlife Service.

U.S. Marine Corps, MCB, Camp Lejeune (USMC). 1987. Multiple-Use Natural Resources Management Plan. Fish and Wildlife Division, Environmental Management Department, Marine Corps Base, Camp Lejeune, North Carolina.

Water and Air Research, Inc. (WAR) April 1983. Initial Assessment Study of Marine Corps Base Camp Lejeune, North Carolina. Prepared for the Department of the Navy, Naval Energy and Environmental Support Activity, Port Hueneme, California.

SECTION 1.0 TABLES

TABLE 1-1

GEOLOGIC AND HYDROGEOLOGIC UNITS OF
NORTH CAROLINA'S COASTAL PLAIN
REMEDIAL INVESTIGATION, CTO-0303
MCAS, NEW RIVER, NORTH CAROLINA

Geologic Units			Hydrogeologic Units
System	Series	Formation	Aquifer and Confining Unit
Quaternary	Holocene/Pleistocene	Undifferentiated	Surficial aquifer
Tertiary	Pliocene	Yorktown Formation ⁽¹⁾	Yorktown confining unit
	Miocene	Eastover Formation ⁽¹⁾	Yorktown Aquifer
		Pungo River Formation ⁽¹⁾	Pungo River confining unit
			Pungo River Aquifer
		Belgrade Formation ⁽²⁾	Castle Hayne confining unit
	Oligocene	River Bend Formation	Castle Hayne Aquifer
	Eocene	Castle Hayne Formation	Beaufort confining unit ⁽³⁾
	Paleocene	Beaufort Formation	Beaufort Aquifer
Cretaceous	Upper Cretaceous	Peedee Formation	Peedee confining unit
			Peedee Aquifer
		Black Creek and Middendorf Formations	Black Creek confining unit
			Black Creek Aquifer
		Cape Fear Formation	Upper Cape Fear confining unit
			Upper Cape Fear Aquifer
	Lower Cape Fear confining unit		
		Lower Cape Fear Aquifer	
Lower Cretaceous ⁽¹⁾	Unnamed deposits ⁽¹⁾	Lower Cretaceous confining unit	
		Lower Cretaceous Aquifer ⁽¹⁾	
Pre-Cretaceous basement rocks		--	--

Note:

- (1) Geologic and hydrologic units probably not present beneath MCB, Camp Lejeune.
- (2) Constitutes part of the surficial aquifer and Castle Hayne confining unit in the study area.
- (3) Estimated to be confined to deposits of Paleocene age in the study area.

Source: Harned et al., 1989.

TABLE 1-2

**SUMMARY OF HYDRAULIC PROPERTIES
UNRELATED SITE INVESTIGATIONS
REMEDIAL INVESTIGATION, CTO-0303
MCAS, NEW RIVER, NORTH CAROLINA**

Well No.	Hydraulic Conductivity Falling Head Test		Hydraulic Conductivity Rising Head Test		Transmissivity	Storativity
	ft/day	cm/sec	ft/day	cm/sec	gal/day/ft	
MW-30A	1.18	4.16E-04	1.5	5.31E-04	--	--
MW-31A	0.346	1.22E-04	0.269	9.51E-05	--	--
MW-35A	0.119	4.20E-05	0.116	4.06E-05	--	--
MW-32B	6.22	2.20E-03	5.15	1.82E-03	--	--
MW-36B	2.91	1.03E-03	3.2	1.13E-03	--	--
MW-37B	7.06	2.49E-03	6.44	2.27E-03	--	--
GWD-1	6.8	2.40E-03	6.03	2.13E-03	--	--
122MW-3	0.25	8.80E-05	0.015	5.30E-06	--	--
122MW-5	0.47	1.70E-04	0.034	1.20E-05	--	--
122MW-12	0.068	2.40E-05	0.0085	3.00E-06	--	--
MW-13 ⁽¹⁾	0.0554	1.96E-05	0.0032	1.13E-06	--	--
MW-14 ⁽¹⁾	0.188	6.62E-05	7.26E-04	2.56E-07	--	--
MW-3 ⁽²⁾	--	--	0.75	2.60E-04	--	--
MW-4 ⁽²⁾	--	--	0.27	9.50E-05	--	--
MW-11 ⁽²⁾	--	--	0.37	1.30E-04	--	--
MW-21 ⁽²⁾	--	--	0.46	1.60E-04	5.5	0.028
RW-1 ⁽²⁾	--	--	--	--	54	--
MW-18 ⁽²⁾	--	--	--	--	790	0.014

Note: All data compiled from unrelated Baker Investigations with the MCAS, New River operations area.

⁽¹⁾ AS 527

⁽²⁾ Campbell Street Fuel Farm
A = Upper Surficial Aquifer
B = Lower Surficial Aquifer

TABLE 1-3

HYDRAULIC PROPERTY ESTIMATES OF THE CASTLE HAYNE AQUIFER
 REMEDIAL INVESTIGATION, CTO-0303
 MCAS, NEW RIVER, NORTH CAROLINA

Hydraulic Properties	USGS Phase I Study ⁽¹⁾	USGS Aquifer Test ⁽²⁾	ESE, Inc. ⁽³⁾	DEHNR Aquifer Test ⁽⁴⁾	RASA Estimate ⁽⁵⁾
Aquifer transmissivity (cubic foot per day per square foot times foot of aquifer thickness)	4,300 to 24,500 average 9,500	1,140 to 1,325	820 to 1,740 average 1,280	900	10,140 to 26,000
Aquifer hydraulic conductivity (foot per day)	14 to 82 average 35	20 to 60	--	18 to 91 average 54	45 to 80 average 65
Aquifer storage coefficient (dimensionless)	--	0.0002 to 0.00022	0.0005 to 0.001 average 0.0008	0.0019	--
Confining-unit vertical hydraulic conductivity (foot per day)	--	0.03 to 0.41	0.0014 to 0.051 average 0.0035	--	--

Note:

- (1) Analysis of specific capacity data from Harned and others (1989).
- (2) Aquifer test at well HP-708.
- (3) Aquifer test at Hadnot Point well HP-462 from Environmental Sciences and Engineering, Inc. (1988).
- (4) Unpublished aquifer test data at well X24s2x, from DEHNR well records (1985).
- (5) Transmissivities based on range of aquifer thickness and average hydraulic conductivity from Winner and Coble (1989).

Source: Cardinell, et al., 1993.

TABLE 1-4

**PROTECTED SPECIES WITHIN MCB, CAMP LEJEUNE
REMEDIAL INVESTIGATION, CTO-0303
MCAS, NEW RIVER, NORTH CAROLINA**

Species	Protected Classification
Animals:	
American alligator (<i>Alligator mississippiensis</i>)	SC
Bachmans sparrow (<i>Aimophila aestivalis</i>)	FCan, SC
Green (Atlantic) turtle (<i>Chelonia m. mydas</i>)	T(f), T(s)
Loggerhead turtle (<i>Caretta caretta</i>)	T(f), T(s)
Peregrine falcon (<i>Falco peregrinus</i>)	E(f), E(s)
Piping plover (<i>Charadrius melodus</i>)	T(f), T(s)
Red-cockaded woodpecker (<i>Picoides borealis</i>)	E(f), E(s)
Southern Hognose Snake (<i>Heterodon simus</i>)	FCan, SR
Diamondback Terrapin (<i>Malaclemys terrapin</i>)	FCan, SC
Carolina Gopher Frog (<i>Rana capito capito</i>)	FCan, SC
Cooper's Hawk (<i>Accipiter cooperii</i>)	SC
Eastern Diamondback Rattlesnake (<i>Crotalus adamanteus</i>)	SR
Eastern Coral Snake (<i>Micrurus fulvius</i>)	SR
Pigmy Rattlesnake (<i>Sistrurus miliarius</i>)	SR
Black Bear (<i>Ursus americanus</i>)	SR
Plants:	
Rough-leaf loosestrife (<i>Lysimachia asperulifolia</i>)	E(f), E(s)
Seabeach Amaranth (<i>Amaranthus pumilus</i>)	T(f), T(s)
Chapman's Sedge (<i>Carex chapmanii</i>)	FCan
Hirst's Witchgrass (<i>Dichanthelium</i> sp.)	FCan
Pondspice (<i>Litsea aestivalis</i>)	FCan
Boykin's Lobelia (<i>Lobelia boykinii</i>)	FCan
Loose Watermilfoil (<i>Myriophyllum laxum</i>)	FCan, T(s)
Awned Meadowbeauty (<i>Rhexia aristosa</i>)	FCan, T(s)
Carolina Goldenrod (<i>Solidago pulchra</i>)	FCan, E(s)
Carolina Asphodel (<i>Tofieldia glabra</i>)	FCan
Venus Flytrap (<i>Dionaea muscipula</i>)	FCan
Flaxleaf Gerardia (<i>Agalinis linifolia</i>)	SR
Pinebarrens Goober Grass (<i>Amphicarpum purshii</i>)	SR
Longleaf Three-awn (<i>Aristida palustris</i>)	SR
Pinebarrens Sandreed (<i>Calamovilfa brevipilis</i>)	E(s)
Warty Sedge (<i>Carex verrucosa</i>)	SR
Smooth Sawgrass (<i>Cladium mariscoides</i>)	SR
Leconte's Flatsedge (<i>Cyperus lecontei</i>)	SR
Erectleaf Witchgrass (<i>Dichanthelium erectifolium</i>)	SR
Horsetail Spikerush (<i>Eleocharis equisetoides</i>)	SR
Sand Spikerush (<i>Eleocharis montevidensis</i>)	SR

TABLE 1-4 (Continued)

**PROTECTED SPECIES WITHIN MCB, CAMP LEJEUNE
REMEDIAL INVESTIGATION, CTO-0303
MCB, CAMP LEJEUNE, NORTH CAROLINA**

Species	Protected Classification
Flaxleaf Seedbox (<i>Ludwigia linifolia</i>)	SR
Torrey's Muhley (<i>Muhlenbergia torreyana</i>)	E(s)
Southeastern Panic Grass (<i>Panicum tenerum</i>)	SR
Spoonflower (<i>Peltandra sagittifolia</i>)	SR
Shadow-witch (<i>Ponthieva racemosa</i>)	SR
West Indies Meadowbeauty (<i>Rhexia cubensis</i>)	SR
Pale Beakrush (<i>Rhynchospora pallida</i>)	SR
Longbeak Baldsedge (<i>Rhynchospora scirpoides</i>)	SR
Tracy's Beakrush (<i>Rhynchospora tracyi</i>)	SR
Canby's Bulrush (<i>Scirpus etuberculatus</i>)	SR
Slender Nutrush (<i>Scleria minor</i>)	SR
Lejeune Goldenrod (<i>Solidago</i> sp.)	SR
Dwarf Bladderwort (<i>Utricularia olivacea</i>)	T(s)
Elliott's Yellow-eyed Grass (<i>Xyris elliotii</i>)	SR
Carolina Dropseed (<i>Sporobolus</i> sp.)	T(s)

Legend:

- E(f) = Federal Endangered
- T(f) = Federal Threatened
- Fcan = Candidate for Federal Listing
- E(s) = State Endangered
- T(s) = State Threatened
- SC = State Special Concern
- SR = State Rare

Source: LeBlond, 1994

TABLE 1-5

**LAND UTILIZATION WITHIN DEVELOPED AREAS OF MCB, CAMP LEJEUNE
REMEDIAL INVESTIGATION, CTO-0303
MCAS, NEW RIVER, NORTH CAROLINA**

Geographic Area	Operation	Training (Instruc.)	Maintenance	Supply/ Storage	Medical	Admin- istration	Family Housing	Troop Housing	CM	CO	Recreation	Utility	Total
Hadnot Point	31 (2.9)	15 (1.4)	154 (14.3)	157 (14.4)	10 (0.9)	122 (11.3)	22 (2.0)	196 (18.1)	115 (10.7)	36 (3.3)	182 (16.9)	40 (3.7)	1,080 (100)
Paradise Point	1 (0)		3 (0.4)	1 (0)			343 (34)	19 (1.9)	31 (3.1)		610 (60.4)	2 (0.2)	1,010 (100)
Berkeley Manor/ Watkins							406 (80)		41 (8.1)	1 (0.2)	57 (11.2)	2 (0.5)	507 (100)
Midway Park		1 (0.4)		2 (0.7)		2 (0.7)	248 (92.2)		8 (3.0)	3 (1.1)	4 (1.5)	1 (0.4)	269 (100)
Tarawa Terrace I and II			3 (0.5)			1 (0.3)	428 (77.4)		55 (9.9)	11 (2.0)	47 (8.5)	8 (1.4)	553 (100)
Knox Trailer							57 (100)						
French Creek	8 (1.4)	1 (0.2)	74 (12.7)	266 (45.6)	3 (0.5)	7 (1.2)		122 (20.9)	22 (3.8)	6 (1.0)	74 (12.7)		583 (100)
Courthouse Bay		73 (28.6)	28 (10.9)	14 (5.5)		12 (4.7)	12 (4.7)	43 (16.9)	15 (5.9)	4 (1.6)	43 (16.9)	11 (4.3)	255 (100)
Onslow Beach	6 (9.8)	1 (1.6)	3 (4.8)	2 (3.2)	1 (1.6)	2 (3.2)		2 (3.2)	12 (19.3)		25 (40.3)	8 (13.0)	62 (100)
Rifle Range		1 (1.3)	1 (1.3)	7 (8.8)	1 (1.3)	5 (6.3)	7 (8.8)	30 (37.5)	5 (6.3)	1 (1.3)	9 (11.3)	13 (16.3)	80 (100)
Camp Geiger	4 (1.9)	15 (6.9)	19 (8.8)	50 (23.1)		23 (10.6)		54 (25.0)	27 (12.5)	2 (1.0)	16 (7.4)	6 (2.8)	216 (100)
Montford Point	6 (2.6)	48 (20.5)	2 (0.9)	4 (1.7)	2 (0.9)	9 (3.9)		82 (35.2)	20 (8.6)	1 (0.4)	49 (21.0)	10 (4.3)	233 (100)
Base-Wide Misc.	1 (0.8)			87 (68.0)		3 (2.3)			19 (14.8)			18 (14.1)	128 (100)
TOTAL	57 (1.)	155 (3.1)	287 (5.7)	590 (11.7)	17 (0.38)	186 (3.7)	1,523 (30.2)	548 (10.8)	370 (7.4)	65 (1.3)	1,116 (22.2)	119 (2.4)	5,033 (100)

Notes:

Numbers without parentheses represent total acres.
Numbers within parentheses represent percentage of total acres.
Source: Master Plan, 1988

TABLE 1-6

CLIMATIC DATA SUMMARY
 MARINE CORPS AIR STATION, NEW RIVER
 REMEDIAL INVESTIGATION, CTO-0303
 MCAS, NEW RIVER, NORTH CAROLINA

	Precipitation (Inches)			Relative Humidity (Percent)	Temperature (Fahrenheit)			Mean Number of Days With				
	Maximum	Minimum	Average		Maximum	Minimum	Average	Precipitation		Temperature		
								>=0.01"	>=0.5"	>=90F	>=75F	<=32F
January	7.5	1.4	4.0	79	54	34	44	11	2	0	1	16
February	9.1	.9	3.9	78	57	36	47	10	3	0	2	11
March	8	.8	3.9	80	64	43	54	10	3	*	5	5
April	8.8	.5	3.1	79	73	51	62	8	2	1	13	*
May	8.4	.6	4.0	83	80	60	70	10	3	2	25	0
June	11.8	2.2	5.2	84	86	67	77	10	4	7	29	0
July	14.3	4.0	7.7	86	89	72	80	14	5	13	31	0
August	12.6	1.7	6.2	89	88	71	80	12	4	11	31	0
September	12.8	.8	4.6	89	83	66	75	9	3	4	27	0
October	8.9	.6	2.9	86	75	54	65	7	2	*	17	*
November	6.7	.6	3.2	83	67	45	56	8	2	0	7	3
December	6.6	.4	3.7	81	58	37	48	9	2	0	2	12
Annual	65.9	38.2	52.4	83	73	53	63	118	35	39	189	48

Note:

* = Mean no. of days less than 0.5 days

Source: Naval Oceanography Command Detachment, Asheville, North Carolina. Measurements obtained from January 1955 to December 1990.

TABLE 1-7

**SUMMARY OF WELL CONSTRUCTION DETAILS
SITE ASSESSMENT
SITE 86, ABOVE GROUND STORAGE TANK AREA
REMEDIAL INVESTIGATION, CTO-0303
MCAS, NEW RIVER, NORTH CAROLINA**

Well No.	Date Installed	Top of PVC Casing Elevation (feet, above msl) ⁽¹⁾	Ground Surface Elevation (feet, above msl)	Boring Depth (feet, below ground surface) ⁽²⁾	Well Depth (feet, below ground surface) ⁽²⁾	Screen Interval Depth (feet, below ground surface) ⁽²⁾	Sand Pack Interval Depth (feet, below ground surface) ⁽²⁾	Bentonite Interval Depth (feet, below ground surface) ⁽²⁾
86-GW01	1/21/92	19.39	17.79	15	15	5-15	3-15	1-3
86-GW02IW	1/22/92	18.86	17.77	30	30	20-30	16-30	8-16
86-GW03	1/21/92	18.20	15.94	14	14	4-14	2-14	1-2
86-GW04IW	1/22/92	18.16	15.21	30	30	20-30	18-30	16-18
86-GW05	1/21/82	19.43	16.94	15	15	5-15	3-15	2-3
86-GW06IW	1/22/92	19.21	16.77	30	30	20-30	18-30	16-18
86-GW07	1/21/92	20.14	17.47	15	15	5-15	3-15	1-3
86-GW08IW	1/22/92	19.92	17.52	30	30	20-30	18-30	16-18
86-GW09	1/24/92	18.50	15.65	15	15	5-15	3-15	1-3
86-GW10IW	1/24/92	17.95	15.67	30	30	20-30	18-30	16-18
86-GW11	1/24/92	19.81	16.89	15	15	5-15	3-15	1-3
86-GW12IW	1/24/92	18.74	17.02	30	30	20-30	18-30	16-18

Notes:

⁽¹⁾ msl = mean sea level

⁽²⁾ Measurements taken from compiled well logs (O'Brien & Gere).

Horizontal positions are referenced to N.C. State Plane Coordinate System (NAD 27) CF = 0.9999216 from USMC Monument Toney.

Vertical datum NGVD 29.

TABLE 1-7 (Continued)

**SUMMARY OF WELL CONSTRUCTION DETAILS
SITE ASSESSMENT
SITE 86, ABOVE GROUND STORAGE TANK AREA
REMEDIAL INVESTIGATION, CTO-0303
MCAS, NEW RIVER, NORTH CAROLINA**

Well No.	Date Installed	Top of PVC Casing Elevation (feet, above msl) ⁽¹⁾	Ground Surface Elevation (feet, above msl)	Boring Depth (feet, below ground surface) ⁽²⁾	Well Depth (feet, below ground surface) ⁽²⁾	Screen Interval Depth (feet, below ground surface) ⁽²⁾	Sand Pack Interval Depth (feet, below ground surface) ⁽²⁾	Bentonite Interval Depth (feet, below ground surface) ⁽²⁾
86-GW13	1/27/92	16.88	17.09	15	15	5-15	3-15	1-3
86-GW14IW	1/27/92	16.91	17.11	30	30	20-30	18-30	16-18

Notes:

⁽¹⁾ msl = mean sea level

⁽²⁾ Measurements taken from compiled well logs (O'Brien & Gere).

Horizontal positions are referenced to N.C. State Plane Coordinate System (NAD 27) CF = 0.9999216 from USMC Monument Toney.

Vertical datum NGVD 29.

TABLE 1-8

DETECTED ORGANIC CONTAMINANTS IN GROUNDWATER
 SITE ASSESSMENT
 SITE 86, ABOVE GROUND STORAGE TANK AREA
 REMEDIAL INVESTIGATION, CTO-0303
 MCAS, NEW RIVER, NORTH CAROLINA

Sample Number: Date Sampled:	Standards		86-GW02	86-GW03	86-GW04	86-GW06	86-GW08	86-GW12	H9
	MCL ⁽¹⁾	NCWQS ⁽²⁾							
Parameter: Units (µg/L)	MCL ⁽¹⁾	NCWQS ⁽²⁾	86-GW02	86-GW03	86-GW04	86-GW06	86-GW08	86-GW12	H9
Benzene	5	1	ND	ND	6	1	ND	ND	ND
Toluene	1,000	1,000	350	ND	ND	ND	2	1	ND
1,1-Dichloroethane	5	700	ND	16	ND	ND	ND	ND	ND
1,2-Dichloroethylene	70 ⁽³⁾	--	ND	ND	94	ND	ND	ND	ND
Trichloroethylene	5	2.8	ND	ND	280	4	ND	1	ND
Perchloroethylene	5	0.7	ND	4	ND	ND	ND	4	ND
1,1,1-Tetrachloroethane	200	200	ND	ND	ND	ND	ND	ND	2

Notes:

⁽¹⁾ NCWQS - North Carolina administrative code, Title 15A, NCDEHNR, Subchapter 2L, Section .0202 - Water Quality Standards for groundwater.

⁽²⁾ Federal maximum contaminant levels (MCLs) established under the Safe Drinking Water Act of 1986.

⁽³⁾ Value is for cis-1,2-dichloroethylene.

H - Hydropunch

ND - Not detected

(--) - Standard or criteria not available

Source: ESE, Site Summary Report, Final. September, 1990.

TABLE 1-9

**REMEDIAL INVESTIGATION OBJECTIVES
SITE 86, ABOVE GROUND STORAGE TANK AREA
REMEDIAL INVESTIGATION, CTO-0303
MCAS, NEW RIVER, NORTH CAROLINA**

Medium or Area of Concern	RI/FS Objective	Criteria for Meeting Objective	Proposed Investigation/Study
1. Soil	1a. Assess the extent of soil contamination in the former AST area.	Characterize contaminant levels in surface and subsurface soils at the former AST area.	Soil Investigation
	1b. Assess human health and ecological risks associated with exposure to surface soils at Site 86.	Characterize contaminant levels in surface soils at Site 86.	Soil Investigation Risk Assessment
2. Groundwater	2a. Determine whether contamination from soils is migrating to groundwater.	Characterize subsurface soil and leaching potential. Characterize groundwater.	Groundwater Investigation
	2b. Assess health risks posed by potential future usage of the shallow and deep groundwater.	Evaluate groundwater quality and compare to groundwater criteria and risk-based action levels.	Groundwater Investigation Risk Assessment
	2c. Assess nature and extent of shallow and deep groundwater contamination.	Characterize shallow and deep groundwater quality.	Groundwater Investigation
	2d. Define hydrogeologic characteristics for fate and transport evaluation and remedial technology evaluation, if required.	Estimate hydrogeologic characteristics of the shallow aquifer (flow direction, transmissivity, permeability, etc.).	Groundwater Investigation

SECTION 1.0 FIGURES

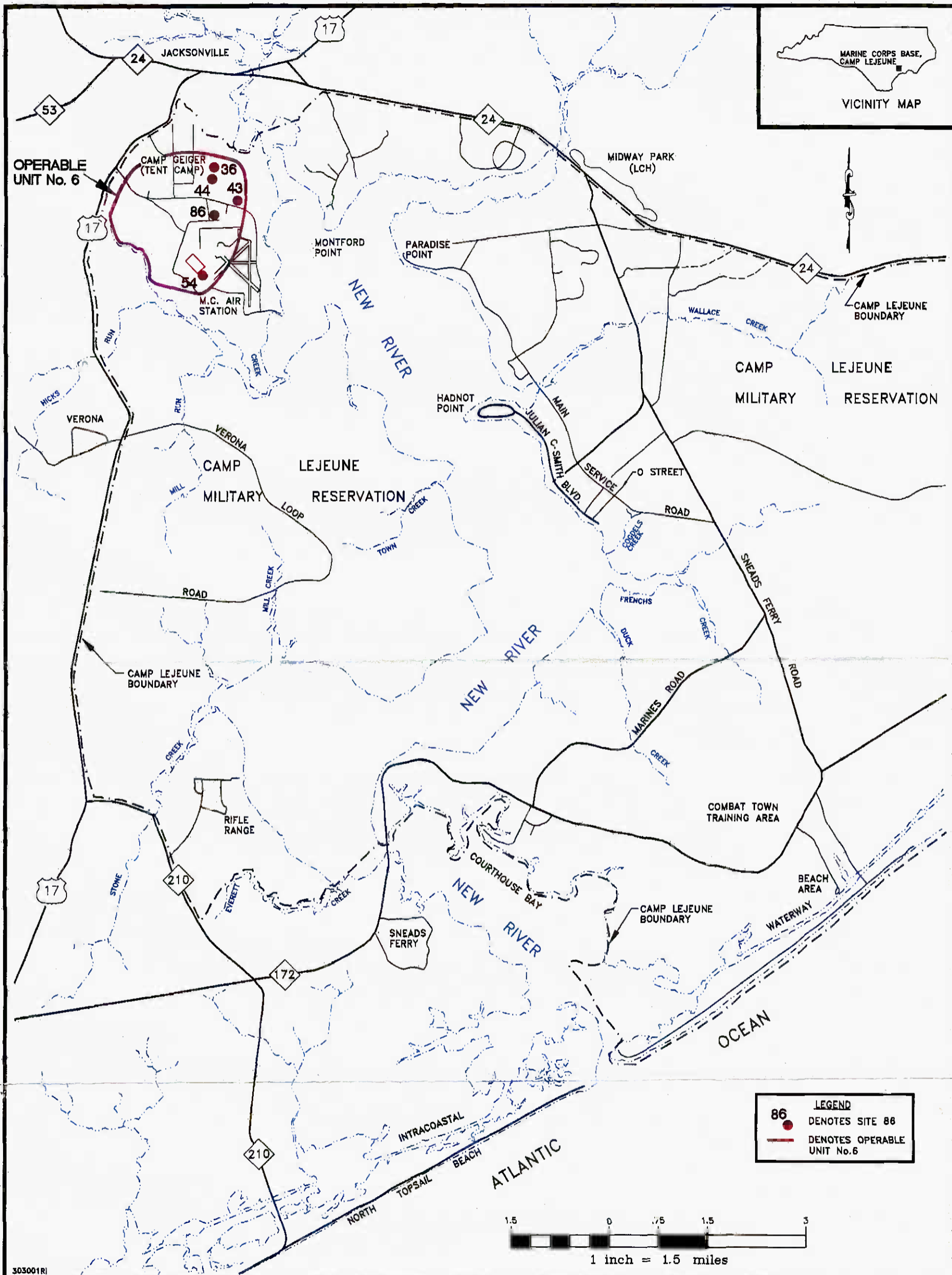


FIGURE 1-1
 OPERABLE UNIT No. 6 - SITES 36, 43, 44, 54, AND 86
 REMEDIAL INVESTIGATION, CTO-0303

MARINE CORPS AIR STATION, NEW RIVER
 NORTH CAROLINA

01719WB1Y

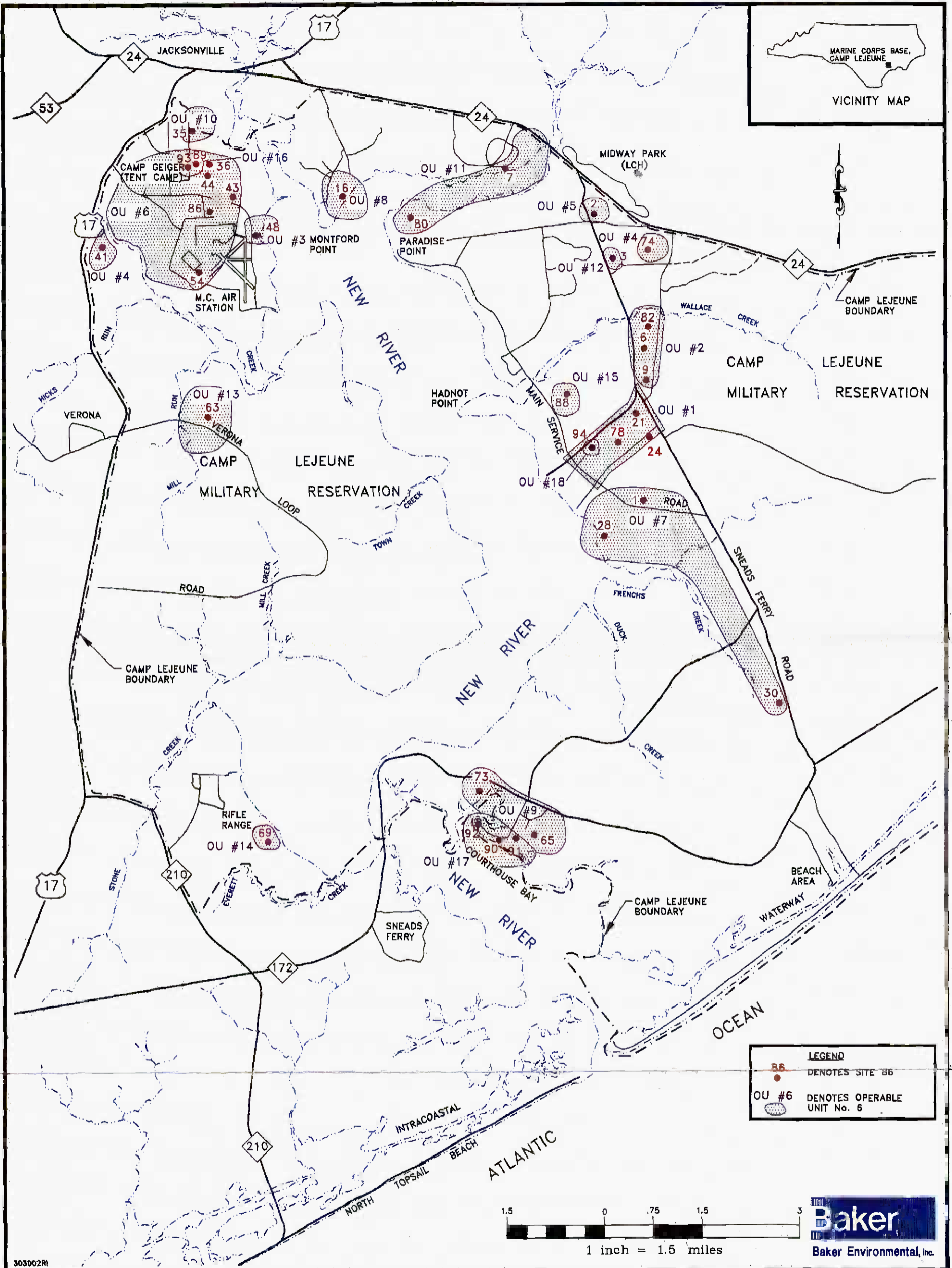
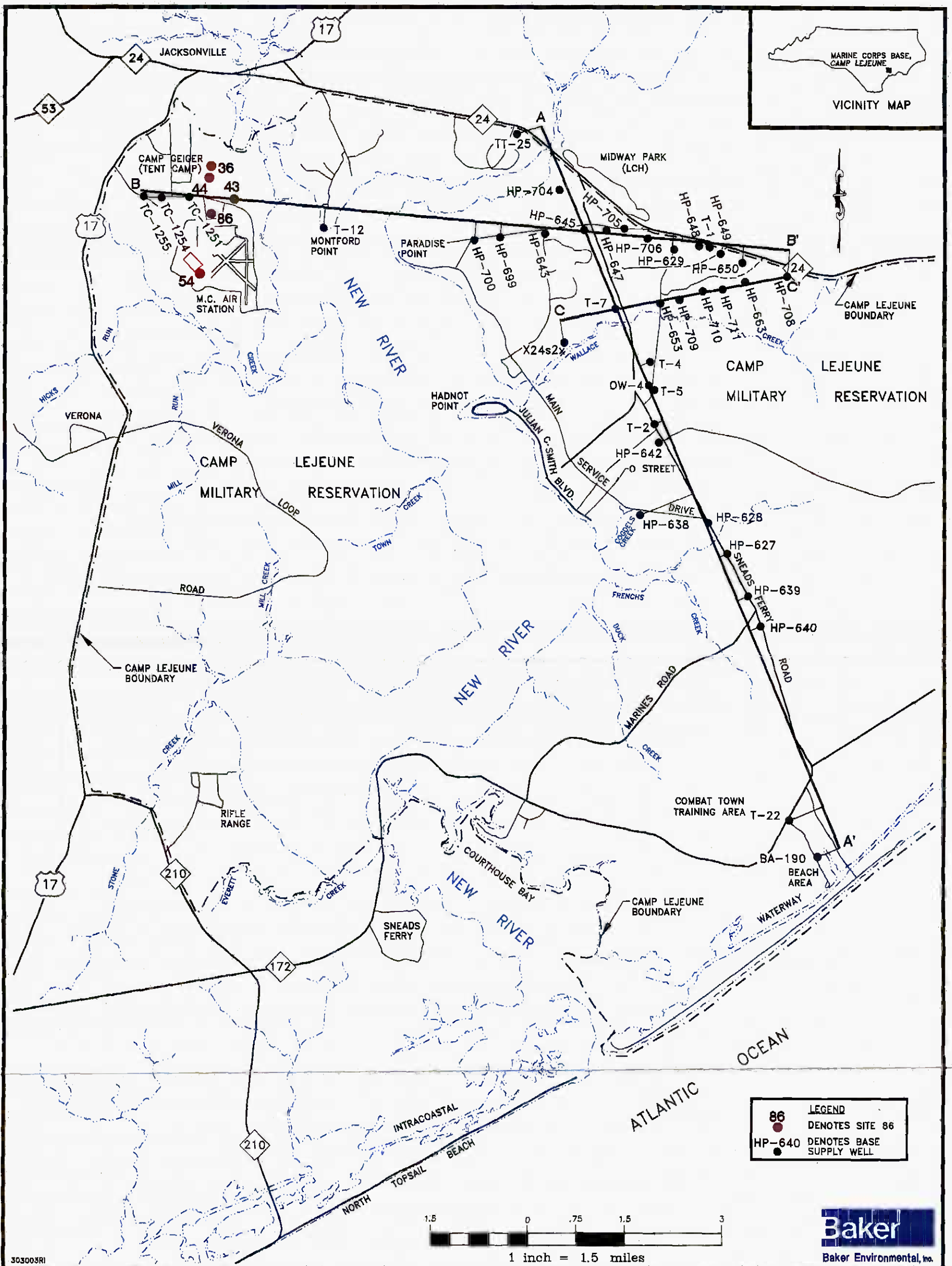


FIGURE 1-2
OPERABLE UNIT AND SITE LOCATIONS
REMEDIAL INVESTIGATION, CTO-0303

MARINE CORPS BASE, CAMP LEJEUNE
NORTH CAROLINA



303003R1

SOURCE: DEPT. OF INTERIOR,
WATER-RESOURCES INVESTIGATIONS
REPORT, 89-4098, PLATE 4

FIGURE 1-3
LOCATIONS OF HYDROGEOLOGIC CROSS-SECTIONS
REMEDIAL INVESTIGATION, CTO-0303

MARINE CORPS AIR STATION, NEW RIVER
NORTH CAROLINA

Baker
Baker Environmental, Inc.

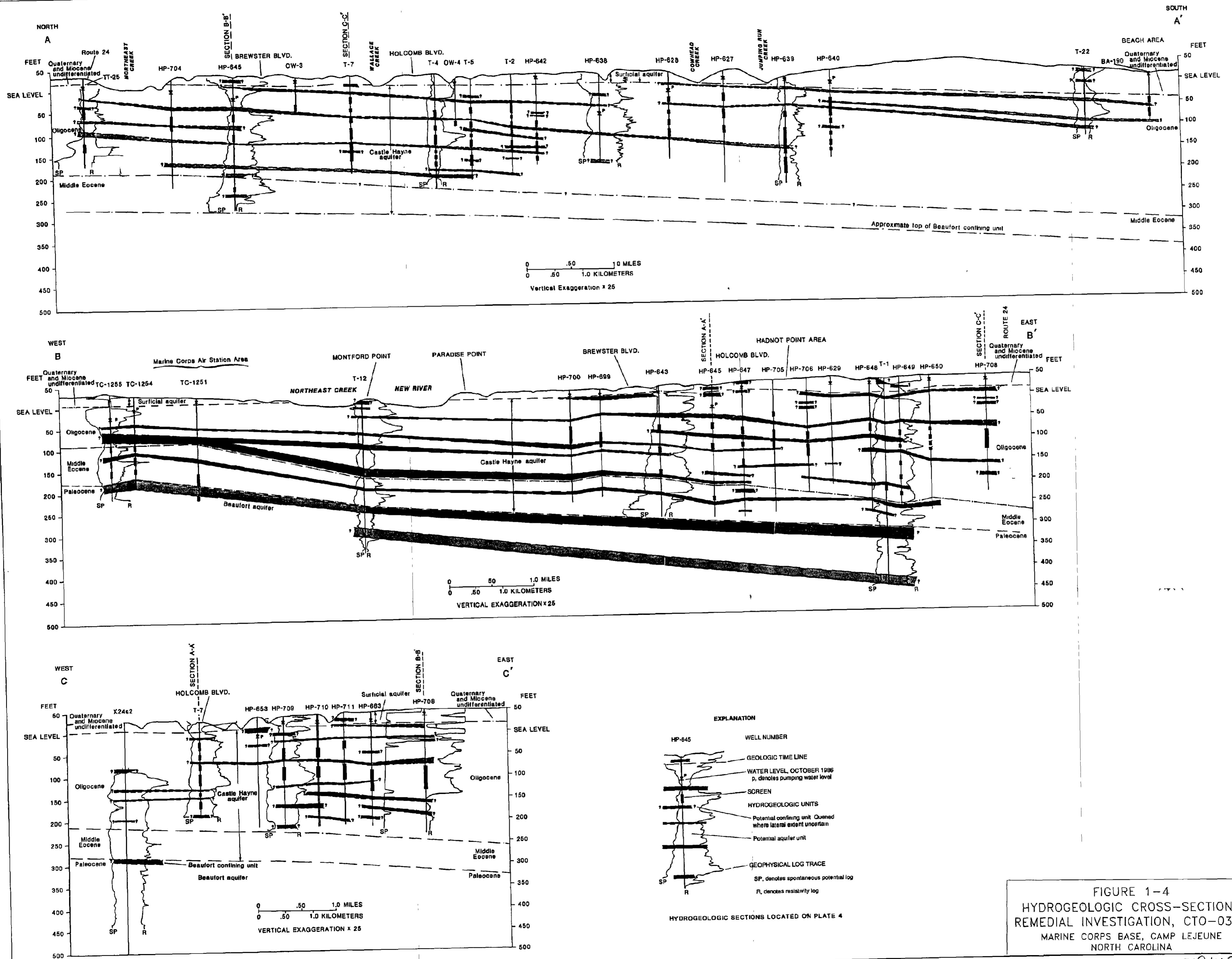
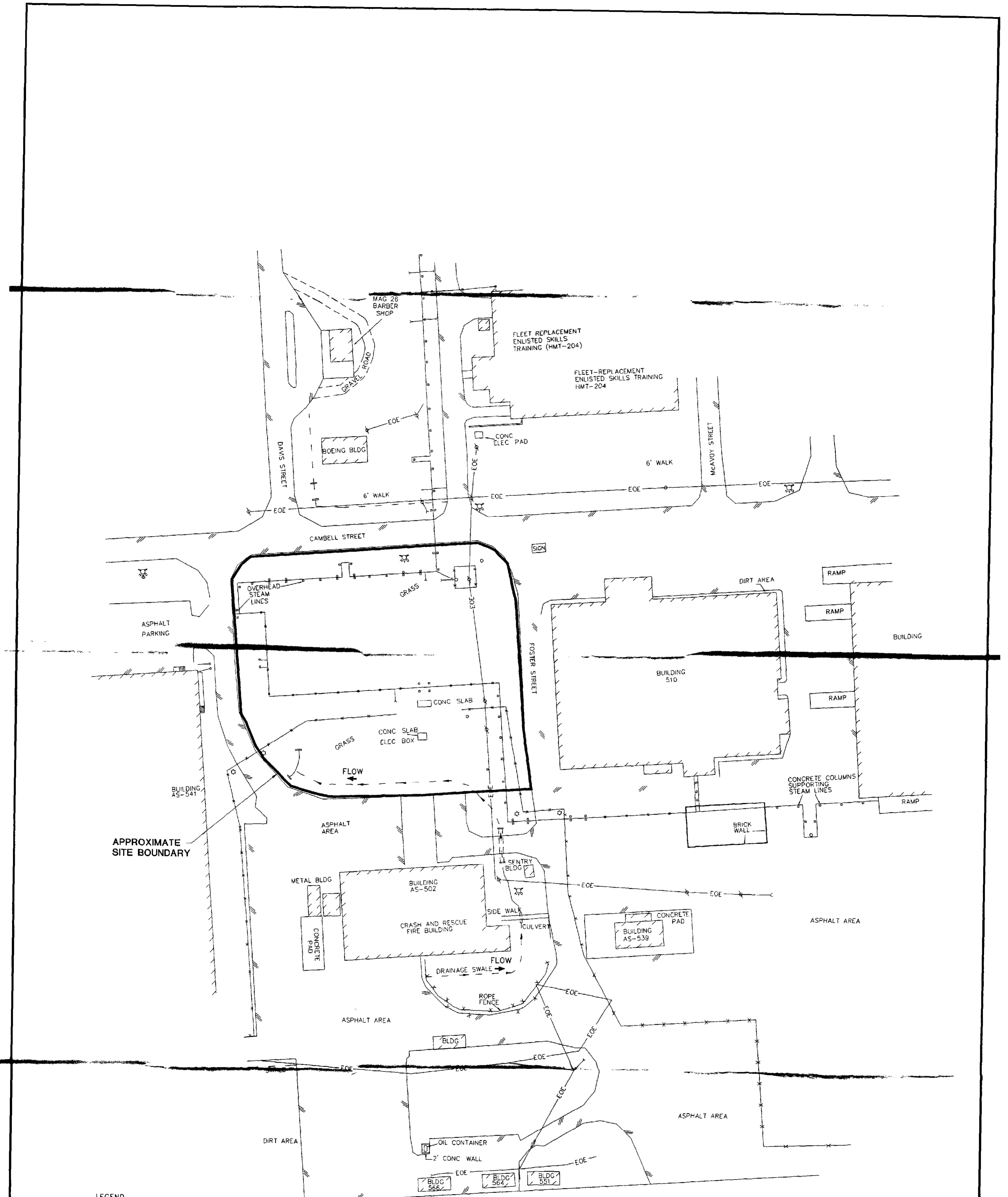


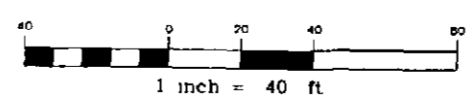
FIGURE 1-4
HYDROGEOLOGIC CROSS-SECTIONS
REMEDIAL INVESTIGATION, CTO-0303
MARINE CORPS BASE, CAMP LEJEUNE
NORTH CAROLINA

01719WB2X



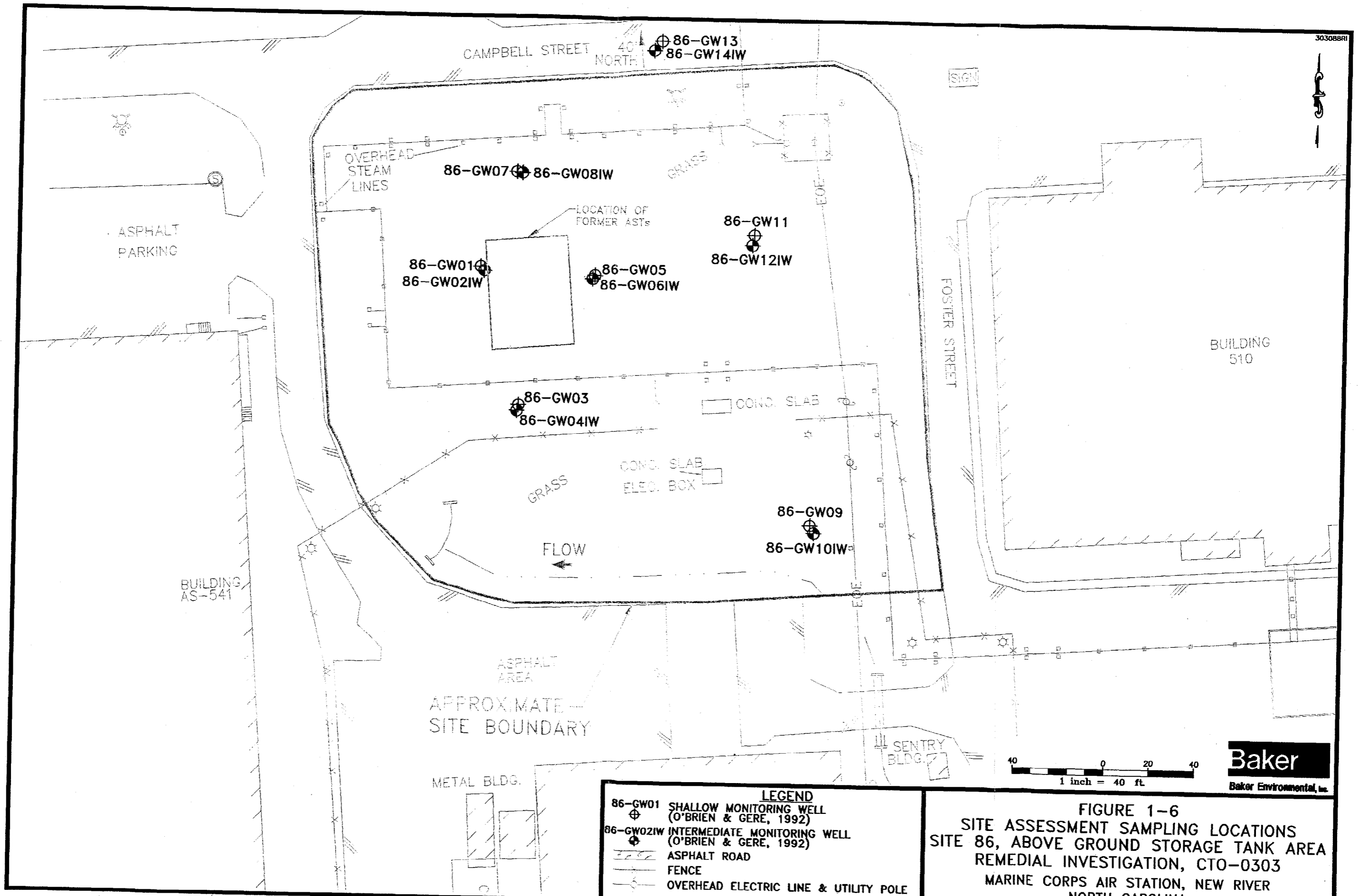
LEGEND

- DIRECTION OF SURFACE WATER FLOW
- OVERHEAD ELECTRIC LINE & UTILITY POLE
- FENCE
- ASPHALT ROAD
- GRAVEL ROAD
- CENTERLINE OF DRAINAGE SWALE
- LIGHTPOLE
- GUY WIRE
- FIRE HYDRANT
- STRUCTURE



<p>REVISIONS</p>	<p>DRAWN REL REVIEWED TFT S.O.# 62470-303 CADD# 30300BRI</p>	<p>NORTH</p>	<p>REMEDIAL INVESTIGATION CTO-0303 MARINE CORPS AIR STATION, NEW RIVER NORTH CAROLINA</p> <p>BAKER ENVIRONMENTAL, Inc Coraopolis, Pennsylvania</p>	<p>Baker Baker Environmental, Inc</p>	<p>SITE MAP SITE 86 ABOVE GROUND STORAGE TANK AREA</p> <p>SCALE: 1" = 40' DATE: JANUARY 1996</p>	<p>FIGURE No 1-5</p>
------------------	--	--------------	--	--	--	--------------------------

SOURCE: LANDIV FEBRUARY 1992
SURVEY: BRENT A. LANIER AND ASSOCIATES 1995



LEGEND

	86-GW01 SHALLOW MONITORING WELL (O'BRIEN & GERE, 1992)
	86-GW02IW INTERMEDIATE MONITORING WELL (O'BRIEN & GERE, 1992)
	ASPHALT ROAD
	FENCE
	OVERHEAD ELECTRIC LINE & UTILITY POLE

FIGURE 1-6
SITE ASSESSMENT SAMPLING LOCATIONS
SITE 86, ABOVE GROUND STORAGE TANK AREA
REMEDIAL INVESTIGATION, CTO-0303
MARINE CORPS AIR STATION, NEW RIVER
NORTH CAROLINA

01719W012

2.0 SITE CHARACTERISTICS

Section 2.0 of this report presents information on site-specific physical characteristics. This section includes a discussion on the topography, surface water hydrology, geology, hydrogeology, and ecology.

2.1 Topography and Surface Features

Site 86 is an approximately 250 feet by 130 feet grassy area within the heavily developed air station area. Site 86 is bounded by Campbell Street to the north, Foster Street to the east, the fire station fence to the south, and the fire station access road to the west. General surface topography is presented on Figure 2-1. Site 86 and vicinity is generally flat with surface elevations ranging from 15.5 to 18.0 feet above mean sea level (msl). Elevation within the site ranges from 16 to 17 feet msl. A gentle southwestern slope exists on the western portion of the site.

2.2 Surface Water Hydrology

Much of the area surrounding Site 86 is built-up with controlled drainage. Rain water on the streets, parking areas, and building roofs is collected by storm sewers. A drainage ditch is located west and south of the site, between the fire station access road and the site. Rain water that does not infiltrate into the ground at Site 86, will flow south and west to the drainage ditch. Water in the drainage ditch generally flows north, from the fire station. Water in this ditch flows underground through a culvert southwest of the site.

2.3 Soil

According to the Soil Conservation Service (SCS) Soil Survey of Camp Lejeune, North Carolina (1984), a single unit underlies Site 86. The Goldsboro Urban land complex (GpB) is associated with areas of alteration to the extent that the soil series is not easily recognized. Typically, this soil complex has been cut, filled, graded, or paved over. The physical properties of the soil have been altered through slope modification and smoothing to fit specific construction needs. GpB soils are very strongly acidic or strongly acidic unless the surface has been limed. GpB soils are classified by the SCS as SM, SM-SC (fine sandy loam), with slopes ranging from 0 to 5 percent. Table 2-1 provides a summary of soil physical properties found at Site 86.

2.4 Geology

A similar depositional sequence was encountered in borings throughout Site 86. The sequence generally matches the stratigraphic sequence discussed in the U.S. Geological Survey report prepared for MCB Camp Lejeune (Cardinell, et al., 1993) and shown on Figure 1-1. The uppermost formation at Site 86 is called the undifferentiated formation. The Belgrade Formation is absent at Site 86. Thus, the River Bend Formation lies immediately below the undifferentiated formation. The following discussion of subsurface lithologies includes Site 86 as wells as the surrounding area.

As discussed in Section 2.3 the soils have been disturbed through construction activities. Additionally, until recently three aboveground storage tanks (ASTs) were located at Site 86. It is evident through observations in some soil borings that the soils have been reworked. Non-native material, including rock and coal fragments, and concrete was observed in some shallow soil

borings, typically to a depth of 3 feet. Non-native material was observed to a depth of 9.5 feet and 7 feet, respectively in borings 86-AST-SB05 and 86-AST-SB06.

The uppermost formation at Site 86, the undifferentiated formation, consists of unconsolidated sediments of Holocene and Pleistocene ages. This formation typically extends to a depth between 25 to 35 feet below ground surface (bgs). A predominantly clay layer occurs at the surface south of the site and on the western portion of the site. A predominantly fine to medium sand layer occurs at the surface east of the site. Both the sand and clay layers are typically 5 to 15 feet thick, and tend to be thickest under Site 86. The clay layer tends to be soft to stiff, and the sand loose to medium dense. Below the sand and clay layers, is a predominantly fine to coarse sand layer. A fine sand replaces the medium sand west of the site. This fine to medium sand layer is typically 15 to 30 feet thick, and thickest south and southwest of the site. This sand layer tends to be loose to medium dense. A silty fine sand lies immediately below the fine to medium sand layer. This silty fine sand layer is typically 5 to 10 feet thick, and is very loose to loose. This layer is absent southwest of the site and in the Campbell Street area.

The River Bend Formation, which constitutes the uppermost unit of the Castle Hayne aquifer at the site, consists of several units of the Oligocene age. This formation lies 25 to 35 feet bgs at Site 86. The uppermost unit is a fossiliferous limestone 5 to 25 feet thick. The limestone consists of cemented and partially cemented shell fragments in a calcareous matrix of fine sand, silt, or clay. The limestone is typically medium dense to dense. A localized fine sand deposit of limited extent approximately 8 foot thick is present within the fossiliferous limestone formation and is typically medium dense to dense. A silty fine sand layer lies below the fossiliferous limestone. The silty fine sand layer is 35 to 45 feet thick and medium dense to very dense. A very stiff clay or silty clay layer was encountered below the silty fine sand, at a depth between 95 and 105 feet bgs.

Geologic cross-sections depicting the shallow and deep sediment lithologies were developed based on soils collected during the RI. Boring logs are provided in Appendix A and well boring construction logs are provided in Appendix B. Figure 2-1 shows the locations of the cross-sections traversing Site 86 and Figure 2-2 depicts the lithologies.

Cross-section A-A' traverses west to east through the northern portion of the site and typifies the sequence described above. The surficial clay in the undifferentiated formation extends nearly the entire length of the section but is replaced by a silty sand layer at the west end (86-GW17DW). Groundwater was encountered below or near the bottom of this clay layer. At 86-GW08IW, a wedge of relatively coarser-grained sand has replaced the finer-grained sands, including the silty fine sand layer at the bottom of the undifferentiated formation. The base of this unit has interpreted to be the contact between the surficial aquifer and the Castle Hayne aquifer. This section illustrates the River Bend sequence described above. The units of this formation gently dip to the east.

Cross-section B-B' traverses west to east along the southern portion of the site. This section shows a similar sequence as A-A', but a silty fine sand appears at the surface on either end of the section (86-GW18DW and 86-GW19DW). This section also indicates that the clay or silty clay layer from 95 to 105 feet bgs at 86-GW19DW is not continuous under the site. This unit was only encountered at one other location; 86-GW15DW (see cross-section D-D'). The base of the upper limestone unit

exhibits a slight synclinal-shaped dip. The fine sand and second limestone appear to dip slightly to the west.

Cross-section C-C' traverses north to south through the site. This section shows that the sandy clay layer found at 86-GW21IW and 86-GW10IW has been replaced by a fine to medium sand along the northern end of the section (86-GW14IW). Medium to coarse sands were observed in the undifferentiated formation along the northern end of this section. The upper limestone and fine sand units in the River Bend Formation appear fairly flat across this section. The second limestone unit is thin at 86-GW21IW, and the base of this unit appears to dip to the north.

Cross-section D-D' traverses northwest to southeast through the site. A clay/clay and silt layer is present at the surface across much of the section. A fine sand replaces the clay in the southeastern portion of the section at 86-GW19DW. Groundwater was encountered within the clay layer in this section. The upper limestone and fine sand units of the River Bend Formation appear relatively flat, although the upper limestone appears to thicken at 86-GW19DW. The base of the lower limestone unit appears to dip greatly to the southeast.

Cross-section E-E' traverses northeast to southwest through the site. Most of the borings in this section are relatively shallow, penetrating only the top of the River Bend Formation with the exception of 86-GW04IW. This section shows the clay, at the surface, within the middle of the section at 86-GW08 and 86-GW02.

Cross-section F-F' traverses northwest to southeast east of the site. This section shows both sand and clay at the surface. The clay layer observed at 86-GW16DW extends to a depth of approximately 7.5 feet bgs. This layer is absent at the northwest portion of the section (86-GW14IW) and thins southeastward toward 86-GW23IW where it has been partially replaced by fine sand at 86-GW23IW. Both limestone units of the River Bend Formation and the fine sand in between appear to dip slightly to the northwest. The upper limestone appears to thicken at 86-GW14IW.

2.5 Hydrogeology

There are several aquifers beneath Site 86 and vicinity. The uppermost two aquifers were investigated in this study; the surficial and Castle Hayne. The surficial aquifer, which is under unconfined conditions (i.e., water table aquifer), occurs within the sediments of the undifferentiated formation typically within 10 feet of the surface. The upper portion of the Castle Hayne aquifer occurs within the sediments of the River Bend Formation. The Belgrade Formation (Castle Hayne confining unit) is absent in the vicinity of the site. Sediments were observed to be saturated from the water table through boring completion. Thus, the surficial and Castle Hayne can be considered as one aquifer. According to Cardinell, the Castle Hayne aquifer is approximately 200 feet thick in the vicinity of Camp Geiger and the Air Station. Combining the Castle Hayne thickness with the surficial aquifer thickness, the total saturated thickness is then approximately 220 feet.

Hydrogeologic conditions were evaluated by installing a network of shallow, intermediate, and deep monitoring wells.

2.5.1 Groundwater Elevation Data

Groundwater elevation data for Site 86 are summarized on Table 2-2. Four rounds of groundwater level measurements were collected in March, April, May and August of 1995. Less than four rounds of water level data is available for some wells because of the installation timing.

Shallow monitoring wells (installed during previous investigations) are screened to intercept the water table at an average depth of approximately 15 feet bgs. Intermediate wells were installed at two depths, approximately 30 feet bgs and 55 to 60 feet bgs. Baker installed the "deeper" intermediate and deep wells as a part of this investigation. The intermediate wells are screened immediately above the Castle Hayne aquifer, and within the upper portion of the Castle Hayne aquifer. The deep wells are screened in the upper portion of the Castle Hayne aquifer; 90 to 110 feet bgs.

The groundwater elevation data in all wells exhibit a downward trend between March and May (Figure 2-3A through D). The decrease in elevation is approximately 1.5 feet. This data trend is likely attributable to a lack of precipitation during the time period. The groundwater elevation data in all wells exhibit an upward trend between May and August (Figure 2-3A through E). The increase is approximately 0.5 feet. This trend is likely attributable to frequent rain in July which, typically, receives the greatest amount of precipitation.

A comparison of groundwater elevation data at two well clusters, each with a shallow, an intermediate, and a deep well (Figure 2-3A) shows a consistent, decreasing elevation (head) with depth. This decreasing head indicates a downward flow component. This trend is also evident in comparisons of shallow/intermediate and intermediate/deep well clusters shown on Figures 2-3B, C, and D.

2.5.2 Groundwater Flow Contour Maps

Groundwater elevation contour maps were developed from static water level data collected between March and August of 1995. Shallow, intermediate, and deep groundwater flow patterns were similar for all four months. Since the patterns are similar, contour maps using only the May 1995 data are presented herein so that the maximum number of points could be used in a single point-in-time comparison. The contour maps are presented as Figures 2-4, 2-5, and 2-6 for the shallow, intermediate, and deep wells, respectively. Flow gradients were determined by dividing a certain distance of a flow line (or distance between two wells) into the change in groundwater elevation over that distance.

Shallow groundwater flow in the surficial aquifer is to the north across Site 86 (Figure 2-4). The groundwater flow gradient across the site is approximately 0.005 feet/foot to the north. The flow gradient varies little in the months data are available; from 0.004 feet/foot in March to 0.005 feet/foot in May. It appears that groundwater in the surficial aquifer flows toward Stick Creek, north of the site.

Despite the fact that the intermediate wells are screened at two different depths, groundwater elevations are similar and can be mapped together (Figure 2-5). Groundwater flow in the lower portion of the surficial aquifer and upper portion of the Castle Hayne aquifer is generally to the northeast. The flow gradient is approximately 0.003 feet/foot to the northeast. It appears that groundwater in the lower surficial aquifer flows toward the New River. The flow gradient varies

little in the months data are available, from 0.003 feet/foot in April, May and August to 0.004 feet/foot in March.

Groundwater flow in the Castle Hayne aquifer (as measured by the deep wells) is to the east-northeast across the site (Figure 2-6). The flow gradient is approximately 0.003 ft/ft. The flow gradient varies little in the months data are available; from 0.003 feet/foot in May to 0.005 feet/foot in March. It appears that groundwater in the Castle Hayne aquifer flows toward the New River. A review of the groundwater elevations presented on Figures 2-5 and 2-6 are nearly identical across the site. This observation is further evidence of the interconnection between aquifers.

Vertical groundwater flow gradients were determined by dividing the distance between two well screen midpoints in a given cluster into the change in the groundwater elevation. Vertical gradients ranged from 0.001 feet/foot at wells 86-GW03/04 to 0.05 feet/foot at wells 86-GW11/12 (Appendix O).

2.5.3 Hydraulic Properties

Rising and falling head slug tests were conducted at Site 86 on several shallow, intermediate, and deep monitoring wells during the field program. The slug test data were analyzed using the Bower-Rice method on AQTESOLV Version 2.0 software. The solutions are presented in Appendix M and are summarized on Table 2-3.

Rising head test data is used in the text discussions. Falling head test data was used where available as a check against the rising head data. The falling head test is equally valid to the rising head when the static water level is above the screen interval. The static water level in several wells was within the screened interval. These falling head data sets were not analyzed.

Geotechnical analyses, including particle size analysis and vertical hydraulic conductivity was determined for a subsurface soil sample collected via shelly-tube (Appendix L). The sample was collected from the undifferentiated formation at the 67 to 69 feet bgs interval from well boring 86-GW16DW. This sample was collected below the second limestone layer and was determined to be a clayey fine sand with a vertical permeability of 0.001 feet/day (4.4×10^{-7} cm/sec). The vertical permeability suggests that flow is very slow through this zone at 86-GW16DW.

The sediments of the surficial and Castle Hayne aquifers vary in composition. The slug test results also vary. The hydraulic conductivities of the surficial aquifer ranged from 0.2 feet/day (86-GW11) to 7.7 feet/day (86-GW03). The hydraulic conductivities of the Castle Hayne aquifer ranged from 0.2 feet/day (86-GW15DW) to 11.1 feet/day (86-GW20DW). Well 86-GW20IW exhibits the highest hydraulic conductivity of all wells; 11.1 feet/day. This well is screened mostly in limestone and shell fragments. Wells 86-GW11 and 86-GW15DW exhibited the lowest hydraulic conductivity of all wells; 0.2 feet/day. Well 86-GW11 is screened in sandy clay and medium sand while 86-GW15DW in a silty sand.

Transmissivities vary because of varying hydraulic conductivity values (Table 2-3). Transmissivity is the hydraulic conductivity multiplied by the saturated thickness of the aquifer. Because the surficial and Castle Hayne aquifers are not separated by a confining unit, one thickness value was used (220 feet). Transmissivity values in the shallow wells ranged from 44 ft²/day at 86-GW11 to 1,694 ft²/day at 86-GW05 with an average of 623.3 ft²/day. Transmissivities in the intermediate

and deep wells range from 44 ft²/day at 86-GW15DW to 2,442 ft²/day at 86-GW20IW, with an average of 757.4 ft²/day.

The average surficial aquifer hydraulic conductivity value calculated during this study is an order of magnitude lower than the value presented by Cardinell. The average hydraulic conductivity value at Site 86, based on RI slug tests is 2.8 feet/day (shallow wells), compared to 50 feet/day presented in Cardinell. The Cardinell value was estimated based on grain size; a general composition of fine sand, mixed with some silt and clay. The average hydraulic conductivity and transmissivity for the Castle Hayne (intermediate and deep) at Site 86 is 3.4 feet/day and 757 feet²/day, respectively. Cardinell reported hydraulic conductivities and transmissivities from several studies. Hydraulic conductivities ranged from 14 to 91 feet/day, and transmissivities range from 820 to 26,000 feet²/day. The RI results at Site 86 tend to less than the range from other sites throughout MCB Camp Lejeune. The differences may be attributable to several factors. Most of the Site 86 wells are screened in less conductive silty fine sand layers of the Castle Hayne aquifer, while supply wells would likely be screened in more productive zones. Different test methodologies would produce different results (e.g., slug test verses pumping tests). Additionally, the Cardinell data encompassed several sites over a larger area than Site 86.

2.5.4 Groundwater Flow Velocities

Groundwater flow velocities can be estimated using a variation of Darcy's equations:

$$V = Ki/n_e$$

where;

- V = groundwater velocity (feet/day)
- K = Hydraulic conductivity (feet/day)
- i = horizontal gradient (feet/foot)
- n_e = effective porosity

Hydraulic conductivity values were determined from slug tests conducted at ten wells (Table 2-3). Surficial aquifer hydraulic conductivity values ranged from 0.2 ft/day at 86-GW11 to 7.7 ft/day at 86-GW05. Castle Hayne aquifer hydraulic conductivity values ranged from 0.2 ft/day at 86-GW15DW to 11.1 ft/day at 86-GW20IW. Flow gradient values were determined by using groundwater contours (Section 2.5.3). An effective porosity value of 30% was used (estimated from Fetter, 1988), based on a silty sand composition. Groundwater velocity calculations are provided in Appendix N.

For the surficial aquifer, calculated groundwater flow velocities varied by two orders of magnitude, ranging from 0.003 feet/day to 0.13 feet/day. For the Castle Hayne aquifer, calculated groundwater flow velocities also varied by two orders of magnitude, ranging from 0.002 feet/day to 0.11 feet/day. The varying velocities are attributable to the varying hydraulic conductivities.

2.5.5 General Groundwater Flow Patterns

Local and regional groundwater flow patterns were observed at Site 86. Local flow; flow within the surficial aquifer is toward Stick Creek, with an average velocity of 0.05 feet/day. Surficial aquifer groundwater likely discharges to Stick Creek, based on groundwater flow direction and elevation relative to the creek. Regional flow within the lower surficial and upper Castle Hayne aquifers flows toward the New River with an average velocity of 0.03 feet/day. It is likely that groundwater in the

Castle Hayne aquifer discharges to the New River. This observation is supported by groundwater elevation data compiled and mapped by Cardinell which indicates that groundwater in the Castle Hayne aquifer flows toward, and discharges to the New River and its major tributaries.

There appears to be a hydraulic connection between the surficial and Castle Hayne aquifers. The Castle Hayne confining unit was observed to be absent in the vicinity of Site 86. Additionally, the well cluster groundwater elevation data exhibit a downward flow component that is typical for groundwater recharge areas. This is consistent with Cardinell, who indicates that groundwater recharge occurs in interstream areas, like the Site 86 area.

2.6 Identification of Water Supply Wells

Potable water supply wells within a one-mile radius of the site were identified by reviewing the Wellhead Management Program Engineering Study (Geophex, Ltd., 1991). Seven water supply wells were identified within the one-mile radius. Five of the wells were reported to be operating. Table 2-4 summarizes some well construction details and Figure 2-7 shows the location of the supply wells. These supply wells are located upgradient of Site 86 based on their location with respect to northeasterly groundwater flow in the Castle Hayne aquifer under Site 86. Additionally, it appears that these supply wells have not altered groundwater flow at Site 86 based on the groundwater flow patterns.

Five of the seven supply wells were sampled in 1992 (Greenhorne & O'Mara, 1992). Detected compounds are presented on Table 2-4. No organic compounds were detected in any of the wells listed. Several inorganic analytes were detected. The USEPA and North Carolina have established Secondary Maximum Concentration Limits (SMCLs) and Standards, respectively, for several of the detected analytes. The Aluminum SMCL was exceeded in all wells sampled, except MCAS-131. The iron, manganese, and TDS Standards/SMCLs were exceeded in several wells.

Aluminum and iron appear to be ubiquitous at Camp Lejeune at relatively high levels. These metals have been detected in supply wells throughout Camp Lejeune, and in monitoring wells at other OU 6 sites.

2.7 Ecology

No wetlands are present at Site 86. No sensitive environments were identified at any of the sites studied during this remedial investigation. No endangered species were noted during the habitat evaluation nor were endangered species referenced at any of the sites during the endangered species survey (LeBlond, 1994).

Site 86 is an open industrial surrounded by buildings, utility lines, and roads. Figure 2-8 shows a habitat map of the Site 86 area. The site is covered by mowed lawn and the only trees present are several ornamentals-- loblolly pine (*Pinus taeda*), water oak (*Quercus nigra*), and crape myrtle. Grass is dominant in most areas of the site, although large patches of white clover (*Trifolium repens*) are also found. These plants are mixed with a variety of herbaceous annuals and perennials including the following:

- Dandelion- *Taraxacum officinale*
- Mouse-ear Chickweed- *Cerastium vulgatum*
- Thyme-leaved Speedwell- *Veronica serpyllifolia*

- Queen Anne's Lace- Daucus carota
- Black Medic- Medicago lupulina
- Quaker Ladies- Houstonia caerulea
- Yellow Wood Sorrel- Oxalis europaea
- Cow Vetch- Vicia cracca
- Fleabane- Erigeron sp.
- Pennsylvania Bittercress- Cardamine pensylvanica
- Creeping Buttercup- Ranunculus repens
- Narrow-leaved Plantain- Plantago lanceolata
- Wild Onion- Allium vineale
- Curly Dock- Rumex crispus
- Thistle- Cirsium sp.
- Wild Pansy- Viola kitaibeliana
- Carolina Cranesbill- Geranium carolinianum
- Moneywort- Lysmachia nummularia

Only two species of birds, house sparrow (Passer domesticus) and fish crow (Corvus ossifragus), were observed at the site. The house sparrows were nesting in nearby buildings. No mammal, reptiles, or amphibians were noted at the site during the habitat evaluation, nor were signs of any of these animals observed.

2.8 References

Barnhill, W.L. 1984. Soil Survey of Camp Lejeune, North Carolina. USDA, Soil Conservation Service.

Cardinell, A.P., Berg, S.A., and Lloyd O.B. Jr. 1993. Hydrogeologic Framework of U.S. Marine Corps Base at Camp Lejeune, North Carolina. USGS. Water-Resources Investigations Report 93-4049.

Fetter, C.W. 1986. Applied Hydrogeology. Charles E. Merrill Publishing Co., Columbus, Ohio.

Geophex, Ltd. 1992. Wellhead Management Program Engineering Study 91-36. Prepared for Marine Corps Base, Camp Lejeune, North Carolina. January 22, 1992.

Greenhorne & O'Mara. 1992. Preliminary Draft Report Wellhead Monitoring Study. Prepared for the Department of the Navy, Civil Branch. December, 1992.

Harned, D.A., Lloyd, O.B., Jr., and Treece, M.W., Jr. 1989. Assessment of Hydrologic and Hydrogeologic Data at Camp Lejeune Marine Corps Base, North Carolina. USGS. Water-Resources Investigations Report 89-4096.

LeBlond, Richard. 1991. Critical Species List - Camp Lejeune Endangered Species and Special-Interest Communities Survey. Principal Investigator.

SECTION 2.0 TABLES

TABLE 2-1

SUMMARY OF SOIL PHYSICAL PROPERTIES AT SITE 86
 REMEDIAL INVESTIGATION CTO - 0303
 MCB, CAMP LEJEUNE, NORTH CAROLINA

Soil Name	Soil Symbol	USCS Classification	Depth (inches)	Moist Bulk Density (g/cc)	Permeability (cm/s)	Soil Reaction (pH)	Shrink-Swell Potential	Organic Matter (percent)
Goldsboro-Urban	GpB	SM, SM-SC	0 - 13	1.40 - 1.60	1.4×10^{-3} - 4.2×10^{-3}	4.5 - 6.0	Low	0.5 - 2.0

Source: Soil Survey: Camp Lejeune, North Carolina, U. S. Department of Agriculture - Soil Conservation Service, 1984.

- Notes:
- ML - Loam
 - SM - Loamy Fine Sand
 - SP - Fine Sand
 - - Not Estimated
 - SC - Fine Sandy Loam

TABLE 2-2

SUMMARY OF GROUNDWATER ELEVATIONS
 SITE 86
 REMEDIAL INVESTIGATION CTO-0303
 MCAS, NEW RIVER, NORTH CAROLINA

Well No.	Casing Elevation	Static Water Levels (TOC)				Groundwater Elevations			
		3/28/95	4/10/95	5/10/95	8/18/95	3/28/95	4/10/95	5/10/95	8/18/95
86-GW01	19.39	7.82	8.39	9.36	8.92	11.57	11.00	10.03	10.47
86-GW03	18.20	6.60	7.17	8.13	7.66	11.60	11.03	10.07	10.54
86-GW05	19.43	8.01	8.55	9.52	NA	11.42	10.88	9.91	NA
86-GW07	20.14	8.72	9.25	10.21	9.76	11.42	10.89	9.93	10.38
86-GW09	18.50	7.20	7.72	8.64	8.20	11.30	10.78	9.86	10.30
86-GW11	19.81	8.32	8.89	9.82	9.36	11.49	10.92	9.99	10.45
86-GW13	16.88	5.96	6.56	7.60	7.12	10.92	10.32	9.28	9.76
86-GW02IW	18.86	7.40	7.92	8.89	8.49	11.46	10.94	9.97	10.37
86-GW04IW	18.16	6.70	7.20	8.11	7.72	11.46	10.96	10.05	10.44
86-GW06IW	19.21	7.88	8.38	9.33	8.90	11.33	10.83	9.88	10.31
86-GW08IW	19.92	8.68	9.17	10.11	9.70	11.24	10.75	9.81	10.22
86-GW10IW	17.95	6.72	7.26	8.15	7.78	11.23	10.69	9.80	10.17
86-GW12IW	18.74	7.70	8.19	9.14	8.70	11.04	10.55	9.60	10.04
86-GW14IW	16.91	6.18	6.66	7.63	NA	10.73	10.25	9.28	NA
86-GW15IW	16.56	5.72	6.21	7.08	6.72	10.84	10.35	9.48	9.84
86-GW16IW	16.71	6.38	6.82	7.79	7.38	10.33	9.89	8.92	9.33
86-GW17IW	17.03	5.42	5.92	6.88	6.51	11.61	11.11	10.15	10.52
86-GW20IW	17.87	NA	7.10	8.01	7.62	NA	10.77	9.86	10.25
86-GW21IW	18.22	NA	NA	7.92	7.68	NA	NA	10.30	10.54
86-GW22IW	17.78	NA	NA	8.27	7.93	NA	NA	9.51	9.85
86-GW23IW	17.36	NA	NA	8.57	8.19	NA	NA	8.79	9.17
86-GW15DW	16.49	5.80	6.27	7.14	6.82	10.69	10.22	9.35	9.67
86-GW16DW	16.82	6.60	7.05	7.79	7.60	10.22	9.77	9.03	9.22
86-GW17DW	17.24	5.71	6.19	7.13	6.80	11.53	11.05	10.11	10.44
86-GW18DW	17.89	6.51	7.00	7.92	7.60	11.38	10.89	9.97	10.29
86-GW19DW	18.67	7.66	8.17	9.07	8.72	11.01	10.50	9.60	9.95

TABLE 2-3

**HYDRAULIC PROPERTIES SUMMARY
SITE 86
REMEDIAL INVESTIGATION CTO - 0303
MCAS, NEW RIVER, NORTH CAROLINA**

Well ID	Conductivity		Transmissivity		Conductivity		Transmissivity		General Soil Description
	Rising Head (ft/day)	Falling Head (ft/day)	Rising Head (ft ² /day)	Falling Head (ft ² /day)	Rising Head (cm/day)	Falling Head (cm/day)	Rising Head (cm ² /day)	Falling Head (cm ² /day)	
86-GW01	0.6	--	132.0	--	2.12e-04	--	1.4	--	M/C sand with silt & clay
86-GW05	7.7	--	1,694.0	--	2.72e-03	--	18.2	--	M/C sand with silt & clay
86-GW11	0.2	--	44.0	--	7.06e-05	--	0.5	--	F sand, w/ sandy clay layer
MAXIMUM	7.7	--	1,694.0	--	2.72e-03	--	18.2	--	
MINIMUM	0.2	--	44.0	--	7.06e-05	--	0.5	--	
AVERAGE	2.8	--	623.3	--	1.00e-03	--	6.7	--	
86-GW15IW	1.8	3.1	396.0	620.0	6.35e-04	1.09e-03	3.9	6.7	F sand, little silt & fossil. limestone layers
86-GW16IW	3.8	4.1	836.0	820.0	1.34e-03	1.45e-03	8.2	8.8	F sand, little silt & fossil. limestone layers
86-GW17IW	1.1	0.3	242.0	60.0	3.88e-04	1.06e-04	2.4	0.6	F sand, little silt & fossil. limestone layers
86-GW20IW	11.1	8.4	2,442.0	1,680.0	3.92e-03	2.97e-03	23.9	18.1	Fossil. limestone
86-GW15DW	0.2	0.3	44.0	60.0	7.06e-05	1.06e-04	0.4	0.6	Silty sand, trace clay
86-GW18DW	4.2	3.8	924.0	760.0	1.48e-03	1.34e-03	9.0	8.2	F sand, trace silt & shell frag.
86-GW19DW	1.9	1.9	418.0	380.0	6.71e-04	6.71e-04	4.1	4.1	Silty sand, trace clay & shell frag.
MAXIMUM	11.1	8.4	2442	1680	3.92e-03	2.97e-03	23.9	18.1	
MINIMUM	0.2	0.3	44	60	7.06e-05	1.06e-04	0.4	0.6	
AVERAGE	3.4	3.1	757.4	625.7	1.22e-03	1.10e-03	7.4	6.7	

Notes:

"--" Falling head slug test not performed as well level was within screened interval.

Transmissivity calculation assumed a combined 220 ft thickness for surficial and Castle Hayne aquifers.

TABLE 2-4

**SUMMARY OF POTABLE WATER SUPPLY WELLS
WITHIN A ONE-MILE RADIUS OF SITE 86
REMEDIAL INVESTIGATION CTO-0303
MCAS, NEW RIVER, NORTH CAROLINA**

Supply Well Number	Well Depth (ft)	Screened Interval (ft)	Well Dia. (in)	Approx. Dist.and Dir.	Status of Well	Al (µg/L)	Cu (µg/L)	Fe (µg/L)	Pb (µg/L)	Mn (µg/L)	Zn (µg/L)	Chloride (µg/L)	Fluoride (µg/L)	Nitrite (µg/L)	Sulfate (µg/L)	TDS (µg/L)
TC-1251	240	120-140	NA	4,300ft/NW	On	260 (5)	ND (2)	490 (4)	ND	120 (4)	ND	170,000	500	30	6,000	660,000 (4)
MCAS-106	NA (1)	NA	NA	4,000ft/SSW	Off	NA	NA	NA	NA	NA	NA	NA	NA	NA	NA	NA
MCAS-203	173	NA	NA	4,000ft/SSW	On	360 (5)	ND	470 (4)	ND	ND	ND	180,000	1,400	ND	22,000	760,000 (4)
MCAS-131	200	NA	NA	5,000ft/SSW	On	ND	60	540 (4)	7	50	20	110,000	400	50	28,000	550,000 (4)
TC-191(3)	180	130-140	NA	5,100ft/W	On	270	ND	70	ND	ND	ND	260,000	500	20	13,000	560,000 (4)
MCAS-4140	NA	NA	NA	3,700ft/NNW	On	300	180	180	ND	ND	ND	140,000	300	ND	10,000	620,000 (4)

Notes:

The analytical data presented in this table represent detected analytes.

(1) Status not available

(2) Not available

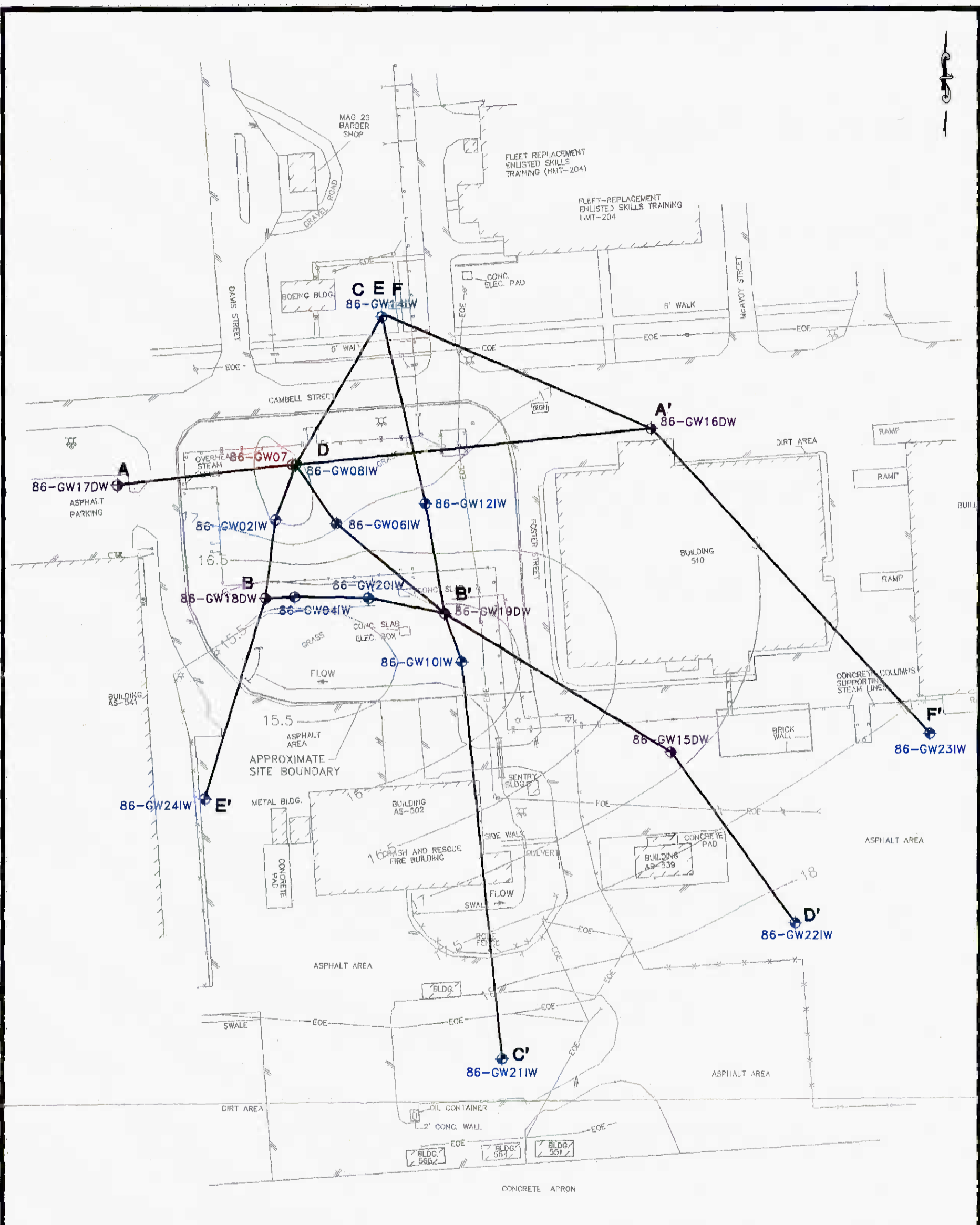
(3) TC-191 also designated as AS-191.

(4) Above USEPA & NC SMCL/Standard (Fe=300 µg/L, Mn=50 µg/L, TDS=500,000 µg/L)

(5) Above USEPA SMCL (Al=200 µg/L)

See Figure 2-7 for well locations.

SECTION 2.0 FIGURES



303101R1

LEGEND

- 86-GW01 SHALLOW MONITORING WELL
- 86-GW04IW INTERMEDIATE MONITORING WELL
- 86-GW18DW DEEP MONITORING WELL
- A-A' CROSS SECTION TRAVERSE
- FLOW DIRECTION OF SURFACE WATER FLOW
- EOE OVERHEAD ELECTRIC LINE & UTILITY POLE
- ASPHALT ROAD
- CENTERLINE OF DRAINAGE SWALE
- LIGHTPOLE
- STRUCTURE
- GRAVEL ROAD
- FENCE
- GUY WIRE
- FIRE HYDRANT

SOURCE: LANTDIV. OCT. 1991

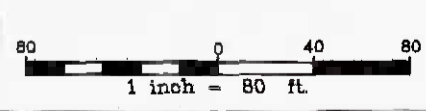
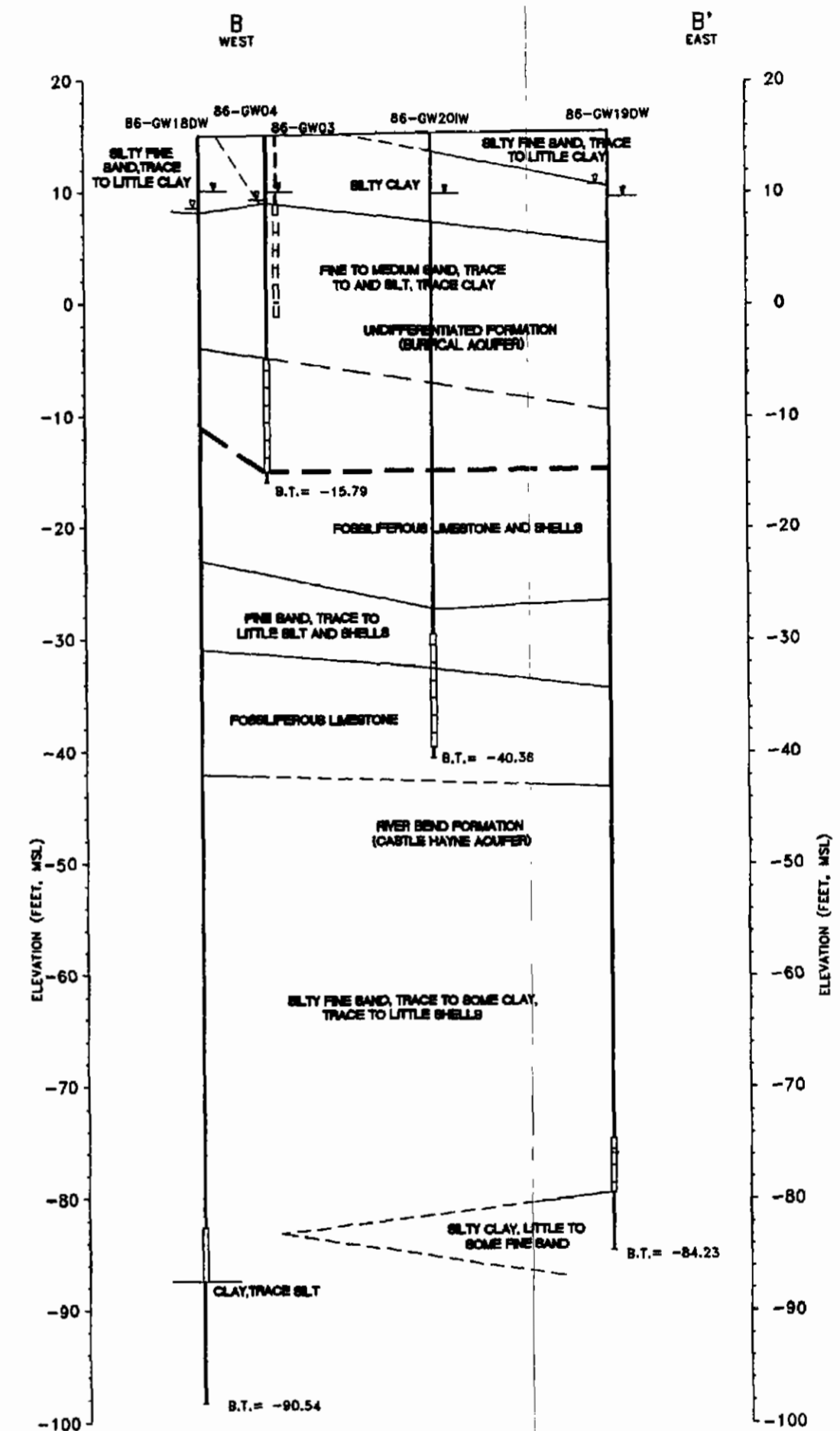
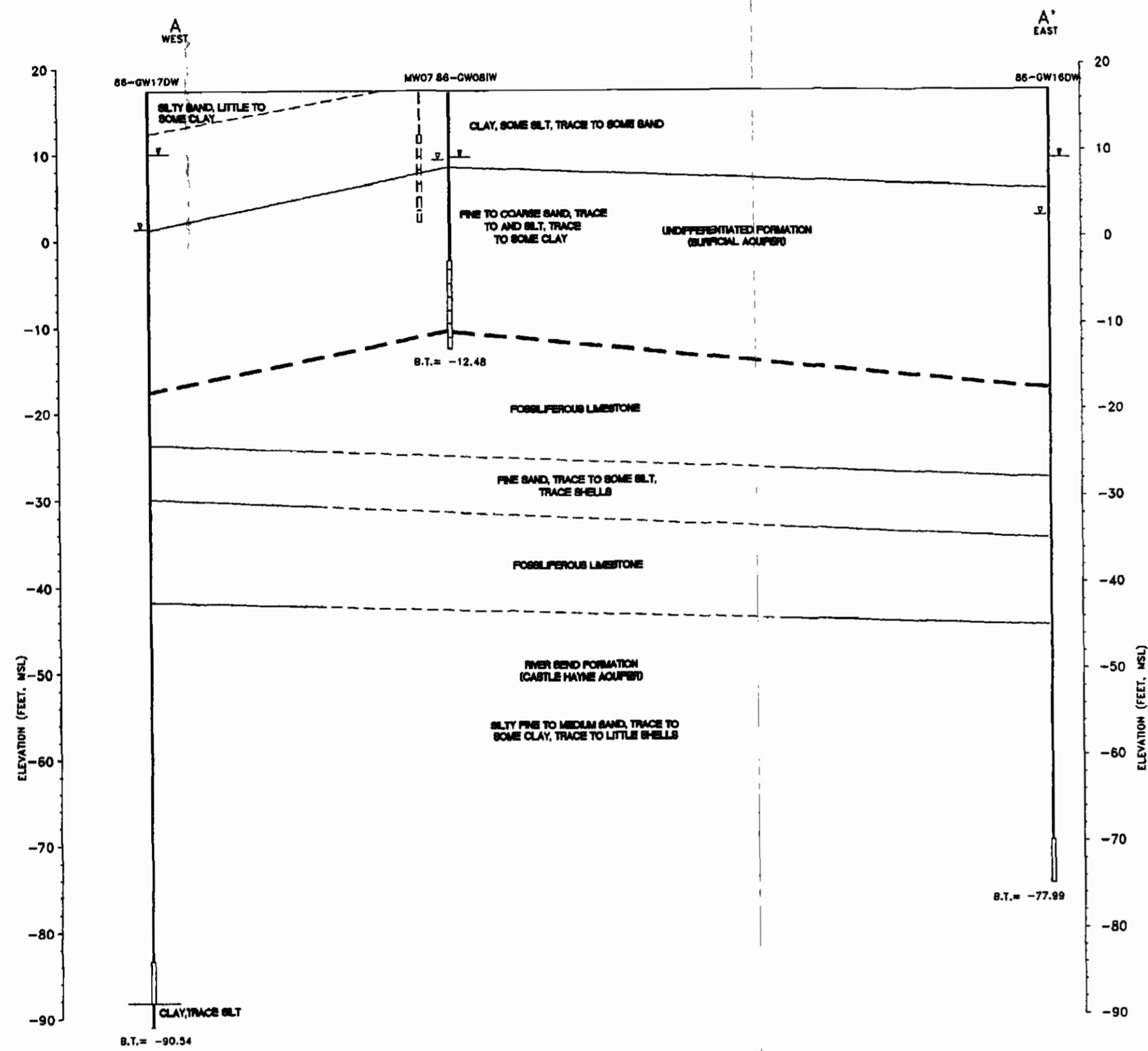
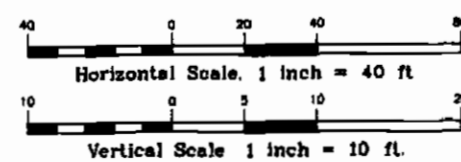


FIGURE 2-1
CROSS SECTION LOCATION AND APPROXIMATE SURFACE ELEVATION CONTOUR MAP
SITE 86, ABOVE GROUND STORAGE TANK AREA
REMEDIAL INVESTIGATION, CTO-0303
MARINE CORPS AIR STATION, NEW RIVER
CAMP LEJEUNE

019191012V

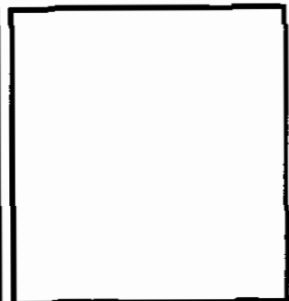
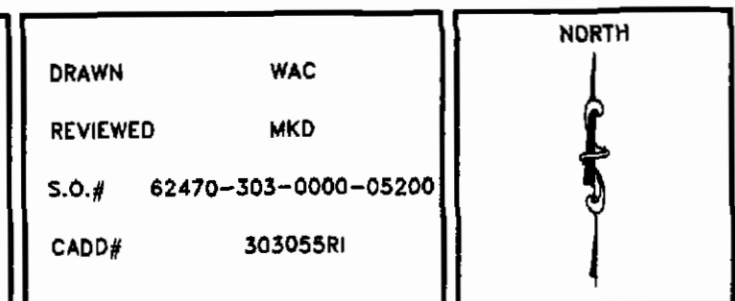


- LEGEND**
- I- STATIC WATER LEVEL (MAY 10, 1995)
 - I- GROUNDWATER ENCOUNTERED IN SOIL BORING TERMINATED, ELEVATION MSL
 - B.T. -10.0 WELL SCREEN INTERVAL
 - ESTIMATED
 - PROJECTED
 - FORMATION CONTACT



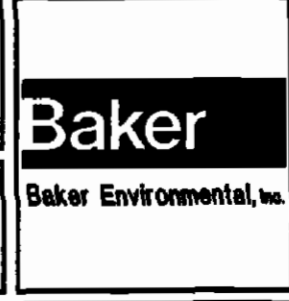
NOTES:
 -DASHED WELL SYMBOL INDICATES THAT SHALLOW WELL LOG WAS USED TO CONFIRM LITHOLOGIES PRESENTED IN INTERMEDIATE WELL LOGS.
 -THE SOIL BORING INFORMATION IS CONSIDERED TO BE REPRESENTATIVE OF SUBSURFACE CONDITIONS AT THE RESPECTIVE BORING LOCATIONS. SUBSURFACE CONDITIONS INTERPOLATED BETWEEN BORINGS ARE ESTIMATED BASED ON ACCEPTED SOIL ENGINEERING PRINCIPLES AND GEOLOGIC JUDGMENT.

REVISIONS	
DRAWN	WAC
REVIEWED	MKD
S.O.#	62470-303-0000-05200
CADD#	303055RI



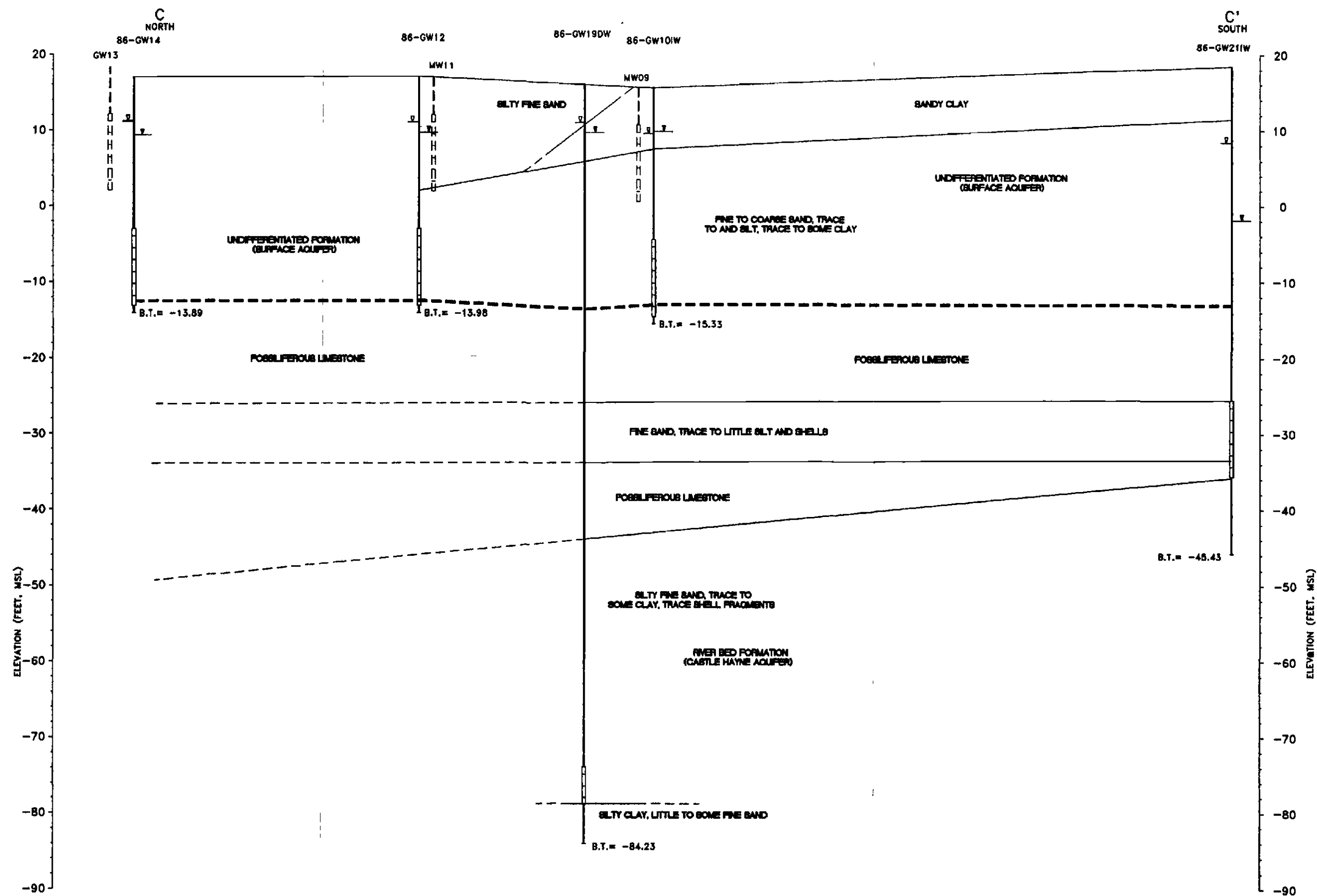
REMEDIAL INVESTIGATION, CTO-0303
 MARINE CORPS AIR STATION, NEW RIVER
 NORTH CAROLINA

BAKER ENVIRONMENTAL, Inc.
 Coraopolis, Pennsylvania

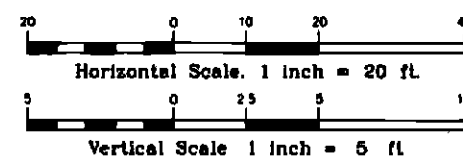


GEOLOGIC CROSS SECTIONS A-A' & B-B'		FIGURE No.
SITE 86, ABOVE GROUND STORAGE TANK AREA		2-2
SCALE	AS SHOWN	DATE
		JANUARY 1995

01719WB3X



LEGEND
 - - - - - STATIC WATER LEVEL (MAY 10, 1995)
 - - - - - GROUNDWATER ENCOUNTERED IN SOIL BORING TERMINATED, ELEVATION MSL
 B.T. = 10.0 - - - - - WELL SCREEN INTERVAL
 - - - - - ESTIMATED
 - - - - - PROJECTED
 - - - - - FORMATION CONTACT



NOTES
 - DASHED WELL SYMBOL INDICATES THAT SHALLOW WELL LOG WAS USED TO CONFIRM LITHOLOGIES PRESENTED IN INTERMEDIATE WELL LOGS.
 - THE SOIL BORING INFORMATION IS CONSIDERED TO BE REPRESENTATIVE OF SUBSURFACE CONDITIONS AT THE RESPECTIVE BORING LOCATIONS. SUBSURFACE CONDITIONS INTERPOLATED BETWEEN BORINGS ARE ESTIMATED BASED ON ACCEPTED SOIL ENGINEERING PRINCIPLES AND GEOLOGIC JUDGEMENT.

REVISIONS

DRAWN WAC
 REVIEWED MKD
 S.O.# 62470-303-0000-05200
 CADD# 303056RI

NORTH



REMEDIAL INVESTIGATION, CTO-0303
 MARINE CORPS AIR STATION, NEW RIVER
 NORTH CAROLINA

BAKER ENVIRONMENTAL, Inc.
 Coraopolis, Pennsylvania

Baker
 Baker Environmental, Inc.

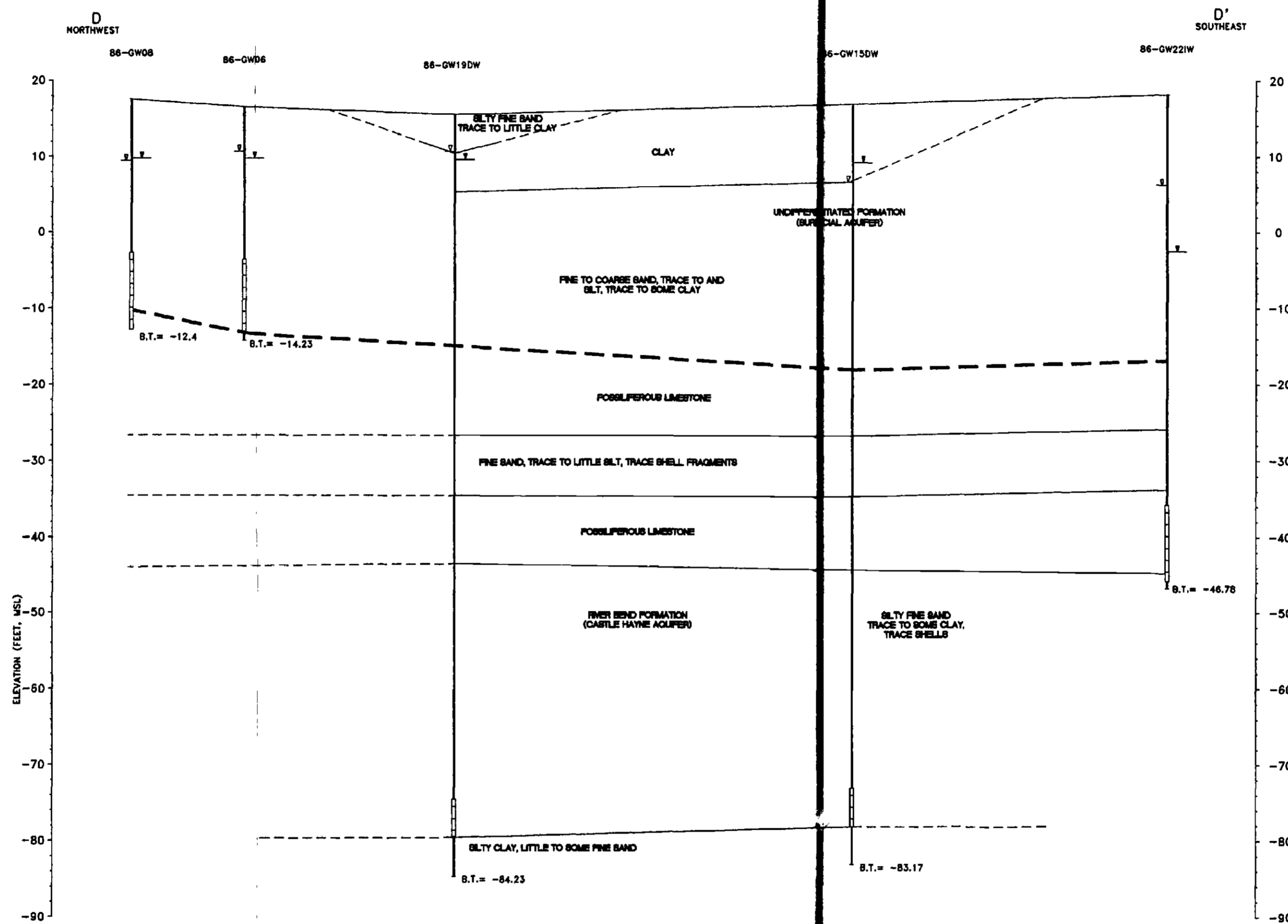
GEOLOGIC CROSS SECTION C-C'
 SITE 86, ABOVE GROUND STORAGE TANK AREA

SCALE AS SHOWN

DATE JANUARY 1996

FIGURE No.

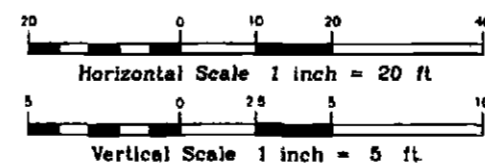
2-2
 (cont'd.)



LEGEND

- v STATIC WATER LEVEL (MAY 10, 1995)
- v GROUNDWATER ENCOUNTERED IN SOIL BORING TERMINATED, ELEVATION MSL
- B.T. -16.0 WELL SCREEN INTERVAL
- ESTIMATED
- - - PROJECTED
- FORMATION CONTACT

NOTE:
 THE SOIL BORING INFORMATION IS CONSIDERED TO BE REPRESENTATIVE OF SUBSURFACE CONDITIONS AT THE RESPECTIVE BORING LOCATIONS. SUBSURFACE CONDITIONS INTERPOLATED BETWEEN BORINGS ARE ESTIMATED BASED ON ACCEPTED SOIL ENGINEERING PRINCIPLES AND GEOLOGIC JUDGEMENT.



REVISIONS

DRAWN WAC
 REVIEWED MKD
 S.O.# 62470-303-0000-05200
 CADD# 303057RI

NORTH



REMEDIAL INVESTIGATION, CTO-0303
 MARINE CORPS AIR STATION, NEW RIVER
 NORTH CAROLINA

BAKER ENVIRONMENTAL, Inc.
 Coraopolis, Pennsylvania

Baker
 Baker Environmental, Inc.

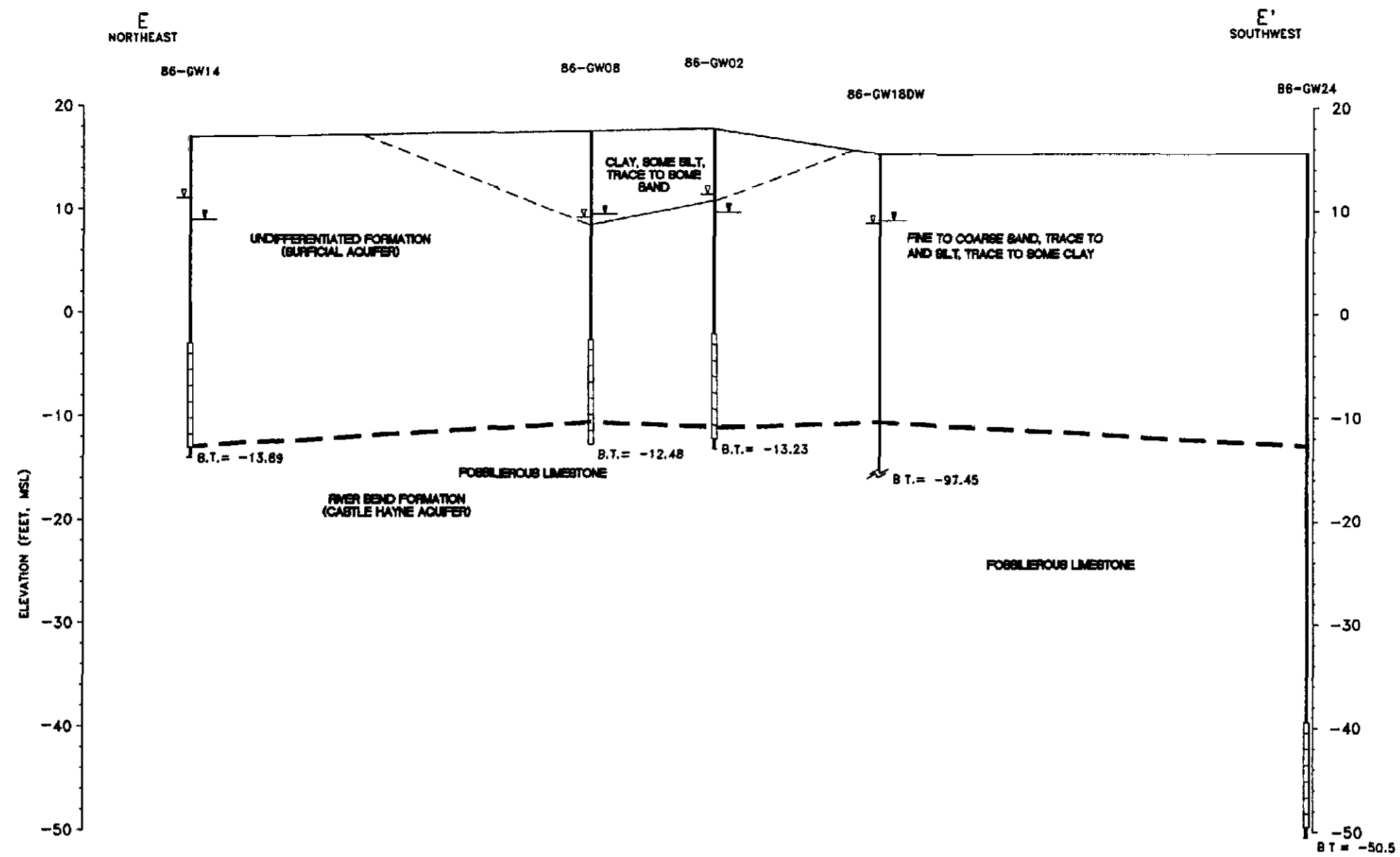
GEOLOGIC CROSS SECTION D-D'
 SITE 86, ABOVE GROUND STORAGE TANK AREA

SCALE AS SHOWN

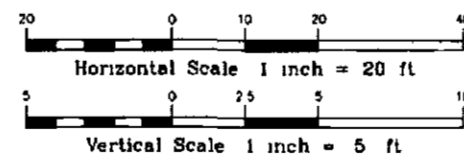
DATE JANUARY 1996

FIGURE No.

2-2
 (cont'd.)



LEGEND
 - - - - - STATIC WATER LEVEL (MAY 10, 1995)
 - - - - - GROUNDWATER ENCOUNTERED IN SOIL
 B.T. - 100 BORING TERMINATED, ELEVATION MSL
 [Symbol] WELL SCREEN INTERVAL
 [Symbol] ESTIMATED
 [Symbol] PROJECTED
 - - - - - FORMATION CONTACT



NOTE:
 -THE SOIL BORING INFORMATION IS CONSIDERED TO BE REPRESENTATIVE OF SUBSURFACE CONDITIONS AT THE RESPECTIVE BORING LOCATIONS. SUBSURFACE CONDITIONS INTERPOLATED BETWEEN BORINGS ARE ESTIMATED BASED ON ACCEPTED SOIL ENGINEERING PRINCIPLES AND GEOLOGIC JUDGEMENT

REVISIONS

DRAWN WAC
REVIEWED MKD
S.O.# 62470-303-0000-05200
CADD# 303058RI

NORTH



REMEDIAL INVESTIGATION, CTO-0303
 MARINE CORPS AIR STATION, NEW RIVER
 NORTH CAROLINA

BAKER ENVIRONMENTAL, Inc.
 Coraopolis, Pennsylvania

Baker
 Baker Environmental, Inc.

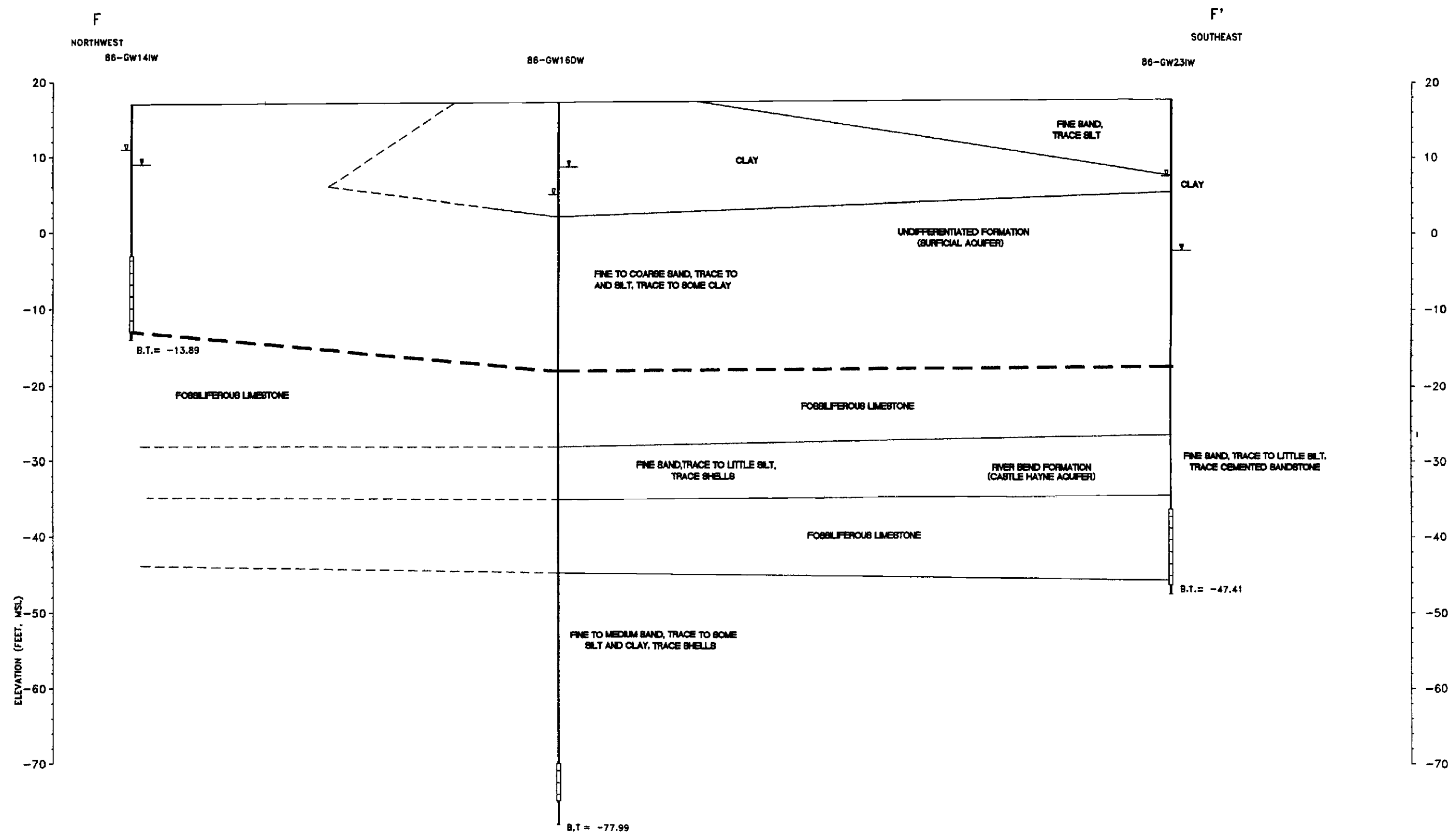
GEOLOGIC CROSS SECTION E-E'
 SITE 86, ABOVE GROUND STORAGE TANK AREA

SCALE AS SHOWN

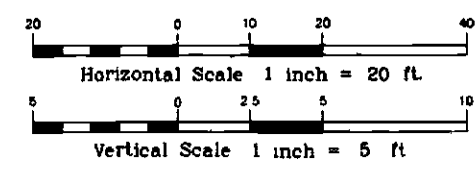
DATE JANUARY 1996

FIGURE No.

2-2
 cont'd.



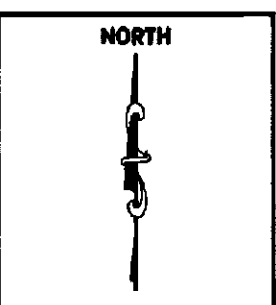
LEGEND
 ▽ STATIC WATER LEVEL (MAY 10, 1995)
 ▽ GROUNDWATER ENCOUNTERED IN SOIL BORING TERMINATED, ELEVATION MSL
 B.T. -100
 □ WELL SCREEN INTERVAL
 --- ESTIMATED
 --- PROJECTED
 --- FORMATION CONTACT



NOTE:
 -THE SOIL BORING INFORMATION IS CONSIDERED TO BE REPRESENTATIVE OF SUBSURFACE CONDITIONS AT THE RESPECTIVE BORING LOCATIONS. SUBSURFACE CONDITIONS INTERPOLATED BETWEEN BORINGS ARE ESTIMATED BASED ON ACCEPTED SOIL ENGINEERING PRINCIPLES AND GEOLOGIC JUDGMENT.

REVISIONS	
DRAWN	WAC
REVIEWED	MKD
S.O.#	62470-303-0000-05200
CADD#	303059RI

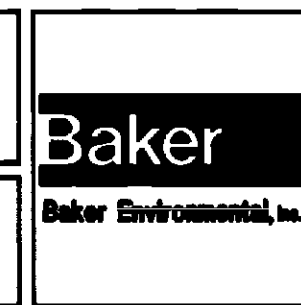
NORTH	



--

REMEDIAL INVESTIGATION, CTO-0303
 MARINE CORPS AIR STATION, NEW RIVER
 NORTH CAROLINA

BAKER ENVIRONMENTAL, Inc.
 Coraopolis, Pennsylvania



GEOLOGIC CROSS SECTION F-F'
 SITE 86, ABOVE GROUND STORAGE TANK AREA

 SCALE AS SHOWN DATE JANUARY 1996

FIGURE No.
2-2
 cont'd.

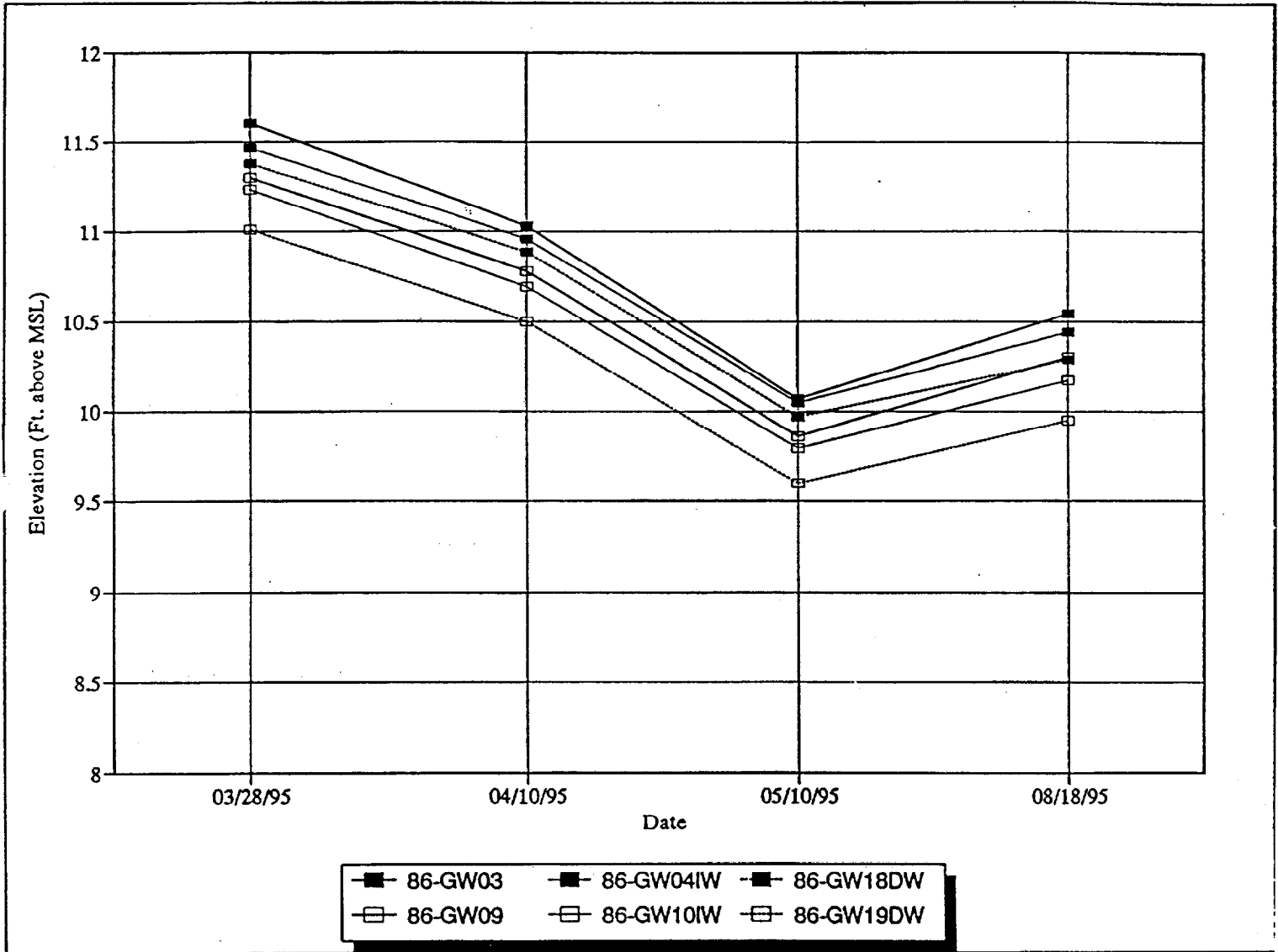


FIGURE 2-3A
GROUNDWATER ELEVATION TRENDS
AT SITE 86
REMEDIAL INVESTIGATION CTO-0303
MCB CAMP LEJEUNE, NORTH CAROLINA

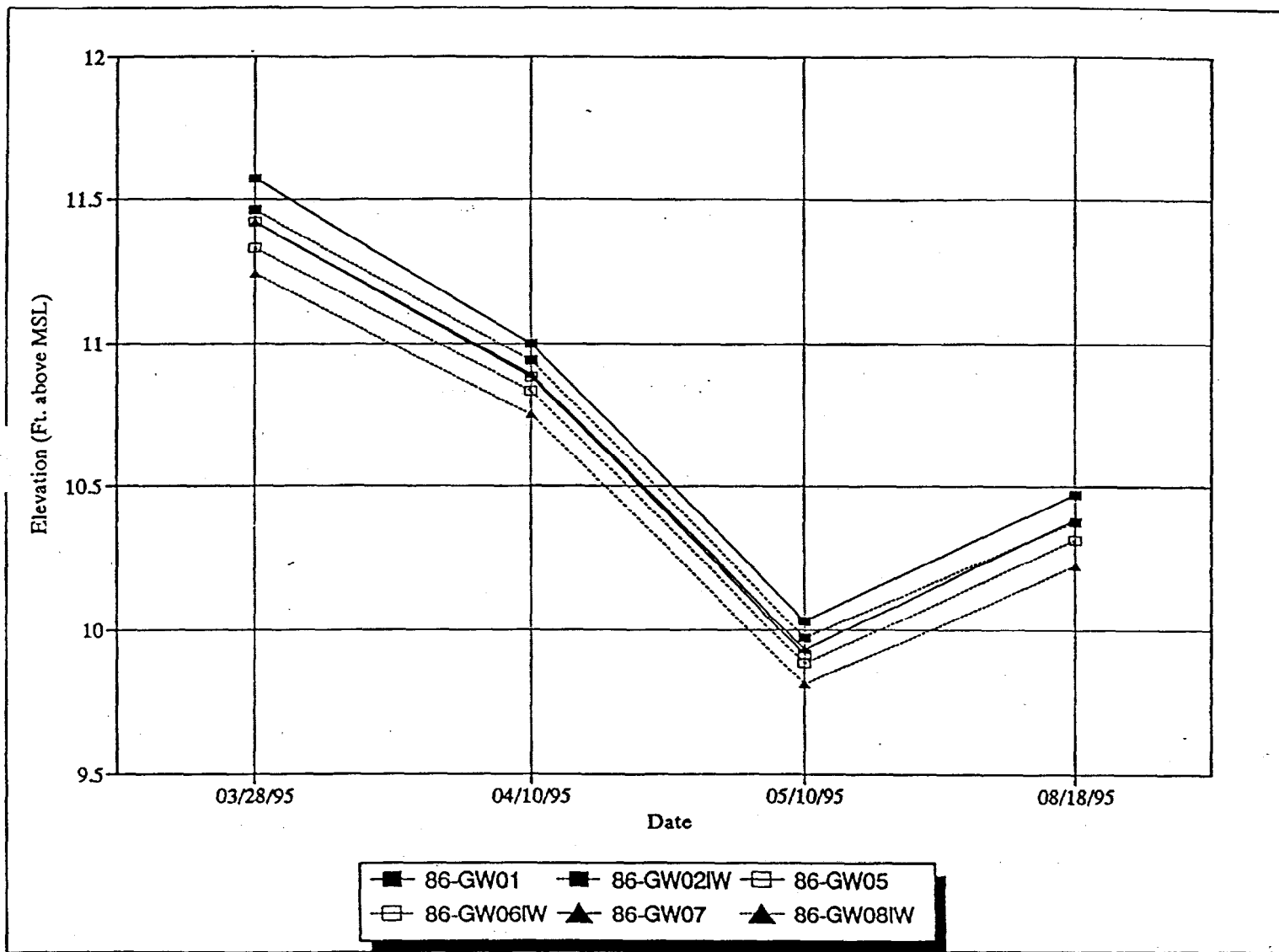


FIGURE 2-3B
GROUNDWATER ELEVATION TRENDS
AT SITE 86
REMEDIAL INVESTIGATION CTO-0303
MCB CAMP LEJEUNE, NORTH CAROLINA

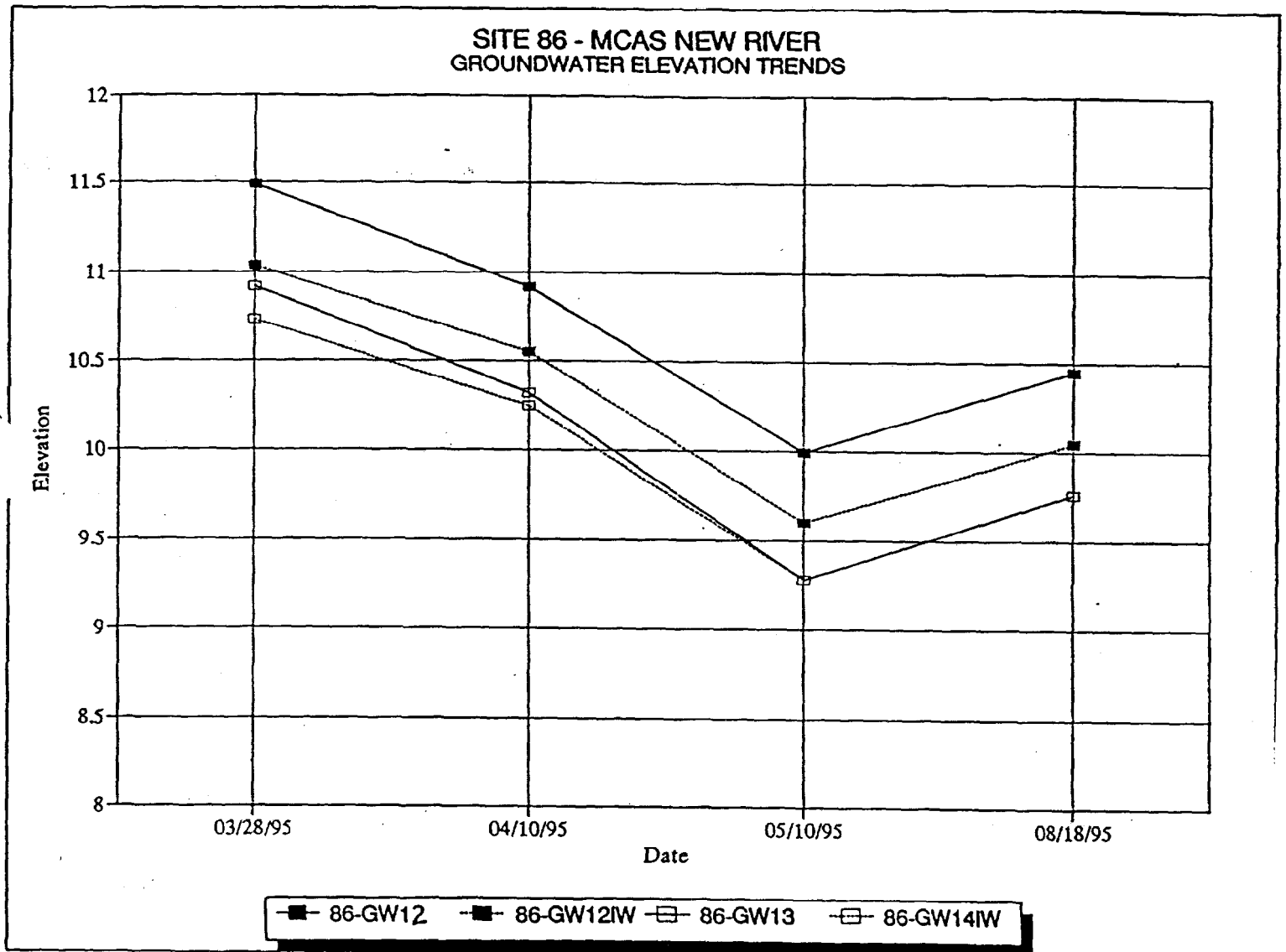


FIGURE 2-3C
 GROUNDWATER ELEVATION TRENDS
 AT SITE 86
 REMEDIAL INVESTIGATION CTO-0303
 MCB CAMP LEJEUNE, NORTH CAROLINA

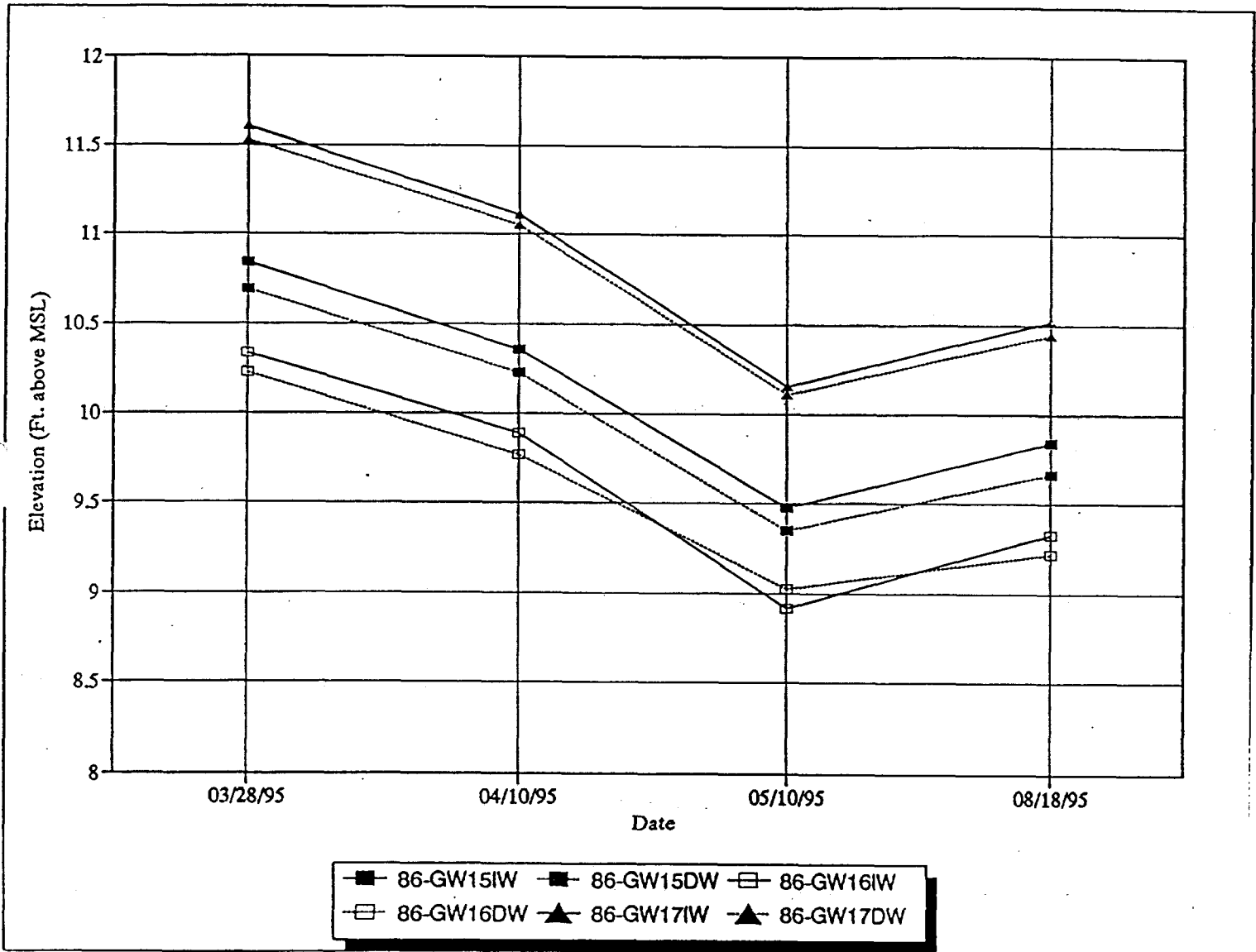


FIGURE 2-3D
 GROUNDWATER ELEVATION TRENDS
 AT SITE 86
 REMEDIAL INVESTIGATION CTO-0303
 MCB CAMP LEJEUNE, NORTH CAROLINA

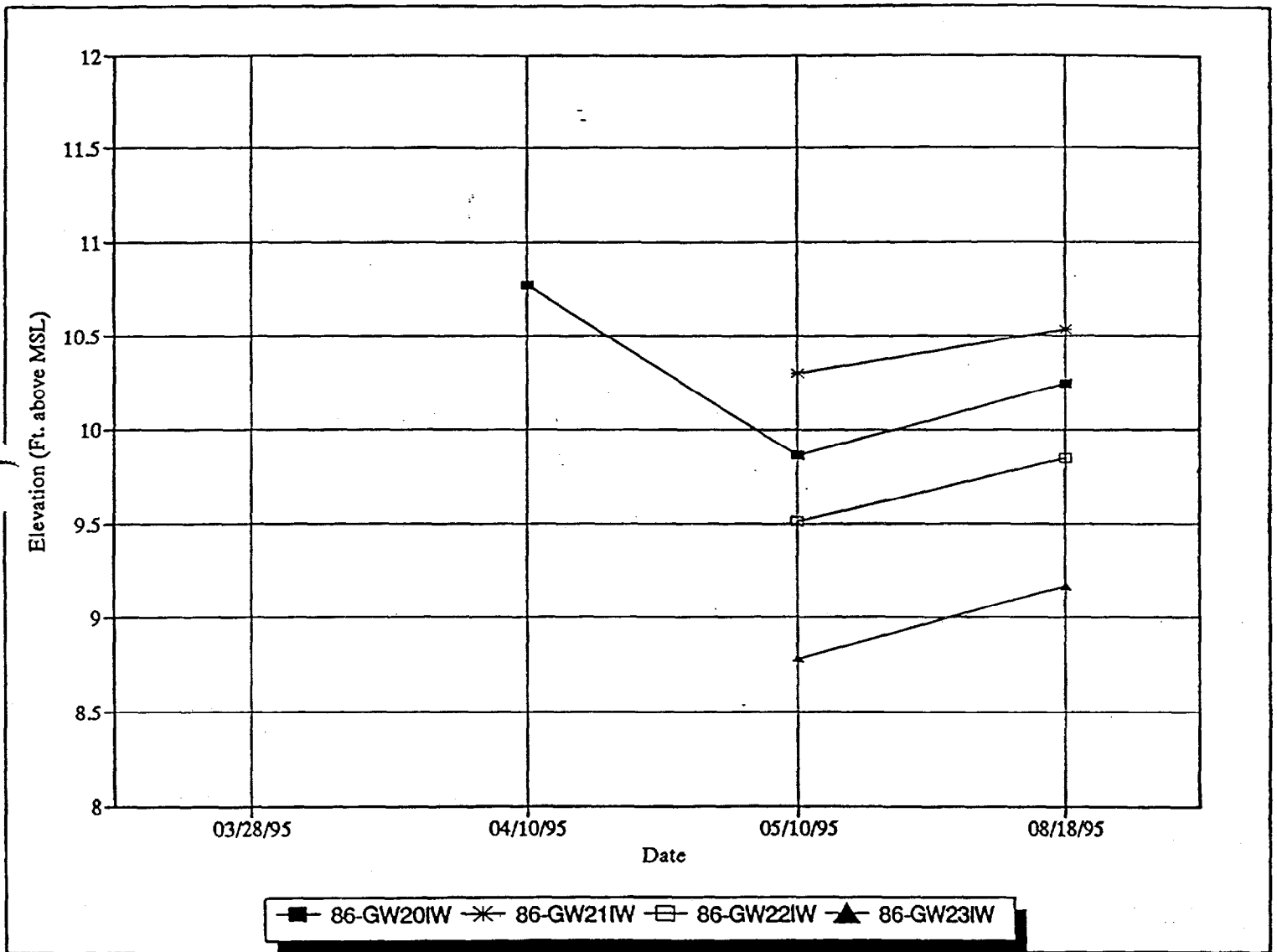
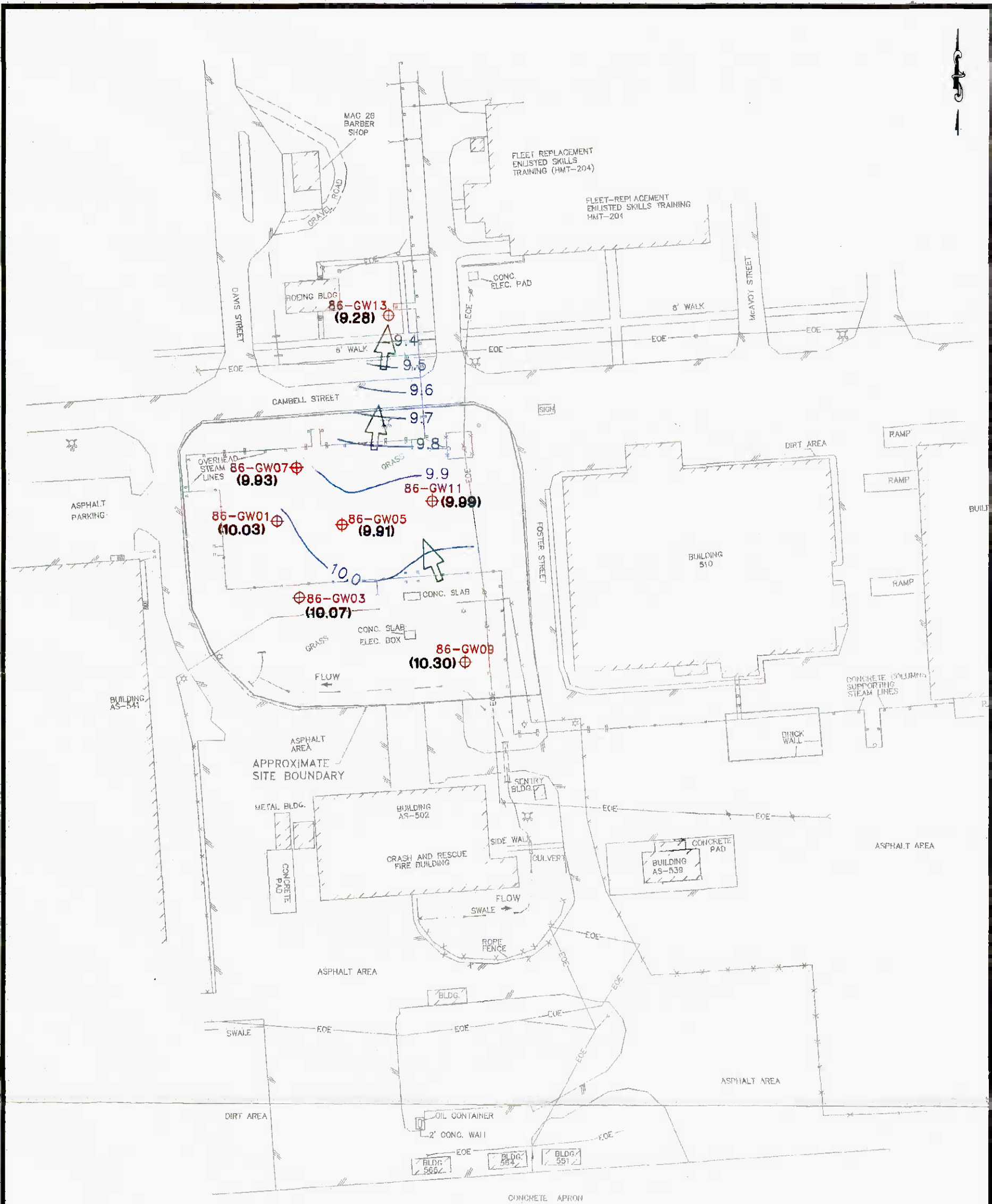


FIGURE 2-3E
GROUNDWATER ELEVATION TRENDS
AT SITE 86
REMEDIAL INVESTIGATION CTO-0303
MCB CAMP LEJEUNE, NORTH CAROLINA



303045RI

LEGEND

- ⊕ 86-GW01 SHALLOW MONITORING WELL
- 9.4 GROUNDWATER ELEVATION CONTOUR
- (9.28)** GROUNDWATER ELEVATION
- ➔ GROUNDWATER FLOW DIRECTION
- ➔ DIRECTION OF SURFACE WATER FLOW
- EOE OVERHEAD ELECTRIC LINE & UTILITY POLE
- ASPHALT ROAD
- CENTERLINE OF DRAINAGE SWALE
- ☆ LIGHTPOLE
- ▭ STRUCTURE
- GRAVEL ROAD
- FENCE
- GUY WIRE
- ⊕ FIRE HYDRANT

SOURCE: LANTDIV, OCT. 1991

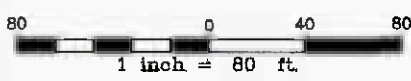
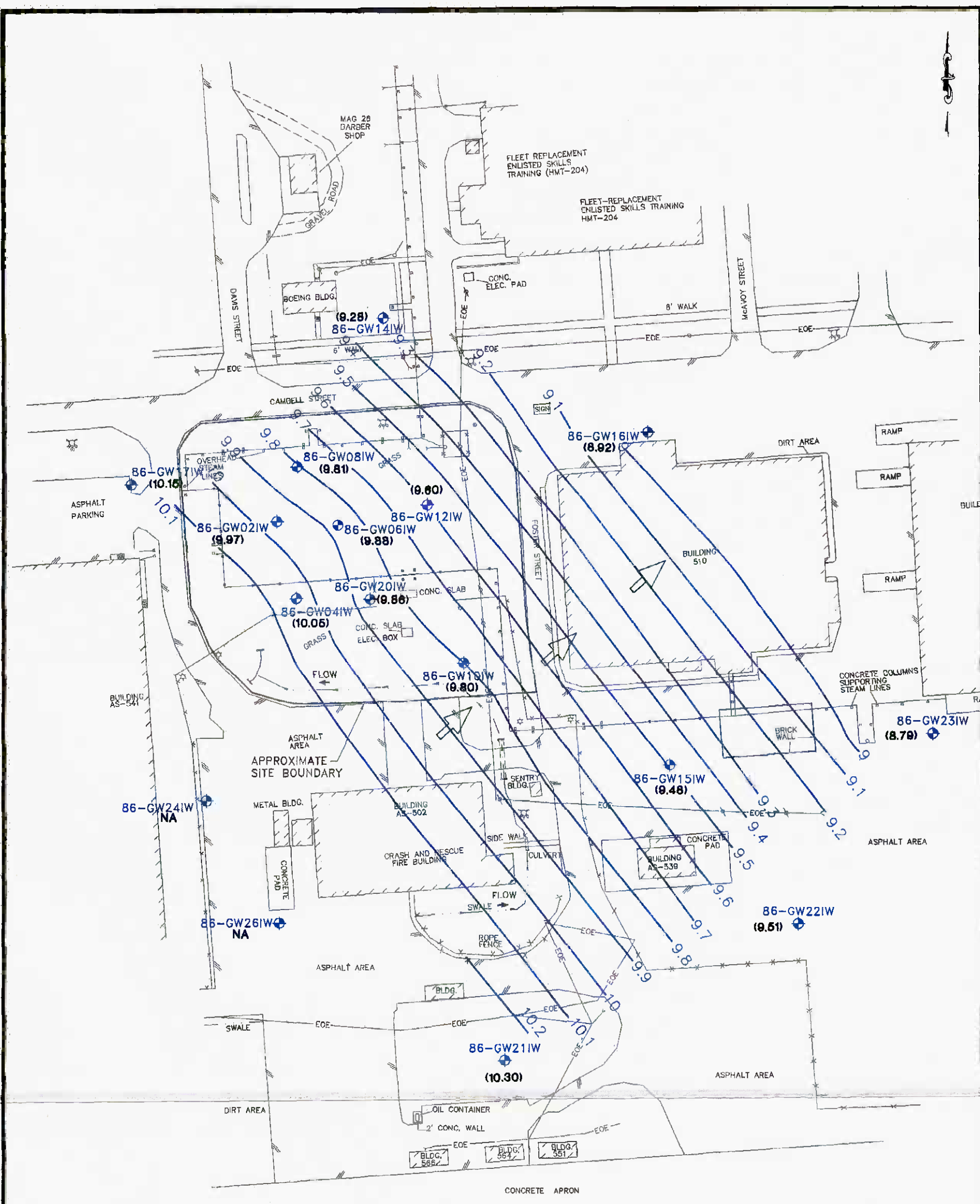


FIGURE 2-4
UPPER SURFICIAL AQUIFER GROUNDWATER
CONTOUR MAP (MAY 1995)
SITE 86, ABOVE GROUND STORAGE TANK AREA
REMEDIAL INVESTIGATION, CTO-0303
MARINE CORPS AIR STATION, NEW RIVER
NORTH CAROLINA

01719WB4V



303046R1

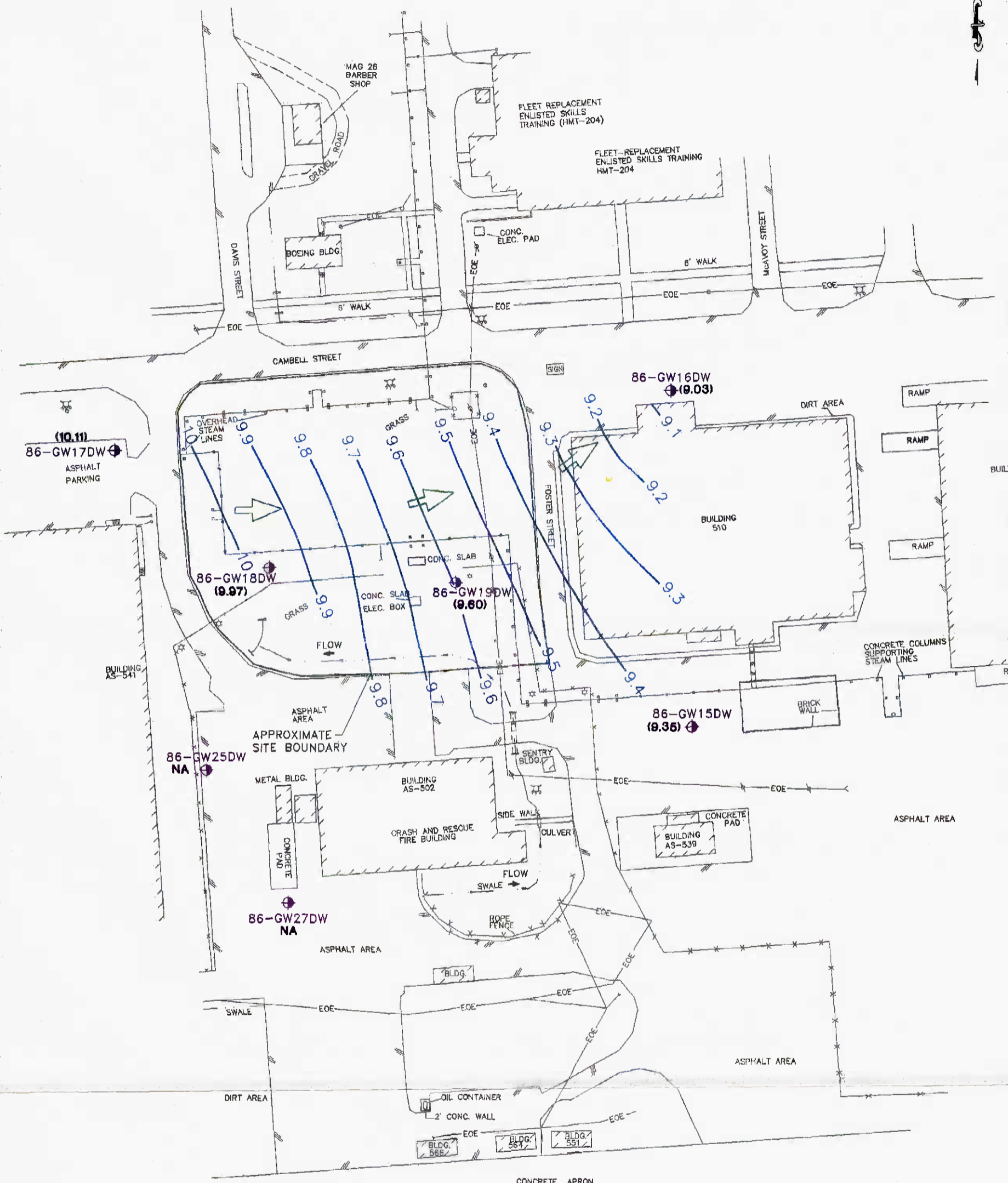
LEGEND

- | | | | |
|-----------|---------------------------------------|-----|--|
| 86-GW04IW | INTERMEDIATE MONITORING WELL | NA | NOT APPLICABLE (WELLS WERE NOT INSTALLED AT THAT TIME) |
| —10.2 | GROUNDWATER ELEVATION CONTOUR | | |
| (10.30) | GROUNDWATER ELEVATION | | |
| → | GROUNDWATER FLOW DIRECTION | | |
| → | DIRECTION OF SURFACE WATER FLOW | | |
| — | OVERHEAD ELECTRIC LINE & UTILITY POLE | | |
| — | ASPHALT ROAD | --- | GRAVEL ROAD |
| — | CENTERLINE OF DRAINAGE SWALE | —* | FENCE |
| * | LIGHTPOLE | — | GUY WIRE |
| ▭ | STRUCTURE | — | FIRE HYDRANT |

SOURCE: LANTDIV, OCT. 1991



FIGURE 2-5
 LOWER SURFICIAL AQUIFER/UPPER CASTLE HAYNE AQUIFER GROUNDWATER CONTOUR MAP (MAY 1995)
 SITE 86, ABOVE GROUND STORAGE TANK AREA
 REMEDIAL INVESTIGATION, CTO-0303
 MARINE CORPS AIR STATION, NEW RIVER
 NORTH CAROLINA



303047RI

LEGEND

- 86-GW18DW DEEP MONITORING WELL
- 9.1 GROUNDWATER ELEVATION CONTOUR
- (9.35) GROUNDWATER ELEVATION
- GROUNDWATER FLOW DIRECTION
- FLOW DIRECTION OF SURFACE WATER FLOW
- EOE OVERHEAD ELECTRIC LINE & UTILITY POLE
- ASPHALT ROAD
- CENTERLINE OF DRAINAGE SWALE
- ☆ LIGHTPOLE
- ▭ STRUCTURE
- NA NOT APPLICABLE (WELLS WERE NOT INSTALLED AT THAT TIME)
- GRAVEL ROAD
- FENCE
- GUY WIRE
- FIRE HYDRANT

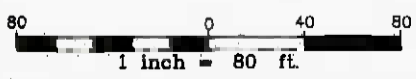
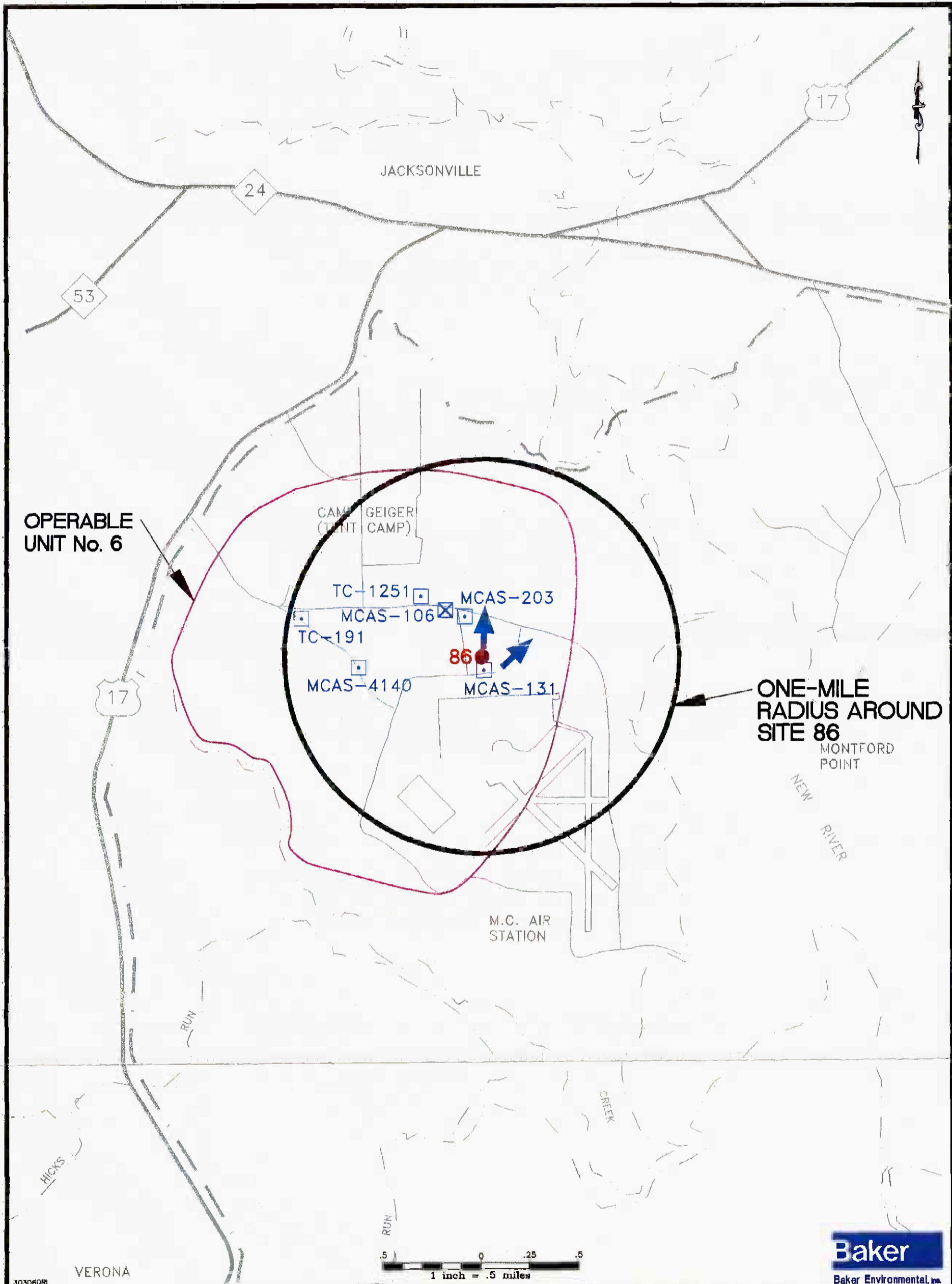


FIGURE 2-6
CASTLE HAYNE AQUIFER GROUNDWATER
CONTOUR MAP (MAY 1995)
SITE 86, ABOVE GROUND STORAGE AREA
REMEDIAL INVESTIGATION, CTO-0303
MARINE CORPS AIR STATION, NEW RIVER
NORTH CAROLINA

SOURCE: LANTDIV, OCT. 1991



OPERABLE
UNIT No. 6

ONE-MILE
RADIUS AROUND
SITE 86
MONTFORD
POINT

303060R1

VERONA

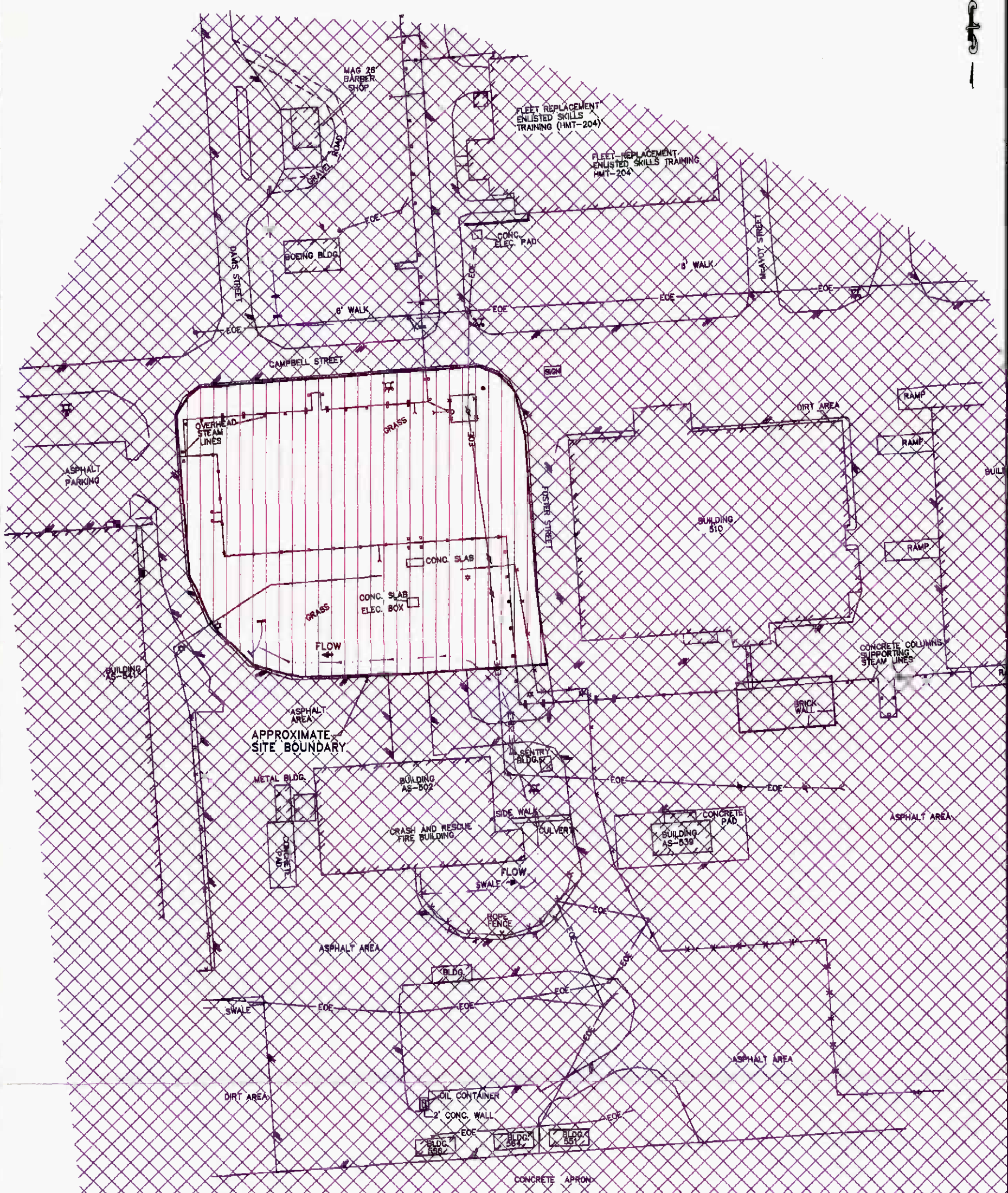
LEGEND

TC-1251	☐	- WATER SUPPLY WELL IN SERVICE
MCAS-106	☒	- WATER SUPPLY WELL OUT OF SERVICE
	➔	- APPROXIMATE DIRECTION OF GROUNDWATER FLOW FROM SITE

SOURCE: LANTDIV, OCT. 1991




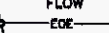



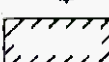



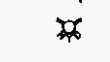
FIGURE 2-7
 POTABLE WATER SUPPLY WELLS
 WITHIN A ONE-MILE RADIUS
 SITE 86, ABOVE GROUND STORAGE TANK AREA
 REMEDIAL INVESTIGATION, CTO-0303
 MARINE CORPS BASE, CAMP LEJEUNE
 NORTH CAROLINA

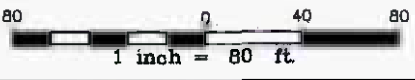




303054R1

LEGEND

-  MOWED GRASS AREA
-  INDUSTRIAL AREA
-  FLOW
-  OVERHEAD ELECTRIC LINE & UTILITY POLE
-  ASPHALT ROAD
-  CENTERLINE OF DRAINAGE SWALE
-  LIGHTPOLE
-  STRUCTURE
-  GRAVEL ROAD
-  FENCE
-  GUY WIRE
-  FIRE HYDRANT



**FIGURE 2-8
BIOHABITAT MAP
SITE 86, ABOVE GROUND STORAGE TANK AREA
REMEDIAL INVESTIGATION, CTO-0303**

MARINE CORPS AIR STATION, NEW RIVER
CAMP LEJEUNE

SOURCE: LANTDIV, OCT. 1991

3.0 STUDY AREA INVESTIGATIONS

The field investigation program at OU No. 6, Site 86, was initiated to detect and characterize potential impacts to human health and the environment resulting from past waste management activities. This section discusses the site-specific RI field investigation activities that were conducted to fulfill the objective. The RI field investigation of OU No. 6 commenced on February 20, 1995 and continued through May 10, 1995. The RI field program at Site 86 consisted of a site survey; a soil investigation, which included drilling and sampling; a groundwater investigation, which included monitoring well installation, sampling, and aquifer testing; and a habitat evaluation. The following sections detail the various investigation activities carried out during the RI.

3.1 Site Survey

The site survey task was performed in three phases: Phase I - Initial Survey of Site Features; Phase II - Post Investigation Survey of Monitoring Wells and Sampling Locations; and Phase III - Post Investigation Survey of Supplemental Monitoring Wells. Phase I of the survey task was conducted at Site 86 during March of 1995. Based upon the Site Assessment Report (O'Brien & Gere, 1992) and observed site conditions, surface features within and surrounding the former AST area were surveyed. The proposed soil boring and monitoring well locations identified in the Final RI/FS Work Plan for OU No. 6 (Baker, 1994), were subsequently located as part of the Phase I survey and marked with wooden stakes. Each sample location was assigned a unique identification number that corresponded to the site and media to be sampled.

Phase II of the site survey task was completed at Site 86 during the week of May 10, 1995. During Phase II, all existing and newly installed monitoring wells were surveyed. Supplemental or relocated soil borings and monitoring wells completed during the investigation were also surveyed. A number of soil borings and monitoring wells were relocated from their proposed locations (i.e., moved more than ten feet from their proposed locations) due to the presence of either underground or overhead utilities.

Phase III of the site survey task was performed during October of 1995. Four additional monitoring wells were installed in October at Site 86 to further define the horizontal extent of contamination within the upper and lower portions of the surficial aquifer. Latitude, longitude, and elevation in feet above mean sea level (msl) were recorded for each surveyed point.

3.2 Soil Investigation

The soil investigation performed at Site 86 was intended to:

- Assess the nature and extent of contamination that may have resulted from previous disposal practices or site activities;
- Assess the human health, ecological, and environmental risks associated with exposure to surface and subsurface soils; and
- Characterize the geologic setting of the study area.

The subsections which follow describe soil sample collection procedures, sampling locations, and the analytical program initiated during the soil investigation at Site 86.

3.2.1 Soil Sampling Procedures

Sampling activities at Site 86 commenced on February 25, 1995. Soil collection was performed using a direct-push (GeoProbe™) sampling system, advanced with a truck-mounted rig. The direct-push sampling system employed a stainless steel cutting shoe and collection tube. A dedicated acetate liner, inserted into the stainless steel collection tube, was used to collect and then extrude soil samples for field and laboratory analyses. All soil sampling activities conducted at Site 86 were performed in Level D personnel protection. Soil cuttings obtained during the soil investigation were collected, handled, and stored according to the procedures outlined in Section 3.6.

Two types of borings were installed during the soil investigation: exploratory test borings (i.e., borings installed for sample collection and description of subsurface units) and borings advanced for the purpose of monitoring well installation. Selected soil samples from each of the two types of borings were submitted for laboratory analysis (see Section 3.2.3). Soils obtained from exploratory borings were collected from the surface (i.e., ground surface to a depth of twelve inches) and at continuous two-foot intervals starting at one foot below ground surface. Continuous sample collection proceeded until the boring was terminated at the approximate depth of the water table, which varied at Site 86 from 5 to 11 feet bgs. An additional soil sample was collected from below the top of the water table to confirm groundwater depth and ensure that the true water table (i.e., not a perched zone) had been encountered.

Samples were collected for soil description from the ground surface and at continuous two-foot intervals to the water table. Each soil was classified in the field by a geologist using the Unified Soil Classification System (USCS) in accordance with the visual-manual methods described by the American Society for Testing and Materials (ASTM, 1993a). Descriptions were recorded in a field logbook and later transposed onto boring log records. Soil classification included characterization of soil type, grain size, color, moisture content, relative density, plasticity, and other pertinent information such as indications of contamination. Descriptions of site soils are provided on Test Boring Records in Appendix A and on Test Boring and Well Construction Records in Appendix B.

Surface and selected subsurface (i.e., greater than one foot below ground surface) soil samples were retained for laboratory analysis from each of the soil borings. Both surface and subsurface samples were collected to evaluate the nature and extent of potentially impacted soils and to perform the human health risk assessment; however, only the surface soils were employed for the ecological risk assessment. A summary of test boring identification numbers, boring depths, sampling intervals, and laboratory analyses for Site 86 soil samples is provided in Tables 3-1 and 3-2.

A minimum of two samples were retained for laboratory analysis from each of the soil boring locations. Each soil sample was prepared and handled according to USEPA Region IV Standard Operating Procedures (SOPs). Samples collected for volatile organic analysis were extracted with a stainless-steel spoon from different sections of the extruded soil core so that the resulting composite was representative of the entire sampling interval. Precautions were taken not to aerate the sample, thus minimizing volatilization. Samples retained for other analytical parameters (e.g., semivolatiles, pesticides, PCBs, and inorganics) were thoroughly homogenized prior to being placed in the appropriate laboratory containers.

Following sample collection, each sample retained for laboratory analysis was stored on ice in a cooler. Sample preparation also included documentation of sample number, depth, location, date, time, and analytical parameters in a field logbook. Chain-of-Custody documentation, copies of which are provided in Appendix C, included information such as sample number, date, time of sampling, and sampling personnel, accompanied the samples to the laboratory. Samples were shipped by overnight courier to the laboratory.

3.2.2 Sampling Locations

Representative samples from the study area were collected and submitted for laboratory analysis of target compound list (TCL) organics (i.e., volatiles, semivolatiles, pesticides, and PCBs), total petroleum hydrocarbons (TPH), and target analyte list (TAL) metals. A total of 20 test borings were sampled during the soil investigation at Site 86. One additional boring, to the north of the study area, was advanced to assess background contaminant concentrations (86-BB-SB01).

The sampling distribution employed at Site 86 was intended to identify if contamination was present and, if so, to evaluate the vertical and horizontal extent within the study area. The soil sampling program focused on known or suspected areas which may have been impacted by site storage operations. Previous investigatory data and background reports were used to locate potential sampling locations.

A total of 20 borings were completed at Site 86 to assess the suspected impact of former operations; four of those borings were utilized for the installation of monitoring wells. Twelve of the 20 borings were advanced from within and immediately adjacent to the former storage tank area, as stipulated in the Final RI/FS Work Plan for OU No. 6 (Baker, 1994). Soil samples were also obtained from four monitoring well test borings collected from within and surrounding the study area. The remaining four soil borings (CP-SB01, CP-SB02, WA-SB01, and WA-SB02) were collected from two separate locations where ancillary piping and equipment associated with the former storage tanks were located. Figure 3-1 depicts soil sampling locations at Site 86.

3.2.3 Analytical Program

The analytical program employed during the soil investigation at Site 86 focused on suspected contaminants of concern, as indicated by information regarding temporary storage operations and investigation results. Samples from 7 of the 20 soil boring locations were analyzed for full TCL organics (i.e., volatiles, semivolatiles, pesticides, and PCBs), TPH, and TAL metals. Full TCL organics and TAL metals analyses were requested for samples from 9 of the 20 boring locations. Samples from the remaining four locations were submitted for TCL volatile and semivolatile analyses only. Tables 3-1 and 3-2 present a summary of requested soil analyses.

One soil sample was also collected for analysis of permeability, grain size, and soil type. A thin-walled tube (i.e., shelly tube) was employed to collect, according to ASTM D-1587 (ASTM, 1994), an undisturbed sample of the semi-confining layer that separates the surficial and Castle Hayne aquifers. The sample was tested in accordance with the following procedures:

- ASTM D-422 - Particle Size Analysis of Soils (ASTM, 1990a)
- ASTM D-4318 - Liquid Limit, Plastic Limit, and Plasticity Index of Soils (ASTM, 1993b)

- ASTM D-5084 - Hydraulic Conductivity of Saturated Porous Materials (ASTM, 1990b)

Findings from these and USCS soil classification analyses are presented in Appendix L.

3.2.4 Quality Assurance and Quality Control

Field quality assurance and quality control (QA/QC) samples were collected during the soil investigation. These samples were obtained to: (1) monitor that decontamination procedures were properly implemented (equipment rinsate samples); (2) evaluate field methodologies (duplicate samples); (3) establish field background conditions (field blanks); and (4) evaluate whether cross-contamination occurred during sampling and shipping (trip blanks). Data Quality Objectives (DQOs) for the QA/QC samples were implemented in accordance with DQO Level IV as defined in the Environmental Compliance Branch SOPs and Quality Assurance Manual, USEPA Region IV (USEPA, 1991). This DQO level is equivalent to the Naval Facilities Engineering Service Center (NFESC) DQO Level D, as specified in the "Sampling and Chemical Analysis Quality Assurance Requirements for the Navy Installation Restoration Programs" document (NEESA, 1988).

Four types of field QA/QC samples were collected and analyzed including: duplicate samples; equipment rinsates samples; field blanks; and trip blanks. The definition of each is listed below (USEPA, 1991):

- **Duplicate Sample:** Two or more samples collected simultaneously into separate containers from the same source under identical conditions.
- **Equipment Blanks:** Equipment field blanks (or rinsate blanks) are defined as samples which are obtained by running organic free water over/through sample collection equipment after it has been cleaned. These samples are used to determine if decontamination procedures were adequate. A minimum of one equipment blank per sample media was collected daily, however, only every other blank was analyzed.
- **Field Blanks:** Organic-free water is taken to the field in sealed containers and poured into the appropriate sample containers at designated locations. This is done to determine if contaminants present in the area may have an affect on the sample integrity.
- **Trip Blanks:** Trip blanks are prepared prior to the sampling event, placed in the actual sample container, and kept with the investigative samples throughout the sampling event. They are then packaged for shipment with the other samples and sent for analysis. At no time after their preparation are the sample containers to be opened before they return to the laboratory. Field sampling teams utilize volatile organic trip blanks to determine if samples were contaminated during storage and transportation back to the laboratory. If samples are to be shipped, trip blanks are to be provided for each shipment but not necessarily for each cooler (i.e., trip blanks in coolers with samples for VOC analyses only).

Table 3-3 summarizes field QA/QC sample types, sample frequencies, the number of QA/QC samples, and parameters analyzed. Field QA/QC samples were collected at Site 86 according to the procedures outlined in the USEPA Region IV SOPs.

3.2.5 Air Monitoring and Field Screening

Several air monitoring and field screening procedures were implemented during soil investigation activities at Site 86. Ambient air monitoring for volatile contaminants was performed at each open borehole using a photoionization detector (PID). Soil samples were also field screened for volatile organic contaminants with a PID. Measurements obtained in the field were recorded in a logbook and later transposed onto the Test Boring Records and the Well Construction Records provided in Appendices A and B. Prior to daily monitoring, the field instruments were calibrated and documentation was recorded in a field logbook and on appropriate calibration forms.

3.3 Groundwater Investigation

The groundwater investigation performed at Site 86 was intended to:

- Assess the nature and extent of contamination that may have resulted from previous disposal practices or site activities;
- Assess human health and environmental risks associated with exposure to groundwater; and
- Characterize the hydrogeologic setting of the study area.

The subsections which follow describe well installation procedures, well development procedures, sampling locations, sample collection procedures, the analytical program, and hydraulic conductivity test procedures employed during the groundwater investigation at Site 86.

3.3.1 Monitoring Well Installation

Two shallow and nine intermediate Type II monitoring wells (i.e., wells installed without casing to seal off a semi-confining or confining layer) were installed at Site 86 during March, April, May, and October of 1995. Locations of the newly installed monitoring wells are depicted on Figure 3-2. The monitoring wells were situated spatially to intercept potentially impacted groundwater from the former storage tank area, and to characterize the nature and horizontal extent of possible contamination. The existing and newly-installed monitoring wells were also used to evaluate groundwater flow patterns within the surficial aquifer. In addition to the shallow and intermediate monitoring wells, five deep Type III monitoring wells (i.e., wells installed with casing to seal off a confining or semi-confining layer) were installed during February and March of 1995, at Site 86 (refer to Figure 3-2). The deep monitoring wells were installed to assess the nature and vertical extent of groundwater contamination at Site 86. Placement of the newly installed monitoring wells was based on review of previous investigation results and analytical data gathered during the initial phase of the field investigation.

The two shallow monitoring wells were installed after pilot hole test borings were advanced to the desired depth. Each borehole was reamed with a 6-1/4-inch inside diameter (ID) hollow stem augers prior to well installation. The two shallow wells were each installed at a depth of 30 feet below

ground surface. In general, the shallow wells were installed approximately 10 feet below the water table encountered during the pilot hole test boring. Shallow monitoring wells were installed with screened intervals bisecting the water table sufficiently to compensate for seasonal variations in the water table which is known to fluctuate from 2 to 4 feet. Well construction details are summarized in Table 3-4, and well construction diagrams are shown on the Test Boring and Well Construction Records provided in Appendix B.

The intermediate and deep monitoring wells were installed upon completion of pilot hole test borings, advanced using mud and wash rotary drilling methods. Each borehole was reamed with a 6-inch wing bit prior to well installation. The nine intermediate wells were screened at intervals from approximately 54 to 64 feet below ground surface, resting upon semi-confining, less permeable, geologic material (i.e., a combination of sand, silt, and clay) at the bottom of the surficial aquifer. The five deep monitoring wells were screened at intervals just below the semi-confining unit in the upper portion of the Castle Hayne aquifer. Screened intervals for the deep wells ranged from approximately 87 to 108 feet below ground surface (refer to Table 3-4 and Appendix B for well construction details).

All of the permanent monitoring wells were constructed of two-inch nominal diameter, Schedule 40, flush-joint and threaded, polyvinyl chloride (PVC) casing. Justification for the use of PVC casing is provided in Appendix B of the Field Sampling and Analysis Plan for Operable Unit No. 6 (Baker, 1994). Each shallow well utilized a 15-foot screened interval comprised of a 10- and 5-foot long No. 10 (i.e., 0.01 inch) slotted screen sections. Intermediate and deep monitoring wells were constructed with 10-foot and 5-foot No. 10 slotted screen sections, respectively. A fine-grained sand pack (i.e., No. 1 silica sand), extending approximately two feet above the top of the screen, was placed in the annulus between the screen and the borehole wall from inside the augers during shallow well installation. The sand pack was poured manually down the borehole during both intermediate and deep well installation, and continuously checked with a weighted tape measure to determine sand pack depth. A two- to three-foot sodium bentonite pellet seal was placed above the sand pack by dropping pellets down the borehole. The bentonite pellets were hydrated with potable water after placement. A sodium bentonite slurry was used to backfill the annular space from above the bentonite pellet seal to the bottom of the steel casing (i.e., above the semi-confining unit). The remaining annular space was backfilled with a mixture of Portland cement and five percent powdered bentonite. During construction of the Type III deep wells, portland cement was used to secure six-inch steel casing to the uppermost portion of the semi-confining layer. A five-foot by five-foot concrete pad was placed around the protective well casing and four protective bollard posts were installed around the corners of the concrete pad, where feasible. A four-inch protective well casing with locking cover was placed over the well and set into the cement. Well tags, which provide construction information, were installed at the top of each well. Typical shallow and intermediate Type II well construction details are depicted on Figures 3-3 and 3-4, respectively. Typical construction details for a Type III monitoring well are provided on Figure 3-5.

3.3.2 Monitoring Well Development

Following well construction and curing of the bentonite seal and cement grout, each newly installed monitoring well was developed to remove fine-grained sediment from the sandpack and to establish interconnection between the well and the surrounding formation. The shallow wells were developed by a combination of surging and pumping. The intermediate and deep wells were developed using a forced air system (with filter) and "lifting" the water out of the well. Typically, 20 to 50 gallons of water were evacuated from the shallow and intermediate wells, followed by 10 minutes of

surging, then continued pumping. Three to five borehole volumes were evacuated from each deep well, typically 100 to 250 gallons. Groundwater recovered during well development was temporarily stored in drums, then transferred into on-site storage tanks (refer to Section 3.6). Pumping hoses, constructed of flexible PVC, were used once and discarded to minimize the potential for cross contamination.

Three to five borehole volumes were removed from each well, where conditions permitted, until the groundwater was essentially sediment-free. Measurements of pH, specific conductance, and temperature were recorded after each volume was removed to assist in assessing well stabilization. Additionally, periodic flow and volume measurements were also recorded during development to evaluate flow rates of the shallow water-bearing zone. Well Development Records that summarize this information are provided in Appendix D.

3.3.3 Water Level Measurements

Static water level measurements were collected after all well development activities had been completed. Measurements were recorded from top-of-casing (TOC) reference points marked on the PVC casing at each existing and newly-installed well. Water level measurements were collected on March 28, April 10, May 10, and August 18, 1995. Groundwater measurements were recorded using an electric measuring tape which were recorded to the nearest 0.01 foot. Water level data from site monitoring wells and staff gauges were collected within a three-hour period. A summary of water level measurements is provided in Table 3-5.

3.3.4 Aquifer Testing

Well-head tests (i.e., slug tests) were performed on selected wells at Site 86 as part of the groundwater investigation. Aquifer testing results, provided in Appendix M. Both falling- and rising-head tests were performed to approximate individual well characteristics and to provide generalized information regarding aquifer parameters within the study area.

3.3.5 Sampling Locations

Groundwater samples were collected from seven existing shallow wells, two newly installed shallow wells, seven existing intermediate wells, nine newly installed intermediate wells, and five newly installed deep wells at Site 86. The locations of the newly installed and existing monitoring wells are depicted on Figure 3-2. Groundwater samples were collected at Site 86 in March, April, May, and October of 1995.

During March of 1995 groundwater samples were submitted for laboratory analysis from the seven existing shallow and seven existing intermediate monitoring wells, five newly installed intermediate wells, and five newly installed deep wells. Based upon preliminary analytical results from these 24 monitoring wells, an additional four intermediate monitoring wells were proposed to further define the horizontal extent of site contamination. One of the four additional intermediate monitoring wells was installed within 75 feet of the former ASTs (86-GW20IW); the remaining three intermediate monitoring wells were installed over 300 feet to the south and southeast of the study area to determine whether contaminants had migrated from an off-site source (86-GW21IW, 86-GW22IW, and 86-GW23IW). Samples from the four additional intermediate wells were submitted for laboratory analysis during April and May of 1995.

Analytical results generated during the groundwater investigation at Site 86 indicated the presence of surficial groundwater contamination. An additional four monitoring wells, two shallow (86-GW25 and 86-GW27) and two intermediate (86-GW24IW and 86-GW26IW), were proposed to determine if the observed contaminants were the result of on-site operations or the product of an upgradient source. The four additional monitoring wells were installed during October of 1995. The two well clusters were placed to the south and southwest of the study area, each cluster with one shallow and one intermediate well. Figure 3-2 depicts the 30 groundwater sampling locations at Site 86.

3.3.6 Sampling Procedures

Groundwater samples were collected to assess whether contamination was present in the shallow aquifer, which may have resulted from previous storage operations at Site 86. Accordingly, the sampling program initiated at Site 86 focused on these contaminants.

Prior to groundwater purging, a water level measurement from each well was obtained according to procedures outlined in Section 3.3.3. The total well depth was also recorded from each well to the nearest 0.1 foot using a decontaminated steel tape. Water level and well depth measurements were used to calculate the volume of water in each well and the volume of water necessary to purge the well.

A minimum of three to five well volumes were purged from each well prior to sampling. Measurements of pH, specific conductance, temperature, and turbidity were taken after each well volume was purged to ensure that groundwater characteristics had stabilized before sampling. These measurements were recorded in a field logbook and are provided in Tables 3-6 and 3-7. Purge water was contained and handled as described in Section 3.6.

During the groundwater sampling event, a low flow well purging and sampling technique was employed. The sampling methodology was developed in response to conversations with USEPA Region IV personnel in Athens, Georgia. A peristaltic pump (GeoPump™), with the intake set two to three feet into the static water column, was used to purge each of the wells. While purging groundwater from each of the monitoring wells, a flow rate of less than 0.25 gallons per minute (gpm) was maintained. Samples collected for both organic and metal analyses were obtained directly from the pump discharge. The Teflon™ tubing was decontaminated with a Liquinox soap solution and thoroughly rinsed with deionized water (refer to Section 3.5 for decontamination procedures). A dedicated one-foot section of silicon pump-head tubing was used during purge and sampling activities at each well. Rinsate blanks were collected from the Teflon™ and silicon tubing to verify that proper decontamination procedures were being followed.

Preparation of groundwater samples incorporated procedures similar to those described for soil samples. Sample information, including well number, sample identification, time and date of sample collection, samplers, analytical parameters, and required laboratory turnaround time, was recorded in a field logbook and on the sample labels. Chain-of-custody documentation (provided in Appendix C) accompanied the samples to the laboratory.

3.3.7 Analytical Program

Groundwater samples from seven existing shallow wells, seven existing intermediate wells, two newly installed shallow wells, nine newly installed intermediate wells, and five newly installed deep

wells were submitted for laboratory analysis from Site 86. Samples from each of the 14 existing wells (86-GW01 through 86-GW14IW), four of the newly installed intermediate wells (86-GW15IW, 86-GW16IW, 86-GW17IW, and 86-GW20IW), and the 5 newly installed deep wells (86-GW15DW, 86-GW16DW, 86-GW17DW, 86-GW18DW, and 86-GW19DW) were analyzed for full TCL volatiles, TCL semivolatiles, TAL total metals, total suspended solids (TSS), and total dissolved solids (TDS). Groundwater samples obtained from three intermediate wells (86-GW21IW, 86-GW22IW, and 86-GW23IW) to the south and southeast of the study area were analyzed for TCL volatiles, TAL metals, TSS, and TDS. In addition, a limited number of groundwater samples were also analyzed for TCL pesticides, TCL PCBs, and TAL dissolved metals. The groundwater samples were analyzed using Contract Laboratory Program (CLP) protocols and Level IV data quality.

During October of 1995 an additional groundwater sampling event was conducted at Site 86 to confirm the presence of volatile organic compounds in the surficial aquifer. During this second sampling event groundwater samples were collected from 11 of the monitoring wells that exhibited volatile contaminants during the initial sampling round. In addition, samples were collected from two newly installed shallow and two newly installed intermediate monitoring wells. Each of the 11 samples were submitted for laboratory analysis of TCL volatiles only. Tables 3-8 and 3-9 provide a summaries of groundwater samples submitted for laboratory analysis during the groundwater investigation at Site 86.

3.3.8 Quality Assurance and Quality Control

Field QA/QC samples were also submitted for analyses during the groundwater investigation. These samples included trip blanks, equipment rinsates, and duplicates. Equipment rinsates were collected from the peristaltic pump and Teflon™ tubing after decontamination was completed and prior to reuse. Section 3.2.4 provides a summary of QA/QC samples collected during the investigation. Table 3-10 summarizes the QA/QC sampling program employed for the groundwater investigation conducted at Site 86.

3.3.9 Field Screening and Air Monitoring

Air monitoring and field screening procedures for volatile organic vapors implemented at Site 86 included the screening of well-heads and the purged groundwater with a PID. Measurements obtained in the field were recorded in a field logbook. Prior to daily monitoring, the field instruments were calibrated and documentation was recorded in a field logbook and on calibration forms.

3.4 Habitat Evaluation

During the habitat evaluation at Site 86, dominant vegetation types and species were identified in the field; those plants that could not be readily identified were collected for further examination in the office. Amphibians, reptiles, birds, and mammals were also identified as visual sightings or evidence allowed. From this information, ecological communities were established and biohabitat maps developed (refer to Section 2.0).

3.5 Decontamination Procedures

Decontamination procedures performed in the field were initiated in accordance with USEPA Region IV SOPs. Sampling and drilling equipment were divided into two decontamination groups, heavy equipment and routine sample collection equipment. Heavy equipment included the drill rig, hollow-stem augers, and drill and sampling rods. Routine sample collection equipment included split spoons, stainless steel core barrels (used with the GeoProbe™), and stainless steel spoons and bowls, and Teflon™ tubing.

The following procedures were implemented for heavy equipment:

- Removal of caked-on soil with brush
- Steam clean with high-pressure steam
- Air dry

The following procedures were implemented for routine sample collection equipment:

- Clean with distilled water and laboratory detergent (Liquinox soap solution)
- Rinse thoroughly with distilled water
- Rinse twice with isopropol alcohol
- Air dry
- Wrap in aluminum foil, if appropriate

Temporary decontamination pads, constructed of wood and plastic, were constructed to prevent spillage of fluids onto the ground surface. Decontamination fluids generated during the field program were containerized and handled according to the procedures outlined in Section 3.6.

3.6 Investigation Derived Waste (IDW) Handling

Field investigation activities at Site 86 resulted in the generation of various IDW. This IDW included drilling mud, soil cuttings, well development and purge water, and solutions used to decontaminate non-disposable sampling equipment. The general management techniques utilized for the IDW were:

1. Collection and containerization of IDW material.
2. Temporary storage of IDW while awaiting confirmatory analytical data.
3. Final disposal of aqueous and solid IDW material.

The management of the IDW was performed in accordance with guidelines developed by the USEPA Office of Emergency and Remedial Response, Hazardous Site Control Division (USEPA, 1992). Both the IDW soils and water were returned, based on confirmatory analytical data, to their respective source areas. Contaminated wastewater was sent off site to a licensed hazardous waste disposal facility. Appendix E provides information regarding the management and disposal of the IDW.

3.7 References

American Society for Testing and Materials (ASTM). 1990a. Standard Test Method for Particle Size Analysis of Soils. ASTM D-422-63 (Reapproved 1990). American Society for Testing and Materials, Philadelphia, Pennsylvania.

American Society for Testing and Materials (ASTM). 1990b. Test Method for Hydraulic Conductivity of Saturated Porous Materials Using a Flexible Wall Permeameter. ASTM D-5084-90. American Society for Testing and Materials, Philadelphia, Pennsylvania.

American Society for Testing and Materials (ASTM). 1993a. Standard Practice for Description and Identification of Soils (Visual Manual Procedure). ASTM D-2488-93. American Society for Testing and Materials, Philadelphia, Pennsylvania.

American Society for Testing and Materials (ASTM). 1993b. Standard Test Method for Liquid Limit, Plastic Limit, and Plasticity Index of Soils. ASTM D-4318-93. American Society for Testing and Materials, Philadelphia, Pennsylvania.

American Society for Testing and Materials (ASTM). 1994b. Standard Practice for Thin-Walled Tube Geotechnical Sampling of Soils. ASTM D-1587-94. American Society for Testing and Materials, Philadelphia, Pennsylvania.

Baker Environmental, Inc. 1994. Remedial Investigation/Feasibility Study Work Plan for Operable Unit No. 6 (Sites 43, 43, 86, 86, and 86), Marine Corps Base Camp Lejeune, North Carolina. Final. Prepared for the Department of the Navy, Naval Facilities Engineering Command, Atlantic Division, Norfolk, Virginia. December 1994.

Naval Energy and Environmental Support Activity (NEESA). 1988. Sampling and Chemical Analysis Quality Assurance Requirements for the Navy Installation Restoration Program. Department of the Navy, Naval Energy and Environmental Support Activity, Port Hueneme, California. NEESA 20.2-047B.

O'Brien & Gere Engineers, Inc. 1992. Site Assessment Tanks AS419 - AS421. Marine Corps Air Station, New River, North Carolina. Prepared for the Department of the Navy, Naval Facilities Engineering Command, Atlantic Division, Norfolk, Virginia. Contract No.62470-90-R-7626. June 1992.

United States Environmental Protection Agency (USEPA). 1991. National Functional Guidelines for Organic Data Review. Draft. USEPA Contract Laboratory Program. June 1991.

United States Environmental Protection Agency (USEPA). 1992. Guide to Management of Investigation-Derived Wastes. Office of Emergency and Remedial Response Hazardous Site Control Division. Washington, D.C. OS-220W. April 1992.

SECTION 3.0 TABLES

TABLE 3-1

**SOIL SAMPLING SUMMARY
TEST BORINGS
SITE 86, ABOVE GROUND STORAGE TANK AREA
REMEDIAL INVESTIGATION, CTO-0303
MCAS, NEW RIVER, NORTH CAROLINA**

Sample Location	Depth of Borehole (feet, below ground surface)	Sampling Interval (feet, below ground surface)	Analytical Parameters						
			TCL Pest/PCB	TAL Metals	TPH	TCL VOA	TCL SVOA	Duplicate Sample	MS/ MSD
86-AST-SB01	9	0-3	X	X		X	X		
		3-5	X	X		X	X		
86-AST-SB02	13	0-1	X	X	X	X	X		
		3-5	X	X	X	X	X		
		9-11	X	X	X	X	X		
86-AST-SB03	11	0-1	X	X		X	X		
		7-9	X	X		X	X		
86-AST-SB04	7	0-1	X	X	X	X	X		
		3-5	X	X	X	X	X		
86-AST-SB05	9.5	0-1	X	X		X	X	X	X
		5-7	X	X		X	X		
		9-9.5	X	X		X	X		
86-AST-SB06	9	0-1	X	X	X	X	X		
		7-9	X	X	X	X	X		
86-AST-SB07	11	0-1	X	X		X	X		
		5-7	X	X		X	X		
86-AST-SB08	11	0-1	X	X		X	X		
		7-9	X	X		X	X		
86-AST-SB09	9	0-1	X	X	X	X	X		
		7-9	X	X	X	X	X		
86-AST-SB10	9	0-1			X	X	X		
		7-9			X	X	X		
86-AST-SB11	9	0-1			X	X	X		
		5-7			X	X	X		
86-AST-SB12	9	0-1			X	X	X		
		5-7			X	X	X		
86-CP-SB01	9	0-1				X	X		
		3-5				X	X		
86-CP-SB02	9	0-1				X	X		
		3-5				X	X		
86-WA-SB01	5	0-1				X	X		
		3-5				X	X		
86-WA-SB02	9	0-1				X	X		
		5-7				X	X		
86-BB-SB01 ⁽¹⁾	7	0-1	X	X		X	X		
		3-5	X	X		X	X		

Notes: ⁽¹⁾ Background or control sample location

TABLE 3-2

**SOIL SAMPLING SUMMARY
MONITORING WELL TEST BORINGS
SITE 86, ABOVE GROUND STORAGE TANK AREA
REMEDIAL INVESTIGATION, CTO-0303
MCAS, NEW RIVER, NORTH CAROLINA**

Sample Location	Depth of Borehole (feet, below ground surface)	Sampling Interval (feet, below ground surface)	Analytical Parameters						
			TCL Pest/PCB	TAL Metals	TPH	TCL VOA	TCL SVOA	Duplicate Sample	MS/MSD
86-GW15IW	57	2-4	X	X		X	X		
86-GW17IW	57	1-3	X	X		X	X	X	
		3-5	X	X		X	X		
86-GW18DW	113	0-1	X	X		X	X		
		3-5	X	X		X	X		
86-GW19DW	100	0-1	X	X		X	X		X
		3-5	X	X		X	X		

TABLE 3-3

**QUALITY ASSURANCE/QUALITY CONTROL SAMPLING PROGRAM
SOIL INVESTIGATION
SITE 86, ABOVE GROUND STORAGE TANK AREA
REMEDIAL INVESTIGATION, CTO-0303
MCAS, NEW RIVER, NORTH CAROLINA**

QA/QC Sample ⁽¹⁾	Frequency of Collection	Number of Samples	Analytical Parameters
Trip Blanks ⁽²⁾	One per cooler	4	TCL Volatiles
Field Blanks ⁽³⁾	One per event	1	TCL VOA, TCL SVOA, TCL Pest/PCB, TAL Metals
Equipment Rinsates ⁽⁴⁾	One per day	3	TCL VOA, TCL SVOA, TCL Pest/PCB, TAL Metals
Field Duplicates ⁽⁵⁾	10% of sample frequency	2	TCL VOA, TCL SVOA, TCL Pest/PCB, TAL Metals

- Notes:
- (1) QA/QC sample types defined in Section 3.2.4 in text.
 - (2) Trip blanks submitted with coolers which contained samples for volatile analysis. Samples analyzed for TCL Volatiles only.
 - (3) Field blank collected at Site 86 was the source water used for decontamination.
 - (4) Equipment rinsates collected from various sampling equipment (e.g., stainless steel spoons).
 - (5) Field duplicate samples presented in Appendix I.

TABLE 3-4

**SUMMARY OF WELL CONSTRUCTION DETAILS
SITE 86, ABOVE GROUND STORAGE TANK AREA
REMEDIAL INVESTIGATION, CTO-0303
MCAS, NEW RIVER, NORTH CAROLINA**

Well No.	Date Installed	Top of PVC Casing Elevation (feet, above msl) ⁽¹⁾	Ground Surface Elevation (feet, above msl)	Boring Depth (feet, below ground surface)	Well Depth (feet, below ground surface)	Screen Interval Depth (feet, below ground surface)	Sand Pack Interval Depth (feet, below ground surface)	Bentonite Interval Depth (feet, below ground surface)
86-GW15IW	03/09/95	16.56	16.94	57	55	45-55	41-57	33-41
86-GW15DW	03/09/95	16.49	16.83	100	95	90-95	86-100	75-86
86-GW16IW	03/12/95	16.71	16.97	57	55	45-55	42-57	27-42
86-GW16DW	03/11/95	16.82	17.01	95	92	87-92	84-95	75-84
86-GW17IW	03/12/95	17.03	17.20	57	55	45-55	42-57	34-42
86-GW17DW	02/26/95	17.24	17.46	108	106	101-106	99-107	95-99
86-GW18DW	02/24/95	17.89	15.19	113	108	103-108	101-113	94-101
86-GW19DW	03/20/95	18.67	15.77	100	95	90-95	85-100	81-85
86-GW20IW	04/04/95	17.87	15.62	56	55	50-55	40-56	33.5-40
86-GW21IW	05/02/95	18.22	18.57	64	54	44-54	40-55	27-40
86-GW22IW	04/27/95	17.78	18.22	65	64	54-64	49-65	43-49
86-GW23IW	04/26/95	17.36	17.59	65	64	64-64	49-65	46-49
86-GW24	10/12/95	15.15	15.46	66	65.5	55 - 65	51 - 66	37 - 51
85-GW25IW	10/09/95	15.32	15.46	30.5	30.3	20 - 30	18 - 30.5	16 - 18
86-GW26	10/10/95	15.85	16.12	66	65.5	55 - 65	50.5 - 66	26.5 - 50.5
86-GW27IW	10/09/95	15.91	16.12	30.5	30.3	20 - 30	18 - 30.5	16 - 18

Notes: ⁽¹⁾ msl - mean sea level

Horizontal positions are referenced to N.C. State Plane Coordinate System (NAD 27) CF = 0.9999216 from USMC Monument Toney.

Vertical datum NGVD 29.

TABLE 3-5

SUMMARY OF WATER LEVEL MEASUREMENTS
 SITE 86, ABOVE GROUND STORAGE TANK AREA
 REMEDIAL INVESTIGATION, CTO-0303
 MCAS, NEW RIVER, NORTH CAROLINA

Well No.	Top of PVC Casing Elevation (feet, above msl) ⁽¹⁾	Depth to Groundwater (feet, below top of casing)	Depth to Groundwater (feet, below top of casing)	Depth to Groundwater (feet, below top of casing)	Depth to Groundwater (feet, below top of casing)	Groundwater Elevation (feet, above msl)	Groundwater Elevation (feet, above msl)	Groundwater Elevation (feet, above msl)	Groundwater Elevation (feet, above msl)
		March 28, 1995	April 10, 1995	May 10, 1995	August 18, 1995	March 28, 1995	April 10, 1995	May 10, 1995	Aug. 18, 1995
86-GW01	19.39	7.82	8.39	9.36	8.92	11.57	11.00	10.03	10.47
86-GW02IW ⁽³⁾	18.86	7.40	7.92	8.89	8.49	NA	10.94	9.97	10.25
86-GW93	18.20	6.60	7.17	8.13	7.66	11.60	11.03	10.07	10.54
86-GW04IW ⁽³⁾	18.16	6.70	7.20	8.11	7.72	11.46	10.96	10.05	10.44
86-GW05	19.43	8.01	8.55	9.52	NA	11.42	10.88	9.91	NA
86-GW06IW ⁽³⁾	19.21	7.88	8.38	9.33	8.90	11.33	10.83	9.88	10.31
86-GW07	20.14	8.72	9.25	10.21	9.76	11.42	10.89	9.93	10.38
86-GW08IW ⁽³⁾	19.92	8.68	9.17	10.11	9.70	11.24	10.75	9.81	10.22
86-GW09	18.50	7.20	7.72	8.64	8.20	11.30	10.78	9.86	10.30
86-GW10IW ⁽³⁾	17.95	6.72	7.26	6.15	7.78	11.23	10.69	9.80	10.17
86-GW11	19.81	8.32	8.89	9.82	9.36	11.49	10.92	9.99	10.45
86-GW12IW ⁽³⁾	18.74	7.70	8.19	9.14	8.70	11.04	10.55	9.60	10.04
86-GW13	16.88	5.96	6.56	7.60	7.12	10.92	10.32	9.28	9.76
86-GW14IW ⁽³⁾	16.91	6.18	6.66	7.63	NA	10.73	10.25	9.28	NA
86-GW15IW ⁽³⁾	16.56	5.72	6.21	7.08	6.72	10.84	10.35	9.48	9.84
86-GW15DW ⁽³⁾	16.49	5.80	6.27	7.14	6.82	10.69	10.22	9.35	9.67
86-GW16IW ⁽³⁾	16.71	6.38	6.82	7.79	7.38	10.33	9.89	8.92	9.33
86-GW16DW ⁽³⁾	16.82	6.60	7.05	7.99	7.60	10.22	9.77	8.83	9.22
86-GW17IW ⁽³⁾	17.03	5.42	5.92	6.88	6.51	11.61	11.11	10.15	10.52
86-GW17DW ⁽²⁾	17.24	5.71	6.19	7.13	6.80	11.53	11.05	10.11	10.44
86-GW18DW ⁽²⁾	17.89	6.51	7.00	7.92	7.60	11.38	10.89	9.97	10.29
86-GW19DW ⁽²⁾	18.67	7.66	8.17	9.07	8.72	11.01	10.50	9.60	9.95
86-GW20IW ⁽³⁾	17.87	NA	7.10	8.01	7.62	NA	10.77	9.86	10.25

TABLE 3-5 (Continued)

SUMMARY OF WATER LEVEL MEASUREMENTS
 SITE 86, ABOVE GROUND STORAGE TANK AREA
 REMEDIAL INVESTIGATION, CTO-0303
 MCAS, NEW RIVER, NORTH CAROLINA

Well No.	Top of PVC Casing Elevation (feet, above msl) ⁽¹⁾	Depth to Groundwater (feet, below top of casing) March 28, 1995	Depth to Groundwater (feet, below top of casing) April 10, 1995	Depth to Groundwater (feet, below top of casing) May 10, 1995	Depth to Groundwater (feet, below top of casing) August 18, 1995	Groundwater Elevation (feet, above msl) March 28, 1995	Groundwater Elevation (feet, above msl) April 10, 1995	Groundwater Elevation (feet, above msl) May 10, 1995	Groundwater Elevation (feet, above msl) Aug. 18, 1995
86-GW21IW ⁽²⁾	6.06	NA	NA	7.92	7.68	NA	NA	-1.86	10.54
86-GW22IW ⁽²⁾	5.84	NA	NA	8.27	7.93	NA	NA	-2.43	9.85
86-GW23IW ⁽²⁾	6.26	NA	NA	8.57	8.19	NA	NA	-2.31	9.17

Notes: ⁽¹⁾ msl - mean sea level
⁽²⁾ Deep monitoring well
⁽³⁾ Intermediate monitoring well

TABLE 3-6

**SUMMARY OF GROUNDWATER FIELD PARAMETERS
ROUND ONE
SITE 86, ABOVE GROUND STORAGE TANK AREA
REMEDIAL INVESTIGATION, CTO-0303
MCAS, NEW RIVER, NORTH CAROLINA**

Well No.	Depth of Well (ft.) ⁽¹⁾	Purge Volume (gals.)	Field Parameters				
			Well Volume	Specific Conductance at 25°C (micromhos/cm)	Temperature (°C)	pH (S.U.)	Turbidity (T.U.)
86-GW01	17.75	10.2	0	360.0	16.0	5.77	27.2
3/25/95			1.0	348.0	16.0	5.76	56.0
			2.0	330.0	17.0	5.75	32.8
			3.0	330.0	17.0	5.73	20.2
			4.0	330.0	17.0	5.70	11.5
			5.0	310.0	18.0	5.69	7.3
			6.0	316.0	18.0	5.69	4.7
86-GW02IW	32.1	16.8	0	202.0	14.3	5.79	31.5
3/25/95			0.5	204.0	15.9	5.90	28.8
			1.0	232.0	17.0	6.09	120.0
			1.5	315.0	17.1	6.43	75.0
			2.0	365.0	17.0	6.57	33.9
			2.5	434.0	17.1	6.77	16.1
			3.0	447.0	17.8	6.74	8.5
			3.5	465.0	18.0	6.75	5.0
			4.0	481.0	17.9	6.81	3.3
86-GW03	16.61	5.25	0	149.0	18.0	5.41	4.3
3/23/95			1.0	148.0	18.3	5.32	3.0
			2.0	149.0	18.0	5.24	1.5
			3.0	148.0	17.9	5.33	0.9
86-GW04IW	32.45	19.98	0	239.0	20.1	6.27	1.4
3/23/95			1.0	283.0	21.5	6.41	10.5
			2.0	395.0	22.0	6.60	2.1
			3.0	453.0	21.9	6.71	0.9
			4.0	475.0	21.9	6.75	0.9
			4.5	472.0	21.2	6.70	0.7
86-GW05	17.05	8.0	0	261.0	17.0	6.62	12.0
3/24/95			1.0	253.0	17.0	6.69	11.9
			2.0	251.0	17.5	6.64	5.1
			3.0	254.0	18.0	6.66	3.5
			4.0	230.0	18.1	6.69	2.4
			5.0	255.0	18.1	6.70	2.7

TABLE 3-6 (Continued)

SUMMARY OF GROUNDWATER FIELD PARAMETERS
 ROUND ONE
 SITE 86, ABOVE GROUND STORAGE TANK AREA
 REMEDIAL INVESTIGATION, CTO-0303
 MCAS, NEW RIVER, NORTH CAROLINA

Well No.	Depth of Well (ft.) ⁽¹⁾	Purge Volume (gals.)	Field Parameters				
Date of Measurement			Well Volume	Specific Conductance at 25°C (micromhos/cm)	Temperature (°C)	pH (S.U.)	Turbidity (T.U.)
86-GW06IW	32.3	12.6	0	184.0	19.0	6.19	7.2
3/24/95			0.5	180.0	21.5	6.17	11.6
			1.0	182.0	21.0	6.12	17.0
			1.5	174.0	21.9	6.15	10.8
			2.0	178.0	21.0	6.18	6.8
			2.5	180.0	21.2	6.24	4.3
			3.0	206.0	22.0	6.28	3.1
86-GW07	17.68	7.5	0	384	14	5.78	5.1
3/25/95			1.0	390	14	5.84	2.7
			2.0	381	14.5	5.87	1.0
			3.0	384	14	5.88	1.2
			4.0	341	19	5.89	0.7
			5.0	336	19	5.89	0.6
86-GW08IW	32.6	18.45	0	655.0	18.0	7.09	112.1
3/24/95			0.5	616.0	19.0	7.03	59.0
			1.0	610.0	19.5	7.04	134.1
			1.5	610.0	19.5	7.10	66.5
			2.0	690.0	17.5	7.13	29.1
			2.5	683.0	19.0	7.14	16.6
			3.0	683.0	19.0	7.13	11.1
			3.5	672.0	19.0	7.14	7.5
			4.0	683.0	19.0	7.14	5.8
			4.5	701.0	18.0	7.14	4.9
86-GW09	15.0	7.0	0	97.0	18.0	4.56	24.5
3/23/95			1.0	97.0	18.0	4.63	>200.0
			2.0	100.0	17.0	4.66	74.8
			3.0	103.0	18.0	4.71	18.6
			4.0	94.0	17.0	4.68	6.0
			5.0	92.0	18.0	4.70	3.2

TABLE 3-6 (Continued)

SUMMARY OF GROUNDWATER FIELD PARAMETERS
 ROUND ONE
 SITE 86, ABOVE GROUND STORAGE TANK AREA
 REMEDIAL INVESTIGATION, CTO-0303
 MCAS, NEW RIVER, NORTH CAROLINA

Well No.	Depth of Well (ft.) ⁽¹⁾	Purge Volume (gals.)	Field Parameters				
Date of Measurement			Well Volume	Specific Conductance at 25°C (micromhos/cm)	Temperature (°C)	pH (S.U.)	Turbidity (T.U.)
86-GW10IW	31.5	12.72	0	314.0	12.5	5.75	33.1
3/24/95			0.5	330.0	15.0	5.74	21.1
			1.0	325.0	16.0	5.77	27.9
			1.5	355.0	15.0	5.90	11.1
			2.0	341.0	16.9	6.02	4.7
			2.5	3.82	17.0	6.15	2.9
			3.0	390.0	17.0	6.24	1.7
86-GW-11	17.4	13.5	0	600.0	16.0	6.43	>200.0
3/23/95			1.0	720.0	16.0	6.40	>200.0
			2.0	660.0	16.0	6.51	169.2
			3.0	720.0	16.0	6.48	178.1
			4.0	720.0	16.0	6.48	84.0
			5.0	720.0	16.0	6.47	42.6
			6.0	720.0	16.0	6.47	25.3
			7.0	720.0	16.0	6.49	13.0
			8.0	714.0	16.5	6.47	10.4
9.0	720.0	16.0	6.47	6.4			
86-GW12IW	32.9	12.42	0	324.0	21.0	5.64	3.7
3/23/95			0.5	344.0	22.0	5.68	6.2
			1.0	318.0	22.0	5.64	4.2
			1.5	324.0	21.0	5.64	3.5
			2.0	334.0	21.0	5.66	2.7
			2.5	324.0	21.0	5.67	2.0
			3.0	321.0	20.5	5.69	1.8
86-GW13	14.7	9.6	0	239.0	14.0	6.7	4.7
3/23/95			1.0	226.0	14.0	5.84	2.5
			2.0	252.0	14.0	6.09	0.7
			3.0	220.0	14.0	NA	0.3
			4.0	252.0	14.0	NA	0.3
			5.0	225.0	14.5	5.61	0.3
			6.0	220.0	14.0	5.65	0.2

TABLE 3-6 (Continued)

SUMMARY OF GROUNDWATER FIELD PARAMETERS
 ROUND ONE
 SITE 86, ABOVE GROUND STORAGE TANK AREA
 REMEDIAL INVESTIGATION, CTO-0303
 MCAS, NEW RIVER, NORTH CAROLINA

Well No.	Depth of Well (ft.) ⁽¹⁾	Purge Volume (gals.)	Field Parameters				
Date of Measurement			Well Volume	Specific Conductance at 25°C (micromhos/cm)	Temperature (°C)	pH (S.U.)	Turbidity (T.U.)
86-GW14IW	29.8	16.36	0	283.0	19.0	6.94	14.0
3/22/95			1.0	396.0	20.0	6.99	5.0
			2.0	495.0	20.0	6.99	1.4
			3.0	537.0	20.0	6.89	1.1
			4.0	518.0	20.0	7.03	0.6
86-GW15IW	55.0	5.2	0	353.0	24.0	6.95	0.4
3/22/95			0.5	350.0	25.0	6.80	12.7
			1.0	378.0	24.0	6.81	6.3
			1.5	353.0	24.0	6.90	39.5
			2.0	312.0	23.0	6.89	129.0
			2.5	318.0	22.0	6.88	12.0
			3.0	318.0	22.0	6.89	2.8
86-GW15DW	95.5	45.9	0	357.0	22.4	8.68	36.2
3/21/95			0.5	368.0	21.7	8.45	73.5
			0.75	307.0	21.7	8.76	47.4
			1.0	324.0	21.0	8.68	43.1
			1.5	348.0	20.6	8.39	36.6
			2.0	368.0	20.2	8.34	164.3
			2.5	396.0	20.0	8.27	45.9
			3.0	399.0	19.7	8.06	13.5
86-GW16IW	55.5	25.2	0	550.0	20.0	6.86	3.0
3/229/95			0.5	840.0	19.0	6.71	11.5
			1.0	715.0	20.0	6.72	12.7
			1.5	660.0	20.0	6.79	6.5
			2.0	605.0	20.0	6.82	3.1
			2.5	605.0	20.0	6.82	3.3
			3.0	550.0	20.0	6.85	1.9

TABLE 3-6 (Continued)

SUMMARY OF GROUNDWATER FIELD PARAMETERS
 ROUND ONE
 SITE 86, ABOVE GROUND STORAGE TANK AREA
 REMEDIAL INVESTIGATION, CTO-0303
 MCAS, NEW RIVER, NORTH CAROLINA

Well No.	Depth of Well (ft.) ⁽¹⁾	Purge Volume (gals.)	Field Parameters				
Date of Measurement			Well Volume	Specific Conductance at 25°C (micromhos/cm)	Temperature (°C)	pH (S.U.)	Turbidity (T.U.)
86-GW16DW	92.5	79.75	0.5	545.0	20.5	7.7	72.4
3/20/95			1.0	534.0	20.5	8.4	179.0
			1.5	495.0	19.9	9.2	90.0
			2.0	440.0	20.2	8.9	59.6
			2.5	444.0	19.7	8.96	50.4
			3.0	455.0	19.8	8.75	122.3
			3.5	455.0	19.5	8.51	>200.0
			4.0	476.0	19.2	8.33	109.1
			4.5	480.0	19.3	8.34	52.4
			5.0	482.0	19.0	8.29	41.0
			5.5	484.0	19.9	8.25	29.7
86-GW17IW	55.0	46.75	0	580.0	16.9	7.20	8.2
3/23/95			0.5	548.0	19.0	7.32	6.1
			0.75	543.0	19.5	7.26	3.4
			1.0	526.0	19.0	7.26	38.1
			1.5	544.0	20.0	7.26	85.0
			2.0	468.0	20.5	7.28	40.3
			2.5	529.0	21.0	7.29	51.9
			3.0	529.0	21.0	7.30	83.3
			3.5	529.0	21.0	7.25	51.0
			4.0	534.0	20.5	7.29	34.1
			4.5	534.0	20.5	7.31	29.8
			5.0	534.0	20.5	7.35	18.7
			5.5	540.0	21.0	7.34	15.8
86-GW17DW	106.5	51.54	0	683.0	19.0	8.00	6.8
3/21/95			0.5	660.0	19.0	8.90	9.5
			1.0	660.0	19.0	8.95	4.4
			1.5	648.0	21.0	8.73	2.8
			2.0	658.0	21.0	8.69	2.2
			2.5	646.0	22.0	8.62	1.9
			3.0	646.0	22.0	8.63	1.8

TABLE 3-6 (Continued)

SUMMARY OF GROUNDWATER FIELD PARAMETERS
 ROUND ONE
 SITE 86, ABOVE GROUND STORAGE TANK AREA
 REMEDIAL INVESTIGATION, CTO-0303
 MCAS, NEW RIVER, NORTH CAROLINA

Well No.	Depth of Well (ft.) ⁽¹⁾	Purge Volume (gals.)	Field Parameters				
Date of Measurement			Well Volume	Specific Conductance at 25°C (micromhos/cm)	Temperature (°C)	pH (S.U.)	Turbidity (T.U.)
86-GW18DW	108.5	56.23	0	600.0	25.0	6.88	81.3
3/22/95			0.5	600.0	25.0	7.62	86.5
			1.0	600.0	25.0	7.43	66.1
			1.5	600.0	25.0	7.13	46.1
			2.0	600.0	25.0	7.75	28.3
			2.5	610.0	25.0	7.65	23.1
			3.0	610.0	25.0	7.41	17.0
			3.25	610.0	25.0	7.25	15.0
86-GW19DW	95.5	41.4	0	862.0	16.5	7.98	19.9
3/26/95			0.5	472.0	17.0	8.08	66.7
			1.0	404.0	16.5	8.31	37.5
			1.5	377.0	17.0	8.37	29.0
			2.0	448.0	18.0	8.51	14.7
			2.5	448.0	18.0	8.37	9.3
			3.0	452.0	18.9	8.22	5.8
86-GW20IW	56.0	23.43	0.5	515.0	19.0	6.96	8.8
4/11/95			1.0	491.0	19.0	7.06	12.1
			1.5	453.0	19.0	7.10	3.7
			2.0	450.0	19.0	7.10	1.7
			2.5	442.0	19.0	7.12	1.1
			3.0	436.0	19.0	7.16	0.6
86-GW21IW	54.5	23.4	0	431.0	22.9	7.44	1.0
5/7/95			0.5	445.0	22.8	7.35	2.6
			1.0	483.0	23.6	7.19	1.8
			1.5	495.0	24.4	7.36	1.0
			2.0	500.0	23.5	7.43	0.8
			2.5	499.0	24.4	7.45	0.5
			3.0	508.0	23.6	7.44	0.6
86-GW22IW	65.0	28.80	0	367.0	22.2	7.32	3.0
5/7/95			0.5	361.0	22.8	7.37	2.4
			1.0	391.0	21.8	7.30	4.7
			1.5	382.0	22.6	7.31	2.0
			2.0	374.0	23.7	7.33	1.1
			2.5	370.0	23.1	7.37	0.7
			3.0	363.0	24.3	7.46	0.5

TABLE 3-6 (Continued)

SUMMARY OF GROUNDWATER FIELD PARAMETERS
 ROUND ONE
 SITE 86, ABOVE GROUND STORAGE TANK AREA
 REMEDIAL INVESTIGATION, CTO-0303
 MCAS, NEW RIVER, NORTH CAROLINA

Well No.	Depth of Well (ft.) ⁽¹⁾	Purge Volume (gals.)	Field Parameters				
Date of Measurement			Well Volume	Specific Conductance at 25°C (micromhos/cm)	Temperature (°C)	pH (S.U.)	Turbidity (T.U.)
86-GW231W	65.0	28.80	0	397.0	25.4	7.50	0.5
5/7/95			0.5	416.0	23.6	7.46	1.0
			1.0	548.0	23.6	7.48	3.2
			1.5	491.0	23.2	7.53	1.4
			2.0	459.0	23.4	7.53	0.8
			2.5	434.0	23.8	7.52	0.6
			2.75	430.0	23.4	7.54	0.5
			3.0	420.0	23.9	7.55	0.5

Notes: ⁽¹⁾ Well depth taken from top of PVC casing.
 C° - Degrees Centigrade
 S.U. - Standard Units
 T.U. - Turbidity Units

TABLE 3-7

SUMMARY OF GROUNDWATER FIELD PARAMETERS
 ROUND TWO
 SITE 86, ABOVE GROUND STORAGE TANK AREA
 REMEDIAL INVESTIGATION, CTO-0303
 MCAS, NEW RIVER, NORTH CAROLINA

Well No.	Depth of Well (ft.) ⁽¹⁾	Purge Volume (gals.)	Field Parameters				
Date of Measurement			Well Volume	Specific Conductance at 25°C (micromhos/cm)	Temperature (°C)	pH (S.U.)	Turbidity (T.U.)
10/10/95	31.6	4.05	0	143.0	22.0	4.63	4.3
86-GW02			1.0	140.0	22.0	4.85	6.5
			2.0	183.0	21.9	5.09	7.3
			3.0	194.0	21.1	5.17	8.1
			4.0	194.0	21.1	5.25	8.8
			5.0	207.0	21.1	5.32	8.9
			6.0	238.0	21.1	5.43	7.8
			7.0	275.0	21.0	5.58	6.2
			8.0	301.0	21.1	5.71	5.2
			9.0	324.0	21.1	5.79	4.5
			10.0	337.0	21.1	5.88	4.6
			11.0	342.0	22.0	5.87	4.3
			12.0	361.0	21.9	5.97	7.1
			13.0	361.0	21.9	5.96	3.3
14.0	365.0	21.4	6.00	3.1			
10/10/95	30.0	3.90	0	158.0	23.0	5.44	1.3
86-GW04			1.0	159.0	22.0	5.37	2.3
			2.0	178.0	22.0	5.25	0.8
			3.0	181.0	21.8	5.31	0.8
			4.0	180.0	21.5	5.56	0.6
			5.0	195.0	21.5	5.75	0.6
			6.0	268.0	21.5	5.94	0.5
			7.0	256.0	21.5	6.03	0.6
			8.0	322.0	21.5	6.12	0.5
			9.0	302.0	21.0	6.17	0.5
			10.0	359.0	21.5	6.22	0.5
			11.0	366.0	21.5	6.30	0.5
			12.0	327.0	21.5	6.32	0.5
13.0	367.0	21.5	6.33	0.4			

TABLE 3-7 (Continued)

SUMMARY OF GROUNDWATER FIELD PARAMETERS
 ROUND TWO
 SITE 86, ABOVE GROUND STORAGE TANK AREA
 REMEDIAL INVESTIGATION, CTO-0303
 MCAS, NEW RIVER, NORTH CAROLINA

Well No.	Depth of Well (ft.) ⁽¹⁾	Purge Volume (gals.)	Field Parameters				
Date of Measurement			Well Volume	Specific Conductance at 25°C (micromhos/cm)	Temperature (°C)	pH (S.U.)	Turbidity (T.U.)
10/10/95	30.0	3.70	0	130.0	23.0	5.05	0.7
86-GW06			.9	125.0	23.0	5.03	0.8
			1.8	132.0	22.1	5.08	0.7
			2.7	137.0	22.0	5.20	NA
			3.7	143.0	22.0	5.30	NA
			4.6	148.0	21.9	5.31	1.7
			5.5	150.0	21.5	5.31	1.6
			6.4	152.0	21.1	5.33	1.8
			7.4	151.0	21.1	5.35	1.3
			8.3	153.0	21.0	5.34	0.9
			9.2	157.0	21.0	5.36	1.0
			10.0	157.0	21.1	5.36	0.9
10/11/95	30.0	3.87	0	238.0	21.1	4.99	NA
86-GW10			.9	238.0	21.0	4.99	NA
			1.9	293.0	20.9	4.76	NA
			2.9	305.0	20.9	4.65	NA
			3.8	311.0	20.5	4.68	NA
			4.8	314.0	20.9	4.71	NA
			5.8	NA	NA	NA	NA
			6.7	320.0	20.9	4.71	NA
			7.7	321.0	20.5	4.74	NA
			8.7	314.0	20.8	4.76	NA
			10.6	327.0	20.5	4.79	NA
			11.6	328.0	20.8	4.85	NA

TABLE 3-7 (Continued)

SUMMARY OF GROUNDWATER FIELD PARAMETERS
 ROUND TWO
 SITE 86, ABOVE GROUND STORAGE TANK AREA
 REMEDIAL INVESTIGATION, CTO-0303
 MCAS, NEW RIVER, NORTH CAROLINA

Well No.	Depth of Well (ft.) ⁽¹⁾	Purge Volume (gals.)	Field Parameters				
Date of Measurement			Well Volume	Specific Conductance at 25°C (micromhos/cm)	Temperature (°C)	pH (S.U.)	Turbidity (T.U.)
10/11/95	54.40	8.20	0	410.0	25.0	7.00	4.6
86-GW15IW			2.0	413.0	24.0	7.13	4.5
			4.0	408.0	23.9	7.12	11.9
			6.0	441.0	23.1	7.12	17.2
			8.2	434.0	23.5	7.17	5.3
			10.0	427.0	23.1	7.15	1.6
			12.0	427.0	23.1	7.17	1.1
			14.0	417.0	23.1	7.18	0.6
			16.4	416.0	23.0	7.19	0.5
			18.4	415.0	23.0	7.21	0.5
			20.5	408.0	23.0	7.19	0.5
			22.5	411.0	23.0	7.21	0.5
10/11/95	55.27	8.23	0	635.0	22.1	7.27	7.1
86-GW16IW			2.0	637.0	22.0	7.29	6.3
			4.0	644.0	21.5	7.24	9.0
			6.0	804.0	21.5	7.04	20.0
			8.2	761.0	21.5	7.04	11.0
			10.0	756.0	21.1	7.03	5.6
			12.0	648.0	21.0	7.02	3.6
			14.0	638.0	21.0	7.02	2.3
			16.4	638.0	21.0	7.06	1.6
			18.5	638.0	21.0	7.02	1.5
			20.5	638.0	21.0	7.03	1.5
			22.6	638.0	21.0	7.07	1.4

TABLE 3-7 (Continued)

SUMMARY OF GROUNDWATER FIELD PARAMETERS
 ROUND TWO
 SITE 86, ABOVE GROUND STORAGE TANK AREA
 REMEDIAL INVESTIGATION, CTO-0303
 MCAS, NEW RIVER, NORTH CAROLINA

Well No.	Depth of Well (ft.) ⁽¹⁾	Purge Volume (gals.)	Field Parameters				
Date of Measurement			Well Volume	Specific Conductance at 25°C (micromhos/cm)	Temperature (°C)	pH (S.U.)	Turbidity (T.U.)
10/12/95	55.0	8.4	0	531.0	22.0	6.91	0.4
86-GW17IW			2.0	533.0	21.8	6.94	0.2
			4.0	534.0	21.8	6.87	0.2
			6.0	542.0	21.2	6.76	0.7
			8.4	583.0	21.1	6.81	0.7
			10.5	562.0	21.1	6.80	0.3
			12.0	562.0	21.1	6.83	0.4
			14.7	637.0	21.1	6.78	0.3
			16.8	636.0	21.2	6.81	0.4
			18.9	637.0	21.1	6.92	0.4
			21.0	626.0	22.0	6.94	0.6
23.0	626.0	22.0	6.92	0.4			
10/12/95	55.5	8.3	0	473.0	21.5	7.11	0.5
86-GW20IW			2.0	518.0	21.1	7.03	0.9
			4.0	540.0	21.1	7.11	0.6
			6.0	542.0	21.0	7.07	0.2
			8.3	500.0	21.0	7.09	0.7
			10.0	488.0	21.0	7.15	0.7
			12.0	482.0	21.0	7.17	0.5
			14.5	458.0	22.0	7.19	0.9
			16.5	457.0	21.9	7.23	0.3
			18.5	437.0	22.0	7.20	0.4
			20.7	461.0	21.5	7.23	0.3
22.8	440.0	21.5	7.21	0.3			

TABLE 3-7 (Continued)

SUMMARY OF GROUNDWATER FIELD PARAMETERS
 ROUND TWO
 SITE 86, ABOVE GROUND STORAGE TANK AREA
 REMEDIAL INVESTIGATION, CTO-0303
 MCAS, NEW RIVER, NORTH CAROLINA

Well No.	Depth of Well (ft.) ⁽¹⁾	Purge Volume (gals.)	Field Parameters				
Date of Measurement			Well Volume	Specific Conductance at 25°C (micromhos/cm)	Temperature (°C)	pH (S.U.)	Turbidity (T.U.)
10/12/95	54.04	7.97	0	458.0	23.0	7.48	2.9
86-GW21IW			2.0	439.0	23.0	7.33	2.4
			4.0	475.0	22.1	7.25	1.5
			6.0	499.0	23.0	7.39	4.4
			8.0	498.0	23.0	7.32	3.0
			10.0	499.0	23.0	7.31	1.4
			12.0	508.0	22.1	7.30	0.6
			14.0	500.0	22.1	7.36	0.8
			16.0	509.0	22.1	7.36	0.4
			18.0	503.0	22.1	7.32	0.5
			20.0	499.0	21.9	7.01	0.3
22.0	503.0	21.5	7.03	0.5			
10/13/95	64.78	9.80	0	365.0	22.5	7.05	9.1
86-GW22IW			2.5	350.0	21.9	7.11	4.1
			5.0	355.0	21.5	7.17	3.3
			7.4	343.0	21.5	7.21	1.8
			9.8	351.0	21.1	7.21	1.3
			12.3	345.0	21.5	7.24	1.1
			14.7	346.0	21.5	7.25	0.6
			17.0	353.0	21.5	7.31	0.5
			19.6	343.0	21.7	7.30	0.5
			22.0	350.0	21.9	7.36	0.5
			24.5	338.0	22.0	7.38	0.4
27.0	350.0	22.0	7.39	0.7			

TABLE 3-7 (Continued)

SUMMARY OF GROUNDWATER FIELD PARAMETERS
 ROUND TWO
 SITE 86, ABOVE GROUND STORAGE TANK AREA
 REMEDIAL INVESTIGATION, CTO-0303
 MCAS, NEW RIVER, NORTH CAROLINA

Well No.	Depth of Well (ft.) ⁽¹⁾	Purge Volume (gals.)	Field Parameters				
Date of Measurement			Well Volume	Specific Conductance at 25°C (micromhos/cm)	Temperature (°C)	pH (S.U.)	Turbidity (T.U.)
10/13/95	65.49	9.9	0	377.0	24.0	7.44	4.6
86-GW23IW			2.5	389.0	23.9	7.50	5.6
			5.0	374.0	23.0	7.48	3.8
			7.4	414.0	23.0	7.45	3.2
			9.9	389.0	23.0	7.49	1.1
			12.0	393.0	23.0	7.48	0.9
			15.0	354.0	23.0	7.51	1.0
			17.3	374.0	23.0	7.50	0.7
			20.0	373.0	23.0	7.54	0.6
			22.0	364.0	23.0	7.49	0.6
			25.0	365.0	23.0	7.51	0.5
27.0	371.0	22.0	7.52	0.6			
10/15/95	29.57	4.4	0	425.0	22.0	6.28	3.4
86-GW25IW			1.1	392.0	21.0	6.13	3.3
			2.2	497.0	20.9	6.52	5.8
			3.3	519.0	20.0	6.60	5.1
			4.4	519.0	20.0	6.70	4.0
			5.5	520.0	20.0	6.74	4.6
			6.6	522.0	20.0	6.78	5.7
			7.7	529.0	20.0	6.92	5.9
			8.8	518.0	20.1	6.88	5.3
			9.9	514.0	20.5	6.98	4.6
			11.0	518.0	20.1	6.93	3.5
			12.0	522.0	20.0	7.08	2.8
			13.0	484.0	20.1	7.03	2.6
14.0	522.0	20.0	6.97	2.3			

TABLE 3-7 (Continued)

SUMMARY OF GROUNDWATER FIELD PARAMETERS
 ROUND TWO
 SITE 86, ABOVE GROUND STORAGE TANK AREA
 REMEDIAL INVESTIGATION, CTO-0303
 MCAS, NEW RIVER, NORTH CAROLINA

Well No.	Depth of Well (ft.) ⁽¹⁾	Purge Volume (gals.)	Field Parameters				
Date of Measurement			Well Volume	Specific Conductance at 25°C (micromhos/cm)	Temperature (°C)	pH (S.U.)	Turbidity (T.U.)
10/15/95	29.6	4.3	0	510.0	25.0	6.73	16.0
86-GW271W			1.0	710.0	23.5	6.78	6.6
			2.0	906.0	23.5	6.88	16.8
			3.2	906.0	23.5	6.99	23.0
			4.3	906.0	23.5	6.98	10.0
			5.3	866.0	24.0	7.02	5.1
			6.5	875.0	23.5	7.04	2.9
			7.5	884.0	23.0	7.04	1.9
			8.6	823.0	23.5	7.04	1.3
			9.6	323.0	23.5	7.09	1.1
			10.8	829.0	23.2	7.09	1.0
			11.8	832.0	23.0	7.11	0.9
10/16/95	65.0	10.3	0	387.0	20.0	7.46	32.6
86-GW24			2.6	384.0	19.0	7.36	15.4
			5.1	395.0	19.0	7.51	18.3
			7.7	404.0	19.0	7.57	10.6
			10.3	389.0	20.0	7.66	6.0
			13.0	406.0	19.0	7.64	3.4
			15.5	406.0	19.0	7.65	3.1
			18.0	409.0	20.0	7.70	2.2
			21.0	411.0	20.0	7.68	2.0
			23.0	398.0	20.0	7.68	1.4
			26.0	399.0	21.2	7.73	1.1
28.3	390.0	21.0	7.65	1.4			

TABLE 3-7 (Continued)

**SUMMARY OF GROUNDWATER FIELD PARAMETERS
ROUND TWO
SITE 86, ABOVE GROUND STORAGE TANK AREA
REMEDIAL INVESTIGATION, CTO-0303
MCAS, NEW RIVER, NORTH CAROLINA**

Well No.	Depth of Well (ft.) ⁽¹⁾	Purge Volume (gals.)	Field Parameters				
Date of Measurement			Well Volume	Specific Conductance at 25°C (micromhos/cm)	Temperature (°C)	pH (S.U.)	Turbidity (T.U.)
10/16/95	64.8	10.3	0	411.0	22.1	8.25	22.5
86-GW26			2.5	387.0	21.5	7.70	15.2
			5.0	417.0	21.0	7.83	11.0
			7.7	412.0	21.0	7.73	6.5
			10.3	407.0	21.5	6.96	7.0
			13.0	399.0	21.5	7.08	6.6
			15.5	396.0	21.5	7.12	6.4
			18.0	396.0	21.5	7.77	5.2
			21.0	381.0	20.9	7.18	4.0
			23.0	348.0	21.0	7.19	3.3
			26.0	384.0	21.5	7.05	3.4
28.3	382.0	21.9	7.22	3.4			

Notes: ⁽¹⁾ Well depth taken from top of PVC casing.
 C° - Degrees Centigrade
 S.U. - Standard Units
 T.U. - Turbidity Units

TABLE 3-8

**GROUNDWATER SAMPLING SUMMARY
ROUND ONE
SITE 86, ABOVE GROUND STORAGE TANK AREA
REMEDIAL INVESTIGATION, CTO-0303
MCAS, NEW RIVER, NORTH CAROLINA**

Sample Location	Analytical Parameters								
	TCL VOC	TCL SVOC	TCL Pest/ PCB	TAL Metals	Dissolved TAL Metals	TSS	TDS	Duplicate Sample	MS/ MSD
86-GW01	X	X	X	X	X	X	X		
86-GW02IW	X	X		X	X	X	X		
86-GW03	X	X		X		X	X	X	X
86-GW04IW	X	X	X	X		X	X		
86-GW05	X	X	X	X		X	X		
86-GW06IW	X	X		X		X	X		
86-GW07	X	X	X	X		X	X		
86-GW08IW	X	X		X		X	X		
86-GW09	X	X	X	X		X	X		
86-GW10IW	X	X		X		X	X		
86-GW11	X	X		X		X	X		
86-GW12IW	X	X		X		X	X		
86-GW13	X	X		X		X	X		
86-GW14IW	X	X		X		X	X		
86-GW15IW	X	X		X	X	X	X	X	
86-GW15DW	X	X		X	X	X	X		
86-GW16IW	X	X		X		X	X		
86-GW16DW	X	X		X		X	X		
86-GW17IW	X	X		X		X	X		
86-GW17DW	X	X		X		X	X		
86-GW18DW	X	X		X		X	X		
86-GW19DW	X	X		X		X	X		
86-GW20IW	X	X		X		X	X		
86-GW21IW	X			X	X	X	X		
86-GW22IW	X			X		X	X	X	
86-GW23IW	X			X		X	X		

TABLE 3-9

**GROUNDWATER SAMPLING SUMMARY
ROUND TWO
SITE 86, ABOVE GROUND STORAGE TANK AREA
REMEDIAL INVESTIGATION, CTO-0303
MCAS, NEW RIVER, NORTH CAROLINA**

Sample Location	Analytical Parameters		
	TCL VO	Duplicate Sample	MS/MSD
86-GW02IW	X		
86-GW04IW	X		
86-GW06IW	X		
86-GW10IW	X		
86-GW15IW	X		
86-GW16IW	X		
86-GW17IW	X		
86-GW20IW	X	X	X
86-GW21IW	X		
86-GW22IW	X		
86-GW23IW	X		
86-GW24	X		
86-GW25IW	X		
86-GW26	X		
86-GW27JW	X		

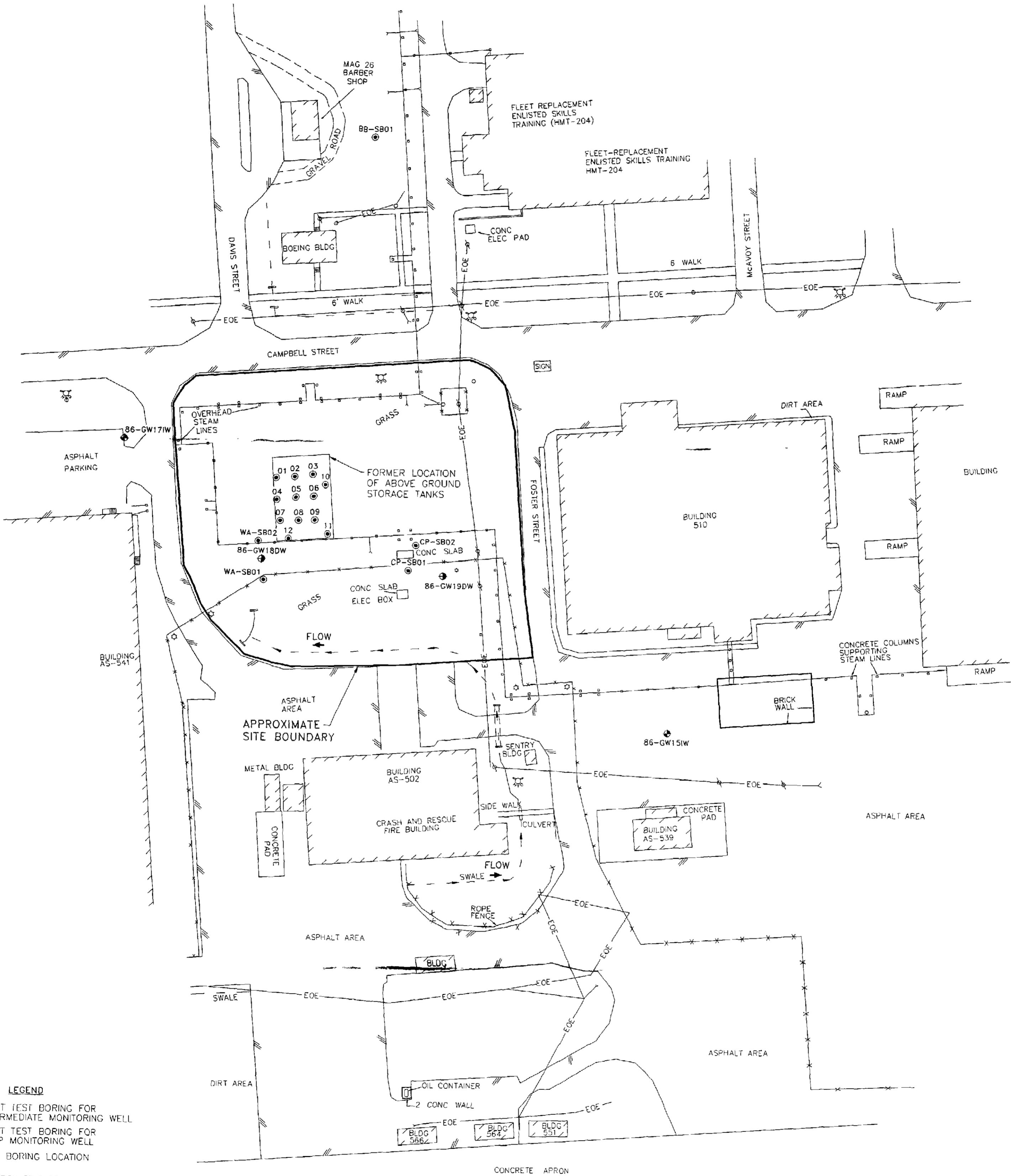
TABLE 3-10

**QUALITY ASSURANCE/QUALITY CONTROL SAMPLING PROGRAM
GROUNDWATER INVESTIGATION
SITE 86 (ABOVE GROUND STORAGE TANK AREA)
REMEDIAL INVESTIGATION, CTO-0303
MCB, CAMP LEJEUNE, NORTH CAROLINA**

QA/QC Sample ⁽¹⁾	Frequency of Collection	Number of Samples	Analytical Parameters
Trip Blanks ⁽²⁾	One per cooler	5	TCL Volatiles
Equipment Rinsates ⁽³⁾	One per day	4	TCL VOA, TCL SVOA, TCL PEST/PCB, TAL Metals, TAL Dissolved Metals
Field Duplicates ⁽⁴⁾	10% of sample frequency	3	TCL, VOA, TCL SVOA, TAL Metals, TAL Dissolved Metals, TSS, TDS

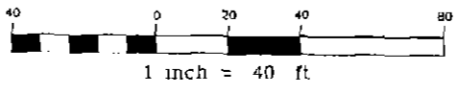
- Notes:
- (1) QA/QC sample types defined in Section 3.3.8 in text.
 - (2) Trip blanks submitted with coolers which contained samples for volatile analysis. Samples analyzed for TCL Volatiles only.
 - (3) Equipment rinsates collected from various sampling equipment (e.g., peristaltic pump).
 - (4) Field duplicate samples presented in Appendix I.

SECTION 3.0 FIGURES



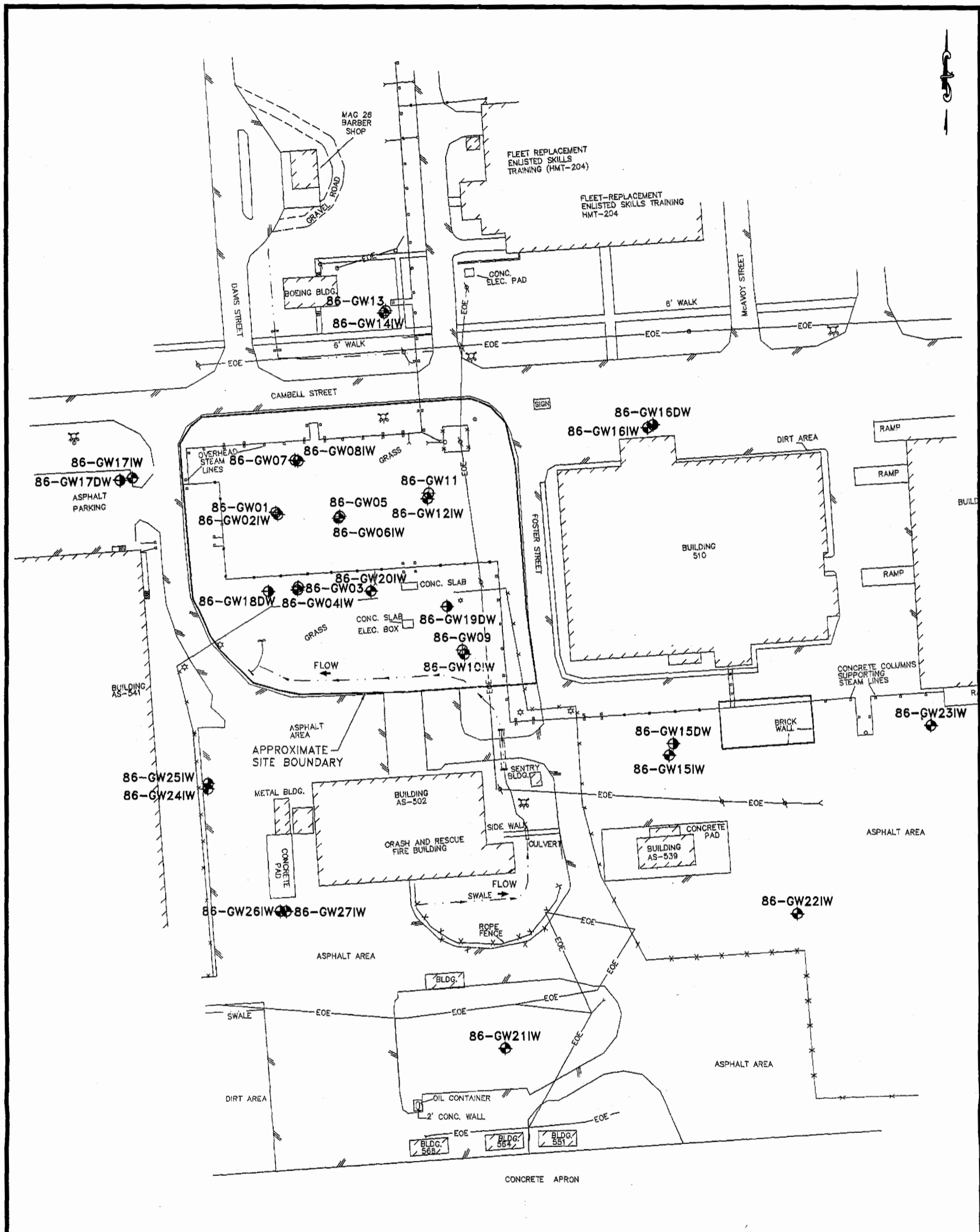
LEGEND

- 86-GW04IW PILOT TEST BORING FOR INTERMEDIATE MONITORING WELL
- 86-GW18DW PILOT TEST BORING FOR DEEP MONITORING WELL
- SB09 SOIL BORING LOCATION
- DIRECTION OF SURFACE WATER FLOW
- EOE— OVERHEAD ELECTRIC LINE & UTILITY POLE
- X—X— FENCE
- //—//— ASPHALT ROAD
- - - - - GRAVEL ROAD
- +—+—+— CENTERLINE OF DRAINAGE SWALE
- LIGHTPOLE
- /— GUY WIRE
- X—X— FIRE HYDRANT
- STRUCTURE



<p>LEGEND</p> <p>SOURCE: LANTON, FEBRUARY 1992 SURVEY: BRENT A. LANIER AND ASSOCIATES, 1995</p>	<p>DRAWN: REL</p> <p>REVIEWED: TFF</p> <p>SO#: 62470-303</p> <p>CADD#: 303048RI</p>	<p>NORTH</p>	<p>REMEDIAL INVESTIGATION CTO-0303 MARINE CORPS AIR STATION, NEW RIVER NORTH CAROLINA</p> <p>BAKER ENVIRONMENTAL, Inc Coraopolis, Pennsylvania</p>	<p>Baker Baker Environmental, Inc</p>	<p>SOIL SAMPLING LOCATIONS SITE 86, ABOVE GROUND TANK STORAGE AREA</p> <p>SCALE: 1" = 40'</p> <p>DATE: JANUARY 1996</p>	<p>FIGURE No 3-1</p>
---	---	--------------	--	--	---	---------------------------------

01719 W 03X

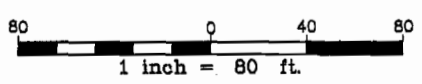


303049R1

LEGEND

86-GW01	SHALLOW MONITORING WELL		
86-GW04IW	INTERMEDIATE MONITORING WELL		
86-GW18DW	DEEP MONITORING WELL		
→	DIRECTION OF SURFACE WATER FLOW		
—EOE—	OVERHEAD ELECTRIC LINE & UTILITY POLE		
—	ASPHALT ROAD		
—	CENTERLINE OF DRAINAGE SWALE	—X—X—	FENCE
☆	LIGHTPOLE	—Y—	GUY WIRE
[Hatched Box]	STRUCTURE	—X—	FIRE HYDRANT

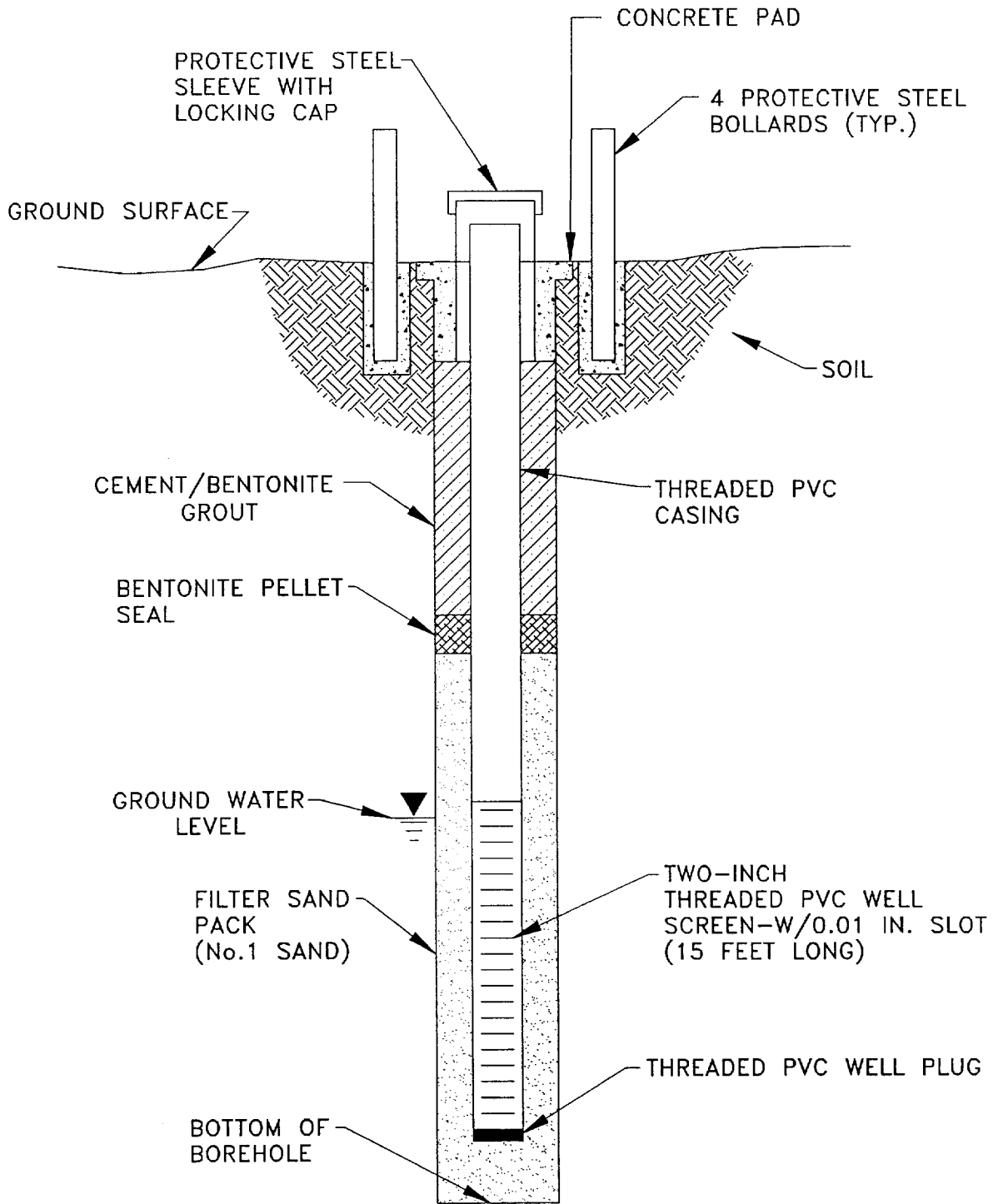
SOURCE: LANTDIV, OCT. 1991



Baker
Baker Environmental, Inc.

3-2
MONITORING WELL LOCATIONS
SITE 86, ABOVE GROUND STORAGE TANK AREA
REMEDIAL INVESTIGATION, CTO-0303
MARINE CORPS AIR STATION, NEW RIVER
CAMP LEJEUNE

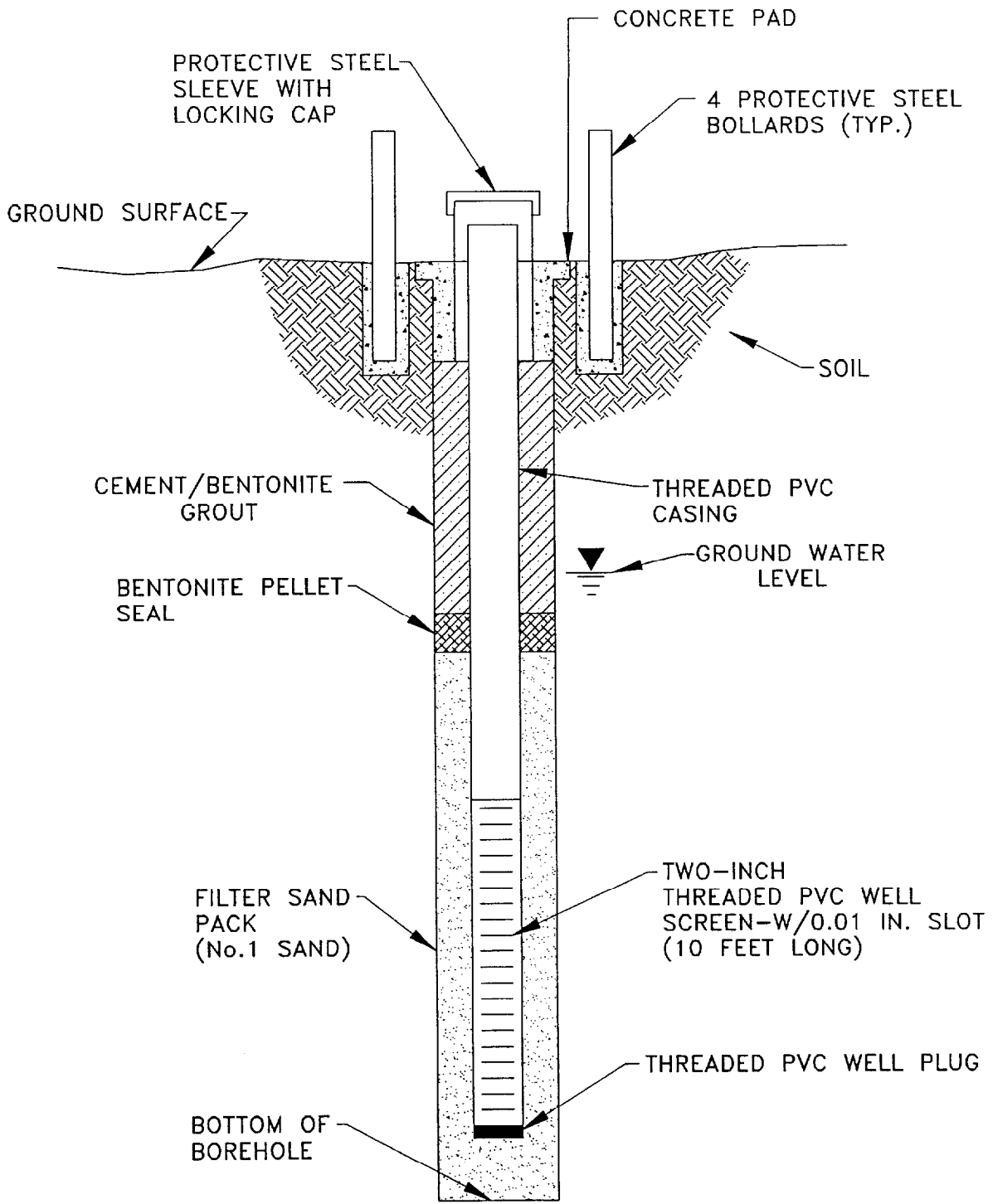
01719W042



N.T.S.



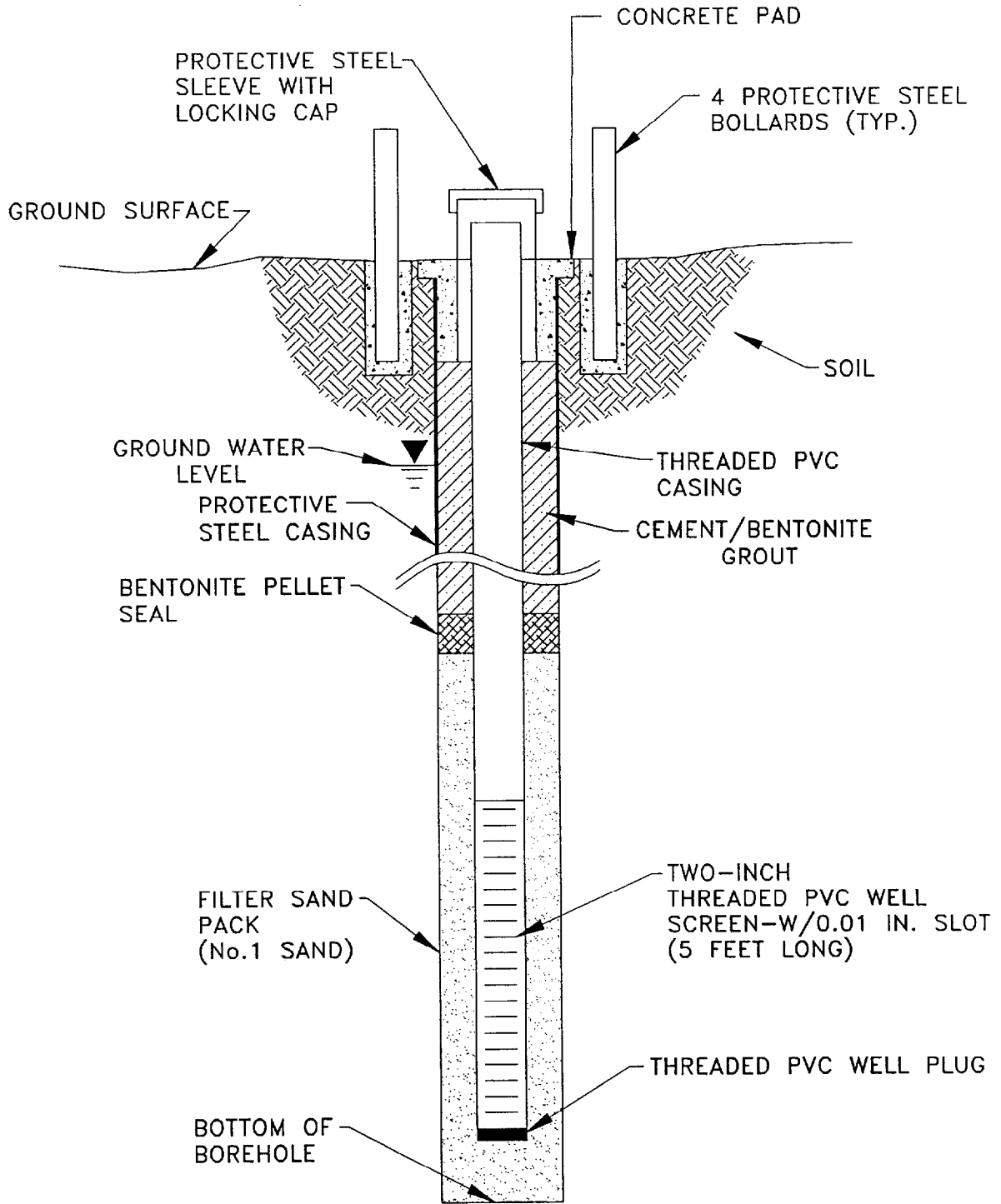
FIGURE 3-3
TYPICAL SHALLOW TYPE II GROUNDWATER
MONITORING WELL CONSTRUCTION DIAGRAM
REMEDIAL INVESTIGATION CTO-0303
MARINE CORPS BASE, CAMP LEJEUNE
NORTH CAROLINA



N.T.S.



FIGURE 3-4
TYPICAL INTERMEDIATE TYPE II GROUNDWATER
MONITORING WELL CONSTRUCTION DIAGRAM
REMEDIAL INVESTIGATION CTO-0303
MARINE CORPS BASE, CAMP LEJEUNE
NORTH CAROLINA



N.T.S.



FIGURE 3-5
TYPICAL DEEP TYPE III GROUNDWATER
MONITORING WELL CONSTRUCTION DIAGRAM
REMEDIAL INVESTIGATION CTO-0303
MARINE CORPS BASE, CAMP LEJEUNE
NORTH CAROLINA

4.0 NATURE AND EXTENT OF CONTAMINATION

This section presents the nature and extent of contamination at OU No. 6, Site 86. The objective of this section is to characterize the nature and extent of any contamination which may be present as a result of past waste management activities. The characterization of contaminants at Site 86 was performed by sampling and laboratory analysis of soil and groundwater environmental media. Appendices G through L present the Sampling Summaries; Data and Frequency Summaries; Statistical Summaries; Field Duplicate Summaries; Quality Assurance and Quality Control Summaries; TCLP and RCRA Results; and Engineering Parameter Results for the various media at Site 86.

4.1 Data Quality

The majority of data generated during the RI was submitted for third-party validation; wet chemistry, TPH, grain size, and permeability results were not validated. The usability of the data was determined by the third party data validator, Heartland Environmental Services, Inc. Procedures stipulated by the National Functional Guidelines for Organic (USEPA, 1991) and Inorganic (USEPA, 1988) Analyses were observed during the validation process. Validation of the analytical data serves to reduce the inherent uncertainties associated with its usability. Data qualified as "J" were retained as estimated. Estimated analytical results within a data set are common and considered to be usable by the USEPA (USEPA, 1989). Data may be qualified as estimated for several reasons including an exceedance of holding times, high or low surrogate recovery or intra-sample variability. In addition, values may be assigned an estimated "J" qualifier if the reported value is below the Contract Required Detection Limit (CRDL) or the Contract Required Quantitation Limit (CRQL). Data assigned a rejected "R" qualifier was excluded from the usable data set. Under these conditions estimated positive results were designated with "J" qualifiers and all rejected data were assigned "R" qualifiers. Table 4-1 provides a summary of all rejected Site 86 data.

Additional qualifiers were employed during the validation of data. The "NJ" qualifier denotes that a compound was tentatively identified, but the reported value may not be accurate or precise. Compounds that were not detected and had inaccurate or imprecise quantitation limits were assigned the "UJ" qualifier.

4.1.1 Data Management and Tracking

The management and tracking of data, from time of field collection to receipt of validation report, is of primary importance to the overall quality of laboratory analytical results. Field samples and their corresponding analyses were recorded on chain-of-custody forms, provided in Appendix C. Chain-of-custody forms were compared to the Field Sampling and Analysis Plan (Baker, 1994); this comparison was used to verify that appropriate laboratory analyses had been requested. Upon receipt of laboratory analytical results, a further comparison was performed to verify that each sample received by the laboratory was analyzed for the correct parameters. Finally, the validation report was compared to the requested laboratory analyses.

The management and tracking of data was used to determine the following items:

- Identify and correct chain-of-custody discrepancies prior to laboratory analysis
- Verify the receipt of all samples by the laboratory
- Confirm that requested sample analyses and validation were performed

- Ensure the delivery of a complete data set

4.2 Non-Site Related Analytical Results

Many of the organic compounds and inorganic analytes detected in environmental media at Site 86 may be attributable to non-site related conditions or activities. Two primary sources of non-site related analytical results include laboratory contaminants and naturally-occurring inorganic species. In addition, non-site related operational activities and conditions may contribute to "on-site" contamination. A discussion of non-site related analytical results for Site 86 is provided in the subsections which follow.

4.2.1 Laboratory Contaminants

Field blank and trip blank samples provide a measure of contamination that has been introduced into a sample set during the collection, transportation, preparation, or analysis of samples. To remove non-site related constituents from further consideration, the concentrations of chemicals detected in blanks were compared with concentrations of the same chemicals detected in environmental samples.

Common laboratory contaminants (i.e., acetone, 2-butanone, chloroform, methylene chloride, toluene, and phthalate esters) were retained for use in interpreting site conditions only when observed concentrations in any environmental sample exceeded ten times the maximum concentration detected in any blank. If the concentration of a common laboratory contaminant was less than ten times the maximum blank concentration its presence among the data set was attributed to laboratory contamination in that particular sample (USEPA, 1989) and excluded from further evaluation. The maximum concentrations of detected common laboratory contaminants in blanks were as follows:

- Acetone 24 J $\mu\text{g/L}$
- Chloroform 13 $\mu\text{g/L}$
- 2-Butanone 32 $\mu\text{g/L}$
- bis-(2-Ethylhexyl)phthalate 280 J $\mu\text{g/L}$

Blanks containing organic constituents that were not considered common laboratory contaminants (i.e., all other TCL compounds) were retained in the site analytical database only when observed concentrations exceeded five times the maximum concentration detected in any QA/QC blank (USEPA, 1989). All TCL compounds detected at less than five times the maximum level of contamination noted in any QA/QC blank were attributed to blank contamination and excluded from further evaluation. The maximum concentrations of all other detected blank contaminants were as follows:

- Bromodichloromethane 13 $\mu\text{g/L}$
- Dibromochloromethane 10 $\mu\text{g/L}$

A limited number of environmental samples that exhibited high concentrations of tentatively identified compounds (TICs) were subjected to an additional sample preparation. Medium level sample preparation provides a corrected Contract Required Quantitation Limit (CRQL) based on the volume of sample used for analysis. The corrected CRQL produces higher detection limits than the

low level sample preparation. A comparison to laboratory blanks used in the medium level preparation was used to evaluate the relative amount of contamination within these samples.

4.2.2 Naturally-Occurring Inorganic Analytes

In order to differentiate between inorganic contamination due to site operations and naturally-occurring inorganic analytes in site media, the results of the sample analyses were compared to information regarding background conditions at MCB Camp Lejeune. The following guidelines were used for each media:

Soil:	MCB Camp Lejeune Background Soil Samples
Groundwater:	MCB Camp Lejeune Background Groundwater Samples
Surface Water:	MCB Camp Lejeune Background Surface Water Samples
Sediment:	MCB Camp Lejeune Background Sediment Samples

The following subsections address the various comparison criteria used to evaluate soil, groundwater, surface water, and sediment analytical results from samples collected at Site 86.

4.2.2.1 Soil

In general, applicable or relevant and appropriate requirements (ARARs) are not available for specific contaminants in soil. As a result, base-specific background concentrations have been compiled from a number of locations throughout MCB Camp Lejeune to evaluate reference levels of inorganic analytes in the surface and subsurface soil.

Typical background concentration values for inorganic analytes in soils at MCB Camp Lejeune are presented in Appendix O. These ranges are based on analytical results of background samples collected in areas not known to have been impacted by operations or disposal activities adjacent to Sites 1, 2, 6, 7, 16, 28, 30, 35, 86, 41, 43, 44, 86, 69, 74, 78, 80, and 86 (refer to Figure 1-2 for site locations throughout MCB Camp Lejeune). Subsequent discussions of the analytical results from samples collected during the soil investigation only consider those inorganic analytes with concentrations exceeding twice the average base-specific background concentration as recommended by USEPA Region IV.

In general, background soil samples have been collected outside the known boundaries of those sites listed above in areas with similar soil types. According to the SCS Soil Survey, the greatest portion of MCB Camp Lejeune is underlain by a number of similar soil units. Soils found on this portion of the coastal plain are moderately to strongly acidic in nature and are classified under the USCS as SM, SM-SP (i.e., fine sand or loamy fine sand). Section 3.0 provides the locations of background soil borings completed at Site 86 during this investigation.

4.2.2.2 Groundwater

Chemical-specific ARARs are available for evaluation of analytical results from groundwater samples. In the subsequent sections which address the analytical results of samples collected during the groundwater investigation, only those inorganic parameters with concentrations exceeding applicable state or federal regulations will be discussed.

Groundwater samples were analyzed for total inorganic parameters. In addition, a limited number of selected groundwater samples were submitted for dissolved (i.e., "filtered") inorganic analyses. Concentrations of dissolved inorganics were found to be generally lower than total inorganic concentrations, particularly for metals such as chromium, iron, lead, and manganese. A 0.45-micron filter was used in the field to remove small particles of silt and clay that would otherwise be dissolved during sample preservation, resulting in higher concentrations of inorganic analytes. The total metal analyses from unfiltered samples is considered to reflect the concentrations of inorganics in the natural lithology and inorganic analytes dissolved in the groundwater.

Higher concentrations of certain metals in unfiltered groundwater samples collected at MCB, Camp Lejeune are not considered atypical based on experience gained during other studies. The difference between the two analytical results (i.e., total and filtered) is important in terms of understanding and separating naturally-occurring elements (e.g., lead) from contamination by site operations (e.g., lead in gasoline). An evaluation report which pertains to naturally occurring metals in groundwater at MCB, Camp Lejeune is provided in Appendix O.

USEPA Region IV requires that unfiltered inorganic concentrations be used in evaluating ARARs and risk to human health and the environment. In the subsequent sections, which discuss the groundwater sample analytical results, both total and dissolved inorganics (which exceed applicable state or federal limits) will be presented and discussed for comparison purposes.

Groundwater in the MCB Camp Lejeune area is naturally rich in iron and manganese. Iron and manganese concentrations, both for total and filtered samples, in groundwater at MCB Camp Lejeune often exceed the North Carolina Water Quality Standards (NCWQS) of 300 and 50 µg/L. Elevated levels of iron and manganese, at concentrations above the NCWQS, were reported in samples collected from a number of base potable water supply wells which are installed at depths greater than 162 feet below ground surface (Greenhorne and O'Mara, 1992). Iron and manganese concentrations from several wells at Site 86 exceeded the NCWQS but fell within the range of concentrations for samples collected elsewhere at MCB Camp Lejeune. There is no record of any historical use of iron or manganese at Site 86. In light of this, it is assumed that iron and manganese are naturally-occurring inorganic analytes in groundwater, and their presence is not attributable to site operations.

4.3 Analytical Results

This section presents the results of the soil and groundwater investigations performed at Site 86. A summary of site contamination, by media, is provided in Table 4-2.

4.3.1 **Soil Investigation**

Unique sample notations were employed to identify soil sampling locations and sample depths at Site 86. Samples designated by "AST," "CP," and "WA" were collected from specific portions of the site (as described in Section 3.0). Samples designated with the prefix "GW" were collected from monitoring well pilot test borings. The following suffix designations refer to the depth at which a sample was obtained:

- 00 - ground surface to 12 inches bgs
- 01 - 1 to 3 feet bgs
- 02 - 3 to 5 feet bgs

- 03 - 5 to 7 feet bgs
- 04 - 7 to 9 feet bgs
- 05 - 9 to 11 feet bgs

Surface soil positive detection summaries for organic compounds and inorganic analytes are presented in Tables 4-3 and 4-4. A positive detection summary of organic compounds in subsurface soils is presented in Table 4-5; a summary of inorganic analytes is provided in Table 4-6. Each soil sample collected at Site 86 was analyzed for TCL volatile and TCL semivolatile organic compounds using CLP protocols and Level IV data quality (refer to Section 3.0). Soil samples obtained from monitoring well test borings were also analyzed for TCL volatile and TCL semivolatile organics. A limited number of surface and subsurface soil samples were also submitted for pesticide, PCB and TAL metal analyses. In addition, soil samples collected at Site 86 were also submitted for TPH analysis (refer to Appendix K).

4.3.1.1 Surface Soil

A total of 18 surface soil samples were collected at Site 86; each sample was analyzed for TCL volatile and TCL semivolatile organic compounds. In addition, 11 of the 18 samples were also submitted for pesticide, PCB, and TAL metal analyses. As indicated in Table 4-2, PCB compounds were not detected in surface soils at Site 86. In addition, results from TPH analyses indicate that no total petroleum hydrocarbons were detected among surface soil samples.

Toluene and total xylenes were each detected once among the 18 surface soil samples obtained from Site 86; no other VOCs were detected. The two positive VOC detections were within and immediately adjacent to the former AST area. As presented in Table 4-2, toluene was detected at a concentration of 25 µg/kg and total xylenes were detected at 5 µg/kg.

A total of 19 semivolatile compounds were detected among 12 of the 18 surface soil samples submitted for laboratory analyses from Site 86. Fifteen of the 19 SVOCs detected were polynuclear aromatic hydrocarbons (PAHs). Concentrations of SVOCs ranged from 37 µg/kg of dibenzo(a,h)anthracene to 3,500 µg/kg of fluoranthene. As presented in Table 4-2, 14 of the 15 PAH compounds were detected at their respective maximum concentration within a surface soil sample obtained from test boring AST-SB11. The PAH compounds fluoranthene, pyrene, benzo(a)anthracene, and benzo(a)pyrene were detected the most frequently, each was identified in at least 9 of the 18 surface soil samples.

Pesticide compounds were detected in each of the 11 surface soil samples submitted for laboratory analyses from Site 86. The pesticides dieldrin, 4,4'-DDE, and 4,4'-DDT were each detected in at least 10 of the 11 samples. Heptachlor epoxide and aldrin were detected only once among the sample set. Lastly, 4,4'-DDD was detected in 5 of the 11 surface soil samples. As indicated in Table 4-2, the compounds 4,4'-DDE, 4,4'-DDT, and 4,4'-DDD were detected at maximum concentrations in samples obtained from the former AST area. Pesticide concentrations ranged from 2 µg/kg of aldrin to 44 µg/kg of dieldrin.

Nineteen of 23 TAL metals were detected among the 11 surface soil samples submitted for laboratory analyses from Site 86 (antimony, beryllium, silver, and thallium were not detected). Table 4-2 provides a summary of the priority pollutant inorganic analytes found within soil samples at Site 86. Priority pollutant metals are a subset of TAL metals which include antimony, arsenic, beryllium, cadmium, chromium, copper, lead, mercury, nickel, selenium, silver, thallium, and zinc.

As provided in Table 4-2, arsenic, cadmium, copper, and mercury were each detected at concentrations exceeding twice their average base-specific (i.e., MCB Camp Lejeune) background levels in fewer than three surface soil samples (refer to Appendix O for base-specific inorganic background concentrations). Chromium, lead, nickel, and zinc were each detected at concentrations exceeding twice their average base-specific background levels in more than five of the surface soil samples. Table 4-2 presents a summary of TAL metals detected among surface soil samples obtained at Site 86.

4.3.1.2 Subsurface Soil

A total of 23 subsurface (i.e., greater than one-foot bgs) soil samples from Site 86 were submitted for laboratory analyses; each sample was analyzed for TCL volatile and semivolatile organic compounds. Sixteen of the 23 samples were also submitted for pesticide, PCB, and TAL metal analyses. Analytical results from these samples indicate the presence of organic compounds and inorganic analytes. However, both TPH and PCB compounds were not detected in any of the subsurface soil samples.

Carbon disulfide, toluene, and total xylenes were detected among the subsurface samples submitted for analyses from Site 86. As provided in Table 4-2, both carbon disulfide and toluene were detected once among the 23 subsurface samples at concentrations of 3 and 250 $\mu\text{g}/\text{kg}$. Total xylenes were detected twice among subsurface samples, both times at a concentration of 5 $\mu\text{g}/\text{kg}$. The four subsurface VOC detections were found in samples obtained from within or immediately adjacent to the former AST area.

Five semivolatile compounds were detected among 6 of the 23 subsurface soil samples obtained at Site 86. Four of the five SVOCs detected were PAH compounds. Concentrations of SVOCs ranged from 42 $\mu\text{g}/\text{kg}$ of chrysene to 300 $\mu\text{g}/\text{kg}$ of butylbenzylphthalate in sample AST-SB11. As provided in Table 4-2, three of the five SVOCs were detected at their respective maximum concentrations within a subsurface soil sample from the pilot test boring 86-GW19DW, located approximately 100 feet to the southeast of the former AST area.

The pesticides 4,4'-DDE, 4,4'-DDD, and 4,4'-DDT were detected in subsurface soil samples that were submitted for analyses from Site 86. Detectable concentrations of organic pesticide compounds were identified in 6 of the 16 subsurface soil samples. Three of the six subsurface samples with pesticide compounds also had positive SVOC detections. As indicated in Table 4-2, the compounds 4,4'-DDE and 4,4'-DDD were each detected five times among surface soil samples. Pesticide concentrations ranged from 1.5 $\mu\text{g}/\text{kg}$ of both 4,4'-DDE and 4,4'-DDT to 36 $\mu\text{g}/\text{kg}$ of 4,4'-DDD.

Eighteen of 23 TAL inorganics were detected in subsurface soil samples obtained at Site 86 (beryllium, cadmium, mercury, silver, and thallium were not detected). As presented in Table 4-2, arsenic, copper, nickel, and zinc were each detected at concentrations exceeding twice their average base-specific background levels in fewer than 5 of the 16 subsurface soil samples submitted for TAL metal analyses. Chromium and lead were detected at maximum concentrations of 34.4 and 16.6 $\mu\text{g}/\text{kg}$. Twelve of the 16 positive lead detections exceeded twice the average base background concentration of 8.3 $\mu\text{g}/\text{kg}$. Nine of the 16 positive chromium detections also exceeded twice the average background concentration of 12.6 $\mu\text{g}/\text{kg}$. None of the other TAL metal detections exceeded twice their average base-specific background levels.

4.3.1.3 Summary

Positive detections of volatile and semivolatile organic compounds were detected in both surface and subsurface soil samples obtained from Site 86. The majority of SVOCs detected in soil samples were PAH compounds. As provided in Table 4-2, several SVOCs were detected at concentrations greater than 500 µg/kg. The maximum VOC concentration was 25 µg/kg of toluene.

Based upon the results of analyses from 11 surface and 16 subsurface soil samples, the pesticides dieldrin, 4,4'-DDE, 4,4'-DDD and 4,4'-DDT appear to be scattered throughout the study area. The pesticide 4,4'-DDE was the most prevalent, with 15 positive detections ranging from 1.5 to 38 µg/kg. The highest pesticide concentration was that of dieldrin at 44 µg/kg. Pesticides were detected in soil samples from Site 86 at low concentrations and without a discernible pattern of dispersal.

Inorganic analytes were detected in both surface and subsurface soil samples at concentrations above twice the average applicable base-specific background levels. Chromium and lead were detected at concentrations above twice their average base-specific background levels in 17 of the 27 soil samples. Other TAL Metals such as arsenic, cadmium, copper, mercury, nickel, and zinc were detected fewer than 10 times above twice their average base-specific background levels. In general, slightly higher concentrations of inorganic analytes were detected in soil samples obtained from within the former AST area.

4.3.2 **Groundwater Investigation**

Groundwater samples from seven existing shallow wells, seven existing intermediate wells, two newly installed shallow wells, nine newly installed intermediate wells, and five newly installed deep wells were submitted for laboratory analyses from Site 86. Samples from each of the 14 existing wells (86-GW01 through 86-GW14IW), 4 of the newly installed intermediate wells (86-GW15IW, 86-GW16IW, 86-GW17IW, and 86-GW20IW), and the 5 newly installed deep wells (86-GW15DW, 86-GW16DW, 86-GW17DW, 86-GW18DW, and 86-GW19DW) were analyzed for TCL volatiles, TCL semivolatiles, TAL total metals, TSS, and TDS. Groundwater samples obtained from three intermediate wells (86-GW21IW, 86-GW22IW, and 86-GW23IW) to the south and southeast of the study area were analyzed for TCL volatiles, TAL metals, TSS, and TDS. In addition, a limited number of groundwater samples were also analyzed for pesticides, PCBs, and TAL dissolved metals. The groundwater samples were analyzed using CLP protocols and Level IV data quality.

During October of 1995 an additional groundwater sampling event was conducted at Site 86 to confirm the presence of volatile organic compounds in the surficial aquifer. During this second sampling event groundwater samples were collected from 11 of the monitoring wells that exhibited volatile contaminants during the initial sampling round. In addition, samples were collected from two newly installed shallow (86-GW25 and 86-GW27) and two newly installed intermediate monitoring wells (86-GW24IW and 86-GW26IW). Each of the 15 samples was submitted for TCL volatiles laboratory analyses only. Tables 4-7 and 4-8 provide summaries of results from both organic and inorganic analyses of samples obtained during the groundwater investigation at Site 86. Pesticide and PCB compounds were not detected in any of groundwater samples obtained from Site 86 and therefore will not be addressed. In addition, no organic compounds were detected in any of the samples obtained from the deep aquifer (i.e., the Castle Hayne aquifer).

4.3.2.1 Shallow Groundwater

Groundwater conditions within the upper and lower portions of the surficial aquifer were evaluated through collection and analysis of samples from both shallow and intermediate monitoring wells at Site 86 (refer to Section 3.0 and Appendix B for well construction details).

Volatile organic compounds were detected in 2 of the 9 shallow monitoring wells and 10 of the 16 intermediate monitoring wells at Site 86. A total of 36 groundwater samples obtained from the surficial aquifer were submitted for laboratory analyses from both the initial and supplemental groundwater sampling events combined. Five VOCs were detected, at varying concentrations, in the groundwater samples obtained from the surficial aquifer.

Trichloroethene and total 1,2-dichloroethene were detected most frequently among the groundwater samples submitted for TCL volatile analyses. As provided in Table 4-2, trichloroethene and total 1,2-dichloroethene were detected at maximum concentrations of 400 and 140 $\mu\text{g/L}$, respectively. Eight positive trichloroethene detections and two positive total 1,2-dichloroethene detections exceeded their applicable MCL standards of 5 and 70 $\mu\text{g/L}$. The VOCs 1,1-dichloroethane, benzene, and tetrachloroethene were also detected among the 36 samples obtained during investigation activities at Site 86. As provided in Table 4-2, maximum concentrations of 1,1-dichloroethane, benzene, and tetrachloroethene were 14, 8, and 77 $\mu\text{g/L}$, respectively. Benzene was detected in 7 of the 36 groundwater samples obtained from the surficial aquifer, at concentrations in excess of the NCWQS of 1 $\mu\text{g/L}$. Tetrachloroethene was detected a total of four times among the Site 86 groundwater samples; each detection exceeded the NCWQS standard of 0.7 $\mu\text{g/L}$. The two positive detections of 1,1-dichloroethene did not exceed the NCWQS standard of 700 $\mu\text{g/L}$. In general, higher positive VOC detections were limited to portions of the surficial aquifer just above the Castle Hayne semi-confining unit.

A total of four SVOCs were detected in 3 of the 23 groundwater samples submitted for TCL semivolatile analyses from Site 86. The maximum SVOC concentration, 23 $\mu\text{g/L}$ of di-n-butylphthalate, was detected in intermediate monitoring well 86-GW17IW located to the west of Site 86 and adjacent to Campbell Street. As provided in Table 4-2, naphthalene, dibenzofuran, and fluorene were each detected once among groundwater samples at concentrations of less than 10 $\mu\text{g/L}$. None of the SVOCs were detected at concentrations in excess of applicable screening standards.

Total metals were detected in each of the samples submitted for TAL analyses from both shallow and intermediate monitoring wells at Site 86. Dissolved metals were also detected among the groundwater samples submitted for filtered analyses. Complete positive detection summaries for total and dissolved metals are provided in Tables 4-8 and 4-9. Twelve of the 23 TAL total metals were detected among the Site 86 groundwater samples (antimony, beryllium, cadmium, chromium, cobalt, copper, mercury, nickel, selenium, silver, and thallium were not detected). Ten of 23 TAL metals were detected among the groundwater samples submitted for dissolved analyses (in addition to the total metals that were not detected; aluminum and vanadium were not detected in the samples submitted for dissolved analyses). Iron and manganese were detected with the greatest frequency among groundwater samples and at concentrations in excess of NCWQS levels, as provided in Table 4-2. Iron exceeded the NCWQS of 300 $\mu\text{g/L}$ in 19 of the 26 groundwater samples obtained from the shallow aquifer at Site 86, with a maximum concentration of 68,300 $\mu\text{g/L}$. Manganese was detected at concentrations exceeding the NCWQS of 50 $\mu\text{g/L}$ in shallow groundwater samples obtained from 15 of the 26 monitoring wells, with a maximum concentration of 416 $\mu\text{g/L}$. Lead was

detected once among the sample set, in well 86-GW06IW, at a concentration of 28.3 µg/L which exceeded the NCWQS of 15 µg/L.

4.3.2.2 Deep Groundwater

A total of five groundwater samples were obtained from the deep aquifer at Site 86. Deep monitoring wells were screened at intervals just below the semi-confining unit and into the upper portion of the Castle Hayne aquifer. Volatile, semivolatile, pesticide, and PCB organic compounds were not detected in any of the five samples obtained from the deep aquifer.

TAL total metals were detected in samples obtained from each of the five deep monitoring wells at Site 86. Nine of the 23 TAL total metals were detected among the five groundwater samples obtained from the Castle Hayne aquifer. As provided in Table 4-9, only one of the five deep aquifer samples was submitted for dissolved metal analyses. Antimony was the only TAL total metal detected among deep groundwater samples in excess of state or federal screening standards. Antimony was detected in well 86-GW16DW at a concentration of 23.6 µg/L that exceeded the MCL of 6 µg/L. None of the other TAL total metals that were detected in deep aquifer samples exceeded either the MCL or the NCWQS standards.

4.3.2.3 Summary

Positive detections of organic compounds were limited to samples obtained from the surficial aquifer. As provided in Table 4-2, seven positive detections of benzene and eight positive detections of trichloroethene exceeded their applicable screening standards of 1 and 5 µg/L. In addition, two detections of total 1,2-dichloroethene and four detections tetrachloroethene were detected at concentrations in excess of their 70 and 0.7 µg/L screening standards.

Inorganics were the most prevalent and widely distributed constituents among groundwater samples obtained at Site 86. Iron and manganese were the most prevalent inorganic analytes detected at concentrations that exceeded state standards in 19 and 15 groundwater samples, respectively. Antimony and lead were each detected once in excess of state or federal screening standards. No other inorganics were detected above applicable screening standards. Table 4-2 presents a summary of inorganic analytes in excess of applicable water quality standards.

4.4 Extent of Contamination

This section addresses the extent of contamination within soil and groundwater at Site 86.

4.4.1 Extent of Soil Contamination

Positive detections of organic compounds in surface and subsurface soil samples collected at Site 86 are depicted on Figures 4-1 and 4-2. Selected TAL metals among surface and subsurface soil samples are depicted on Figures 4-3 and 4-4. The sections which follow detail the presence of both organic compounds and inorganic analytes in soil samples from Site 86. As addressed in Section 4.3.1, PCB compounds and petroleum hydrocarbons were not detected in any of the soil samples submitted for analyses. As a result of those analyses, TPH and PCBs at Site 86 will not be addressed.

4.4.1.1 Volatiles

Volatile organic compounds were detected in two surface and four subsurface soil samples obtained from Site 86. The positive detections were identified in samples from within and immediately adjacent to the former AST area. Total xylenes were detected in one surface and two subsurface samples, each at a concentration of 5 µg/kg. Toluene was detected once among both surface and subsurface soil samples at concentrations of 25 and 250 µg/kg. Carbon disulfide was detected in a single subsurface soil sample at a concentration of 3 µg/kg. The localized occurrence of VOCs among soil samples obtained at Site 86 suggests that their presence is most likely related to past storage and transferal, through ancillary piping, of waste fuel products from the former ASTs.

4.4.1.2 Semivolatiles

Semivolatile organic compounds were identified in both surface and subsurface soil samples obtained from Site 86. The highest positive SVOC detections were limited to samples obtained from the first foot of surface soils. As depicted on Figures 4-1 and 4-2, concentrations of SVOCs varied widely. The concentrations of SVOCs detected in soil samples obtained at Site 86 ranged from 37 µg/kg of dibenzo(a,h)anthracene to 3,500 µg/kg of fluoranthene. The horizontal distribution and concentrations of SVOCs suggests that contaminants may have either migrated via surface water from surrounding paved areas or were the result of fuel spillage. In addition, the majority of Site 86 is used as a contractor staging area for heavy equipment, materials, and vehicles. Exhaust from vehicles and heavy equipment may account for the dispersion of SVOCs throughout Site 86.

4.4.1.3 Pesticides

Positive pesticide detections were observed in both surface and subsurface soil samples throughout Site 86. As Figures 4-1 and 4-2 depict, the detected pesticide levels were low and most likely the result of routine base-wide pesticide application and use. The maximum concentration of any one pesticide detected among the soil samples obtained from Site 86 was that of dieldrin at 44 µg/kg. The frequency and overall concentrations of detected pesticides in soil does not suggest pesticide disposal activities at Site 86.

4.4.1.4 Metals

As addressed in Section 4.3.1 and provided in Table 4-2, a number of samples submitted for analyses had TAL metal concentrations greater than twice their average base-specific background concentration. Inorganic analytes were detected in both surface and subsurface soil samples throughout the study area, as depicted on Figures 4-3 and 4-4. Chromium and lead were detected at concentrations exceeding twice their average base-specific background levels in 17 of the 27 soil samples each. The maximum concentrations of metals in samples obtained from the study area were generally detected in samples obtained from within or immediately adjacent to the former AST area. Although observed concentrations of TAL metals at Site 86 are not indicative of disposal operations or process by-products, elevated detections of metals in samples obtained from the AST area suggests that their presence may correlate to detections of organic compounds.

4.4.2 **Extent of Groundwater Contamination**

Positive detections of organic compounds in groundwater samples collected at Site 86 are depicted on Figure 4-5. Figure 4-6 presents TAL metal sampling results in excess of either federal MCL or

North Carolina WQS levels. As addressed in Section 4.3.2, pesticide and PCB compounds were not detected in any of the groundwater samples submitted for analyses from Site 86. As a result of those analyses, the extent of pesticides and PCBs in groundwater will not be addressed.

4.4.2.1 Volatiles

Positive detections of VOCs were limited to samples obtained from the shallow aquifer. The lack of positive VOC detections in samples obtained from the Castle Hayne aquifer suggests that these contaminants have not migrated vertically from the surficial aquifer. A total of five VOCs were detected among two shallow and ten intermediate monitoring wells at Site 86. The majority of higher volatile detections were observed in samples obtained from intermediate monitoring wells in the central and southeastern portions of the study area; however, at least five monitoring wells located to the northeast and southwest exhibited low concentrations of similar compounds. The highest concentration of a single VOC, trichloroethene at 400 µg/L, was detected in well 86-GW20IW. Monitoring well 86-GW20IW lies within the central portion of the study area, as depicted on Figure 4-5. Four of the five other volatile compounds were detected among the four intermediate wells in that vicinity.

As provided in Table 4-2, a number of positive VOC detections exceeded applicable state or federal screening standards in groundwater samples obtained from the surficial aquifer at Site 86. The maximum VOC concentrations were detected in intermediate wells 86-GW10IW, 86-GW15IW, and 86-GW20IW. Monitoring wells 86-GW10IW and 86-GW20IW are situated in the central and southeastern portion of the study area; 86-GW15IW is located beyond the southeastern boundary of the study area. Each of the three monitoring wells with maximum VOC concentrations are situated within an area surrounded by additional shallow and intermediate monitoring wells. Although VOCs were detected in the surrounding monitoring wells, the concentrations of the observed contaminants were either lower or not detected at all. The dispersion and concentrations of VOCs at Site 86 suggests that a source of these contaminants may have been located within or immediately adjacent to the study area, possibly the former ASTs.

4.4.2.2 Semivolatiles

Semivolatile organic compounds were detected in only 3 of the 23 groundwater samples submitted for laboratory analyses from Site 86. No SVOCs were detected in the five samples obtained below the semi-confining layer which separates the surficial and Castle Hayne aquifers at Site 86.

A total of four semivolatile compounds were detected among samples obtained from one shallow and two intermediate monitoring wells at Site 86 (see Figure 4-5). Three of the four SVOCs were detected at concentrations of less than 10 µg/L. The maximum semivolatile concentration was that of di-n-butylphthalate at 23 µg/L. None of the SVOC detections exceeded applicable water quality standards. As depicted on Figure 4-5, positive detections of semivolatile compounds were limited to the northeastern and southeastern portions of the study area. Based upon laboratory analytical results from the groundwater investigation at Site 86, no apparent pattern of SVOC dispersal is evident.

4.4.2.3 Metals

Inorganic analytes were detected in each of the 26 groundwater samples submitted for total metal analyses from Site 86. Iron and manganese were detected most frequently among the 26

groundwater samples, at levels in excess of either federal MCL or North Carolina WQS (see Figure 4-6). Positive detections of both iron and manganese were distributed throughout the site, indicative of natural site conditions rather than disposal activities. Antimony was detected within a sample obtained from a deep monitoring well at a concentration of 23.6 µg/L which exceeded the NCWQS of 6 µg/L. Lead was detected in only one of the groundwater samples obtained from Site 86. The concentration of lead in the sample obtained from intermediate well 86-GW06IW was 28.3 µg/L, which exceeded the NCWQS of 15 µg/L. In general, higher concentrations of TAL total metal were detected in groundwater samples obtained from the surficial aquifer.

Elevated total metal observations have been recorded at other MCB Camp Lejeune sites and have been attributed as the likely consequence of loose surficial soils. During sampling, a low flow purge method was utilized to minimize the presence suspended solids or colloids in samples that are associated with the surficial soils. The DON is currently evaluating the presence and distribution of total and dissolved metals in groundwater throughout the facility. The draft report entitled "Evaluation of Metals in Groundwater at MCB Camp Lejeune, North Carolina," (provided as Appendix O) addresses the pervasiveness of total metals in groundwater and identifies a number of potential causes. Preliminary conclusions of the study support the opinion that total metal concentrations in groundwater are due more to geologic conditions (i.e., naturally occurring concentrations and unconsolidated soils) and sample acquisition methods than to mobile metal concentrations in the surficial aquifer.

4.5 References

Baker Environmental, Inc. December 1994. Remedial Investigation/Feasibility Study Work Plan for Operable Unit No. 6 (Sites 86, 43, 44, 86, and 86), Marine Corps Base Camp Lejeune, North Carolina. Final. Prepared for the Department of the Navy, Naval Facilities Engineering Command, Atlantic Division, Norfolk, Virginia.

Greenhorne & O'Mara, Inc. 1992. Wellhead Monitoring Study Marine Corps Base, Camp Lejeune, North Carolina. Preliminary Draft. Prepared for Department of the Navy, Naval Facilities Engineering Command, Atlantic Division, Norfolk, Virginia.

United States Environmental Protection Agency (USEPA). 1988. Laboratory Guidelines for Evaluating Inorganics Analysis. Prepared for: Hazardous Site Evaluation Division, U.S. Environmental Protection Agency. Compiled by: Ruth Bleyler. Prepared by: The USEPA Data Review Work Group.

USEPA. 1989. United States Environmental Protection Agency. Risk Assessment Guidance for Superfund Volume II, Environmental Evaluation Manual Interim Final. Office of Solid Waste and Emergency Response. Washington, D.C. EPA/860/1-89-001. May 1989.

USEPA. 1991. National Functional Guidelines for Organic Data Review. Draft. USEPA Contract Laboratory Program.

SECTION 4.0 TABLES

TABLE 4-1

**SUMMARY OF REJECTED DATA
SITE 86, ABOVE GROUND STORAGE TANK AREA
REMEDIAL INVESTIGATION, CTO-0303
MCAS, NEW RIVER, NORTH CAROLINA**

Media	Sample Number	Chemical/Category	Comment
Soils	86-WA-SB01-00	VOCs	1
	86-WA-SB02-00		
Groundwater	86-GW18DW-00	SVOCs	2
	86-GW18DW-00	Zinc	3
	86-GW18DW-02		

Comments:

1. Reject all results except for the D-flagged results that correspond with E-flagged results in the original sample.
2. Reject results due to noncompliant internal standard areas.
3. All non-detect zinc results are rejected because the matrix spike recovery was below 30%.

TABLE 4-2

SUMMARY OF SITE CONTAMINATION
 SITE 86, ABOVE GROUND STORAGE TANK AREA
 REMEDIAL INVESTIGATION, CTO-0303
 MCAS, NEW RIVER, NORTH CAROLINA

Media	Fraction	Detected Contaminants	Comparison Criteria		Site Contamination				
			Standard	Base Background	Min.	Max.	Max. Location	Detection Frequency	Distribution
Surface Soil	Volatiles	Toluene	NA	NA	25	25	86-GW18DW	1/18	former tank area
		Xylene (total)	NA	NA	5	5	AST-SB02	1/18	former tank area
	Semivolatiles	Naphthalene (PAH)	NA	NA	85	85	AST-SB11	1/18	former tank area
		2-Methylnaphthalene	NA	NA	80	80	AST-SB11	1/18	former tank area
		Acenaphthene (PAH)	NA	NA	50	580	AST-SB11	4/18	scattered
		Dibenzofuran	NA	NA	220	220	AST-SB11	1/18	former tank area
		Fluorene (PAH)	NA	NA	43	440	AST-SB11	3/18	scattered
		Phenanthrene (PAH)	NA	NA	64	2,700	AST-SB11	8/18	scattered
		Anthracene (PAH)	NA	NA	43	790	AST-SB11	5/18	scattered
		Carbazole	NA	NA	39	480	AST-SB11	5/18	scattered
		Fluoranthene (PAH)	NA	NA	39	3,500	AST-SB11	9/18	scattered
		Pyrene (PAH)	NA	NA	110	3,100	AST-SB11	10/18	scattered
		Butyl benzyl phthalate	NA	NA	49	380	AST-SB03	4/18	former tank area
		B(a)anthracene (PAH)	NA	NA	70	2,100	AST-SB11	10/18	scattered
		Chrysene (PAH)	NA	NA	86	2,100	AST-SB11	9/18	scattered
		B(b)fluoranthene (PAH)	NA	NA	110	2,300	AST-SB11	8/18	scattered
		B(k)fluoranthene (PAH)	NA	NA	57	950	AST-SB11	8/18	scattered
		Benzo(a)pyrene (PAH)	NA	NA	48	1,800	AST-SB11	10/18	scattered
		I(1,2,3-cd)pyrene (PAH)	NA	NA	67	1,100	AST-SB11	7/18	scattered
		D(a,h)anthracene (PAH)	NA	NA	37	290	AST-SB11	4/18	former tank area
B(g,h,i)perylene (PAH)	NA	NA	57	590	86-GW19DW	7/18	scattered		

TABLE 4-2 (Continued)

SUMMARY OF SITE CONTAMINATION
 SITE 86, ABOVE GROUND STORAGE TANK AREA
 REMEDIAL INVESTIGATION, CTO-0303
 MCAS, NEW RIVER, NORTH CAROLINA

Media	Fraction	Detected Contaminants	Comparison Criteria		Site Contamination				
			Standard	Base Background	Min.	Max.	Max. Location	Detection Frequency	Distribution
Surface Soil (Continued)	Pesticides	Aldrin	NA	NA	2	2	86-GW18DW	1/11	former tank area
		Heptachlor epoxide	NA	NA	5.2	5.2	86-GW19DW	1/11	southeast
		Dieldrin	NA	NA	4.8	44	AST-SB01	10/11	widely scattered, prevalent
		4-4'-DDE	NA	NA	4.9	38	86-GW19DW	11/11	widely scattered, prevalent
		4-4'-DDD	NA	NA	5.2	9.6	AST-SB08	5/11	scattered
		4-4'-DDT	NA	NA	4.3	27	AST-SB08	10/11	widely scattered, prevalent
	PCBs	ND	NA	NA				0/11	
	Metals (1)	Arsenic	NA	1.3	0.5	1.8	AST-SB08	9/11	2 exceed BB, former tank area
		Cadmium	NA	0.7	0.5	1.1	86-GW18DW	5/11	2 exceed BB, former tank area
		Chromium	NA	6.7	5.1	10.1	AST-SB08	11/11	8 exceed BB, former tank area
		Copper	NA	7.2	1.1	53.4	86-GW18DW	10/11	3 exceed BB, former tank area
		Lead	NA	23.7	12.4	43.1	AST-SB03	11/11	5 exceed BB, former tank area
		Mercury	NA	0.1	0.2	0.2	86-GW19DW	1/11	1 exceeds BB, southeast
		Nickel	NA	3.4	1.3	22.3	86-GW19DW	8/11	7 exceed BB, former tank area
Zinc	NA	13.9	5.4	39.9	86-GW18DW	11/11	6 exceed BB, former tank area		
Subsurface Soil	Volatiles	Carbon Disulfide	NA	NA	3	3	WA-SB01	1/23	south of former tank area
		Toluene	NA	NA	250	250	86-GW18DW	1/23	former tank area
		Xylene (total)	NA	NA	5	5	AST-SB07	2/23	former tank area
	Semivolatiles	Fluoranthene (PAH)	NA	NA	62	62	86-GW19DW	1/23	southeast
		Pyrene (PAH)	NA	NA	57	57	86-GW19DW	1/23	southeast
		Butylbenzylphtalate	NA	NA	73	300	AST-SB11	4/23	former tank area
		Chrysene (PAH)	NA	NA	42	140	AST-SB04	2/23	former tank area
		B(b)fluoranthene (PAH)	NA	NA	43	43	86-GW19DW	1/23	southeast

TABLE 4-2 (Continued)

SUMMARY OF SITE CONTAMINATION
 SITE 86, ABOVE GROUND STORAGE TANK AREA
 REMEDIAL INVESTIGATION, CTO-0303
 MCAS, NEW RIVER, NORTH CAROLINA

Media	Fraction	Detected Contaminants	Comparison Criteria		Site Contamination				
			Standard	Base Background	Min.	Max.	Max. Location	Detection Frequency	Distribution
Subsurface Soil (Continued)	Pesticides	4,4'-DDE	NA	NA	1.5	20	AST-SB04	5/16	scattered
		4,4'-DDD	NA	NA	3.2	36	86-GW17IW	5/16	scattered
		4,4'-DDT	NA	NA	1.5	1.5	AST-SB04	1/16	former tank area
	PCBs	ND	NA	NA				0/16	
	Metals (1)	Antimony	NA	6.4	2.2	2.2	86-GW17IW	1/12	does not exceed BB
		Arsenic	NA	1.9	0.3	2.4	AST-SB07	13/16	2 exceed BB, former tank area
		Chromium	NA	12.6	2.4	34.4	AST-SB06	16/16	9 exceed BB, scattered
		Copper	NA	2.4	0.6	7.1	AST-SB04	14/16	5 exceed BB, former tank area
		Lead	NA	8.3	3	16.6	AST-SB06	16/16	12 exceed BB, scattered
		Nickel	NA	3.7	1	28.2	AST-SB05	12/16	4 exceed BB, former tank area
Zinc		NA	6.7	1.3	7.9	AST-SB06	15/16	2 exceed BB, former tank area	
Groundwater	Volatiles	1,1-Dichloroethane	NCWQS - 700	NA	10	14	86-GW10IW	2/41	do not exceed standard
		1,2-Dichloroethene (total)	MCL - 70	NA	3	140	86-GW15IW	14/41	2 exceed standard, southeast
		Trichloroethene	NCWQS - 2.8	NA	2	400	86-GW20IW	13/41	12 exceed standard, south and central
		Benzene	NCWQS -1	NA	2	8	86-GW15IW	7/41	7 exceed standard, south and central
		Tetrachloroethene	NCWQS - 0.7	NA	1	77	86-GW10IW	4/41	4 exceed standard, south and central
	Semivolatiles	Naphthalene (PAH)	NCWQS - 21	NA	6	6	86-GW10IW	1/23	does not exceed standard, southeast
		Dibenzofuran	NA	NA	1	1	86-GW07	1/23	north of former tank area
		Fluorene (PAH)	NCWQS - 280	NA	2	2	86-GW07	1/23	does not exceed standard, north
		Di-n-butylphthalate	NCWQS - 700	NA	23	23	86-GW17IW	1/23	does not exceed standard, west
	Pesticides	ND	NA	NA				0/5	
PCBs	ND	NA	NA				0/5		

TABLE 4-2 (Continued)

**SUMMARY OF SITE CONTAMINATION
SITE 86, ABOVE GROUND STORAGE TANK AREA
REMEDIAL INVESTIGATION, CTO-0303
MCAS, NEW RIVER, NORTH CAROLINA**

Media	Fraction	Detected Contaminants	Comparison Criteria		Site Contamination				
			Standard	Base Background	Min.	Max.	Max. Location	Detection Frequency	Distribution
Groundwater (Continued)	Total Metals	Antimony	MCL - 6	NA	23.6	23.6	86-GW16DW	1/26	1 exceeds standard, east
		Iron	NCWQS - 300	NA	5.1	68,300	86-GW07	23/26	19 exceed standard, scattered
		Lead	NCWQS - 15	NA	28.3	28.3	86-GW06IW	1/26	1 exceeds standard, tank area
		Manganese	NCWQS - 50	NA	3.8	416	86-GW17IW	22/26	15 exceed standard, scattered

Notes:

- Concentrations are presented in $\mu\text{g/L}$ for liquid and $\mu\text{g/Kg}$ for solids (ppb), metal concentrations for soils and sediments are presented in mg/Kg (ppm).

(1) Metals in both surface and subsurface soils were compared to twice the average base background positive concentrations for priority pollutant metals only (i.e., antimony, arsenic, beryllium, cadmium, chromium, copper, lead, mercury, nickel, selenium, silver, thallium, zinc).

ARAR - Applicable or Relevant and Appropriate Requirements

BB - Base background, value equals two times average value for soil (refer to Appendix O)

NA - Not applicable

NCWQS - North Carolina Water Quality Standard

ND - Not detected

NOAA - National Oceanic and Atmospheric Administration

MCL - Federal Maximum Contaminant Level

PAH - Polynuclear aromatic hydrocarbon

TABLE 4-3
SURFACE SOIL - POSITIVE DETECTION SUMMARY
SITE 86, ABOVEGROUND STORAGE TANK AREA
REMEDIAL INVESTIGATION, CTO-0303
MCAS, NEW RIVER, NORTH CAROLINA
TCL ORGANICS

LOCATION	86-AST-SB01-00	86-AST-SB02-00	86-AST-SB03-00	86-AST-SB04-00	86-AST-SB05-00	86-AST-SB06-00
DATE SAMPLED	02/25/95	02/26/95	02/26/95	02/26/95	02/26/95	02/26/95
DEPTH	0-12"	0-12"	0-12"	0-12"	0-12"	0-12"
VOLATILES (ug/kg)						
ACETONE	29 UJ	11 UJ	35 UJ	12 U	11 U	28 J
TOLUENE	12 U	11 UJ	11 U	12 U	11 U	11 U
XYLENE (TOTAL)	12 U	5 J	11 U	12 U	11 U	11 U
SEMIVOLATILES (ug/kg)						
NAPHTHALENE	370 U	370 U	370 U	390 U	380 U	360 U
2-METHYLNAPHTHALENE	370 U	370 U	370 U	390 U	380 U	360 U
ACENAPHTHENE	370 U	370 U	370 U	50 J	380 U	360 U
DIBENZOFURAN	370 U	370 U	370 U	390 U	380 U	360 U
FLUORENE	370 U	370 U	370 U	390 U	380 U	360 U
PHENANTHRENE	370 U	370 UJ	370 U	290 J	380 U	360 U
ANTHRACENE	370 U	370 UJ	370 U	62 J	380 U	360 U
CARBAZOLE	370 U	370 UJ	370 U	43 J	380 U	360 U
FLUORANTHENE	370 U	370 UJ	370 U	310 J	380 U	360 U
PYRENE	370 U	110 J	370 U	260 J	380 U	360 U
BUTYLBENZYLPHTHALATE	300 J	370 UJ	380	390 U	380 U	360 U
BENZO(A)ANTHRACENE	370 U	70 J	370 U	150 J	380 U	360 U
CHRYSENE	370 U	370 UJ	370 U	160 J	380 U	360 U
BIS(2-ETHYLHEXYL)PHTHALATE	370 U	370 UJ	370 U	390 U	380 U	360 U
BENZO(B)FLUORANTHENE	370 U	370 UJ	370 U	180 J	380 U	360 U
BENZO(K)FLUORANTHENE	370 U	370 UJ	370 U	75 J	380 U	360 U
BENZO(A)PYRENE	370 U	48 J	370 U	130 J	380 U	360 U
INDENO(1,2,3-CD)PYRENE	370 U	370 UJ	370 U	88 J	380 U	360 U
DIBENZO(A,H)ANTHRACENE	370 U	370 UJ	370 U	390 U	380 U	360 U
BENZO(G,H,I)PERYLENE	370 U	370 UJ	370 U	78 J	380 U	360 U

UG/KG - microgram per kilogram
J - value is estimated
NA - not analyzed
U - not detected
UJ - not detected, value is estimated

TABLE 4-3
SURFACE SOIL - POSITIVE DETECTION SUMMARY
SITE 86, ABOVEGROUND STORAGE TANK AREA
REMEDIAL INVESTIGATION, CTO-0303
MCAS, NEW RIVER, NORTH CAROLINA
TCL ORGANICS

LOCATION	86-AST-SB01-00	86-AST-SB02-00	86-AST-SB03-00	86-AST-SB04-00	86-AST-SB05-00	86-AST-SB06-00
DATE SAMPLED	02/25/95	02/26/95	02/26/95	02/26/95	02/26/95	02/26/95
DEPTH	0-12"	0-12"	0-12"	0-12"	0-12"	0-12"
PESTICIDE/PCBS (ug/kg)						
ALDRIN	1.9 U	1.8 UJ	1.8 U	2 UJ	1.8 U	1.8 UJ
HEPTACHLOR EPOXIDE	1.9 U	1.8 UJ	1.8 U	2 UJ	1.8 U	1.8 UJ
DIELDRIN	44	35 J	38	8.6 J	32 J	23 J
4,4'-DDE	5.3	6.3 J	9.1	26 J	9.6	6.9 J
4,4'-DDD	3.8 U	8.1 J	3.7 U	8.6 J	3.7 U	3.6 UJ
4,4'-DDT	11	4.4 J	12	20 J	9.2	4.3 J

UG/KG - microgram per kilogram
 J - value is estimated
 NA - not analyzed
 U - not detected
 UJ - not detected, value is estimated

TABLE 4-3
 SURFACE SOIL - POSITIVE DETECTION SUMMARY
 SITE 86, ABOVEGROUND STORAGE TANK AREA
 REMEDIAL INVESTIGATION, CTO-0303
 MCAS, NEW RIVER, NORTH CAROLINA
 TCL ORGANICS

LOCATION	86-AST-SB07-00	86-AST-SB08-00	86-AST-SB09-00	86-AST-SB10-00	86-AST-SB11-00	86-AST-SB12-00
DATE SAMPLED	02/26/95	02/26/95	02/26/95	03/15/95	03/15/95	03/15/95
DEPTH	0-12"	0-12"	0-12"	0-12"	0-12"	0-12"
VOLATILES (ug/kg)						
ACETONE	11 U	11 U	11 U	11 UJ	13 UJ	29 UJ
TOLUENE	11 U	11 U	11 U	11 U	13 U	12 U
XYLENE (TOTAL)	11 U	11 U	11 U	11 U	13 U	12 U
SEMIVOLATILES (ug/kg)						
NAPHTHALENE	370 U	370 U	360 U	370 U	85 J	380 U
2-METHYLNAPHTHALENE	370 U	370 U	360 U	370 U	80 J	380 U
ACENAPHTHENE	370 U	370 U	360 U	370 U	580	380 U
DIBENZOFURAN	370 U	370 U	360 U	370 U	220 J	380 U
FLUORENE	370 U	370 U	360 U	370 U	440	380 U
PHENANTHRENE	370 U	370 U	360 U	64 J	2700	380 U
ANTHRACENE	370 U	370 U	360 U	370 U	790	380 U
CARBAZOLE	370 U	370 U	360 U	370 U	480	380 U
FLUORANTHENE	39 J	370 U	360 U	130 J	3500	380 U
PYRENE	300 J	370 U	360 U	130 J	3100	380 U
BUTYLBENZYLPHTHALATE	370 U	370 U	360 U	49 J	52 J	380 U
BENZO(A)ANTHRACENE	100 J	370 U	360 U	72 J	2100	380 U
CHRYSENE	270 J	370 U	360 U	86 J	2100	380 U
BIS(2-ETHYLHEXYL)PHTHALATE	370 U	370 U	360 U	370 U	47 J	380 U
BENZO(B)FLUORANTHENE	370 U	370 U	360 U	110 J	2300	380 U
BENZO(K)FLUORANTHENE	370 U	370 U	360 U	57 J	950	380 U
BENZO(A)PYRENE	320 J	370 U	360 U	94 J	1800	380 U
INDENO(1,2,3-CD)PYRENE	370 U	370 U	360 U	67 J	1100	380 U
DIBENZO(A,H)ANTHRACENE	370 U	370 U	360 U	370 U	290 J	380 U
BENZO(G,H,I)PERYLENE	370 U	370 U	360 U	57 J	440 U	380 U

UG/KG - microgram per kilogram
 J - value is estimated
 NA - not analyzed
 U - not detected
 UJ - not detected, value is estimated

TABLE 4-3
 SURFACE SOIL - POSITIVE DETECTION SUMMARY
 SITE 86, ABOVEGROUND STORAGE TANK AREA
 REMEDIAL INVESTIGATION, CTO-0303
 MCAS, NEW RIVER, NORTH CAROLINA
 TCL ORGANICS

LOCATION	86-AST-SB07-00	86-AST-SB08-00	86-AST-SB09-00	86-AST-SB10-00	86-AST-SB11-00	86-AST-SB12-00
DATE SAMPLED	02/26/95	02/26/95	02/26/95	03/15/95	03/15/95	03/15/95
DEPTH	0-12"	0-12"	0-12"	0-12"	0-12"	0-12"
PESTICIDE/PCBS (ug/kg)						
ALDRIN	1.9 UJ	1.8 U	1.9 UJ	NA	NA	NA
HEPTACHLOR EPOXIDE	1.9 UJ	1.8 U	1.9 UJ	NA	NA	NA
DIELDRIN	26 J	4.8	13 J	NA	NA	NA
4,4'-DDE	11 J	29 J	24 J	NA	NA	NA
4,4'-DDD	8.9 J	9.6 J	5.2 J	NA	NA	NA
4,4'-DDT	17 J	27 J	23 J	NA	NA	NA

UG/KG - microgram per kilogram
 J - value is estimated
 NA - not analyzed
 U - not detected
 UJ - not detected, value is estimated

TABLE 4-3
SURFACE SOIL - POSITIVE DETECTION SUMMARY
SITE 86, ABOVEGROUND STORAGE TANK AREA
REMEDIAL INVESTIGATION, CTO-0303
MCAS, NEW RIVER, NORTH CAROLINA
TCL ORGANICS

LOCATION	86-CP-SB01-00	86-CP-SB02-00	86-GW18DW-00	86-GW19DW-00	86-WA-SB01-00	86-WA-SB02-00
DATE SAMPLED	05/02/95	05/02/95	02/22/95	03/14/95	05/02/95	05/02/95
DEPTH	0-12"	0-12"	0-12"	0-12"	0-12"	0-12"
VOLATILES (ug/kg)						
ACETONE	12 U	11 U	15 U	12 U	15 UJ	11 U
TOLUENE	12 U	11 U	25	12 UJ	11 UJ	11 UJ
XYLENE (TOTAL)	12 U	11 U	15 U	12 UJ	11 UJ	11 UJ
SEMIVOLATILES (ug/kg)						
NAPHTHALENE	350 U	350 U	490 U	400 U	350 U	350 U
2-METHYLNAPHTHALENE	350 U	350 U	490 U	400 U	350 U	350 U
ACENAPHTHENE	74 J	350 U	490 U	160 J	350 U	350 U
DIBENZOFURAN	350 U	350 U	490 U	400 U	350 U	350 U
FLUORENE	43 J	350 U	490 U	89 J	350 U	350 U
PHENANTHRENE	550	280 J	98 J	970	95 J	350 U
ANTHRACENE	110 J	43 J	490 U	230 J	350 U	350 U
CARBAZOLE	70 J	39 J	490 U	130 J	350 U	350 U
FLUORANTHENE	910	580	180 J	2000	230 J	350 U
PYRENE	990	500	150 J	1400	240 J	350 U
BUTYLBENZYLPHTHALATE	350 U	350 U	490 U	400 U	350 U	350 U
BENZO(A)ANTHRACENE	560	250 J	86 J	960	110 J	350 U
CHRYSENE	620	320 J	110 J	1000	180 J	350 U
BIS(2-ETHYLHEXYL)PHTHALATE	350 U	350 U	86 J	400 U	350 U	350 U
BENZO(B)FLUORANTHENE	730	380	180 J	1200	190 J	350 U
BENZO(K)FLUORANTHENE	310 J	160 J	65 J	510	200 J	350 U
BENZO(A)PYRENE	580	300 J	99 J	980	140 J	350 U
INDENO(1,2,3-CD)PYRENE	400	350 U	77 J	650	110 J	350 U
DIBENZO(A,H)ANTHRACENE	100 J	37 J	490 UJ	150 J	350 U	350 U
BENZO(G,H,I)PERYLENE	400	190 J	72 J	590	110 J	350 U

UG/KG - microgram per kilogram
 J - value is estimated
 NA - not analyzed
 U - not detected
 UJ - not detected, value is estimated

TABLE 4-3
SURFACE SOIL - POSITIVE DETECTION SUMMARY
SITE 86, ABOVEGROUND STORAGE TANK AREA
REMEDIAL INVESTIGATION, CTO-0303
MCAS, NEW RIVER, NORTH CAROLINA
TCL ORGANICS

LOCATION	86-CP-SB01-00	86-CP-SB02-00	86-GW18DW-00	86-GW19DW-00	86-WA-SB01-00	86-WA-SB02-00
DATE SAMPLED	05/02/95	05/02/95	02/22/95	03/14/95	05/02/95	05/02/95
DEPTH	0-12"	0-12"	0-12"	0-12"	0-12"	0-12"
PESTICIDE/PCBS (ug/kg)						
ALDRIN	NA	NA	2 J	2 UJ	NA	NA
HEPTACHLOR EPOXIDE	NA	NA	2.4 UJ	5.2 J	NA	NA
DIELDRIN	NA	NA	29 J	4 UJ	NA	NA
4,4'-DDE	NA	NA	4.9 J	38 J	NA	NA
4,4'-DDD	NA	NA	4.9 UJ	4 UJ	NA	NA
4,4'-DDT	NA	NA	4.9 UJ	5.6 J	NA	NA

UG/KG - microgram per kilogram
 J - value is estimated
 NA - not analyzed
 U - not detected
 UJ - not detected, value is estimated

TABLE 4-4
SURFACE SOIL - POSITIVE DETECTION SUMMARY
SITE 86, ABOVEGROUND STORAGE TANK AREA
REMEDIAL INVESTIGATION, CTO-0303
MCAS, NEW RIVER, NORTH CAROLINA
TAL METALS

LOCATION	86-AST-SB01-00	86-AST-SB02-00	86-AST-SB03-00	86-AST-SB04-00	86-AST-SB05-00	86-AST-SB06-00
DATE SAMPLED	02/25/95	02/26/95	02/26/95	02/26/95	02/26/95	02/26/95
DEPTH	0-12"	0-12"	0-12"	0-12"	0-12"	0-12"
ANALYTES (mg/kg)						
ALUMINUM, TOTAL	4590	4790	5750	5730	6340	4830
ARSENIC, TOTAL	0.69	0.38 U	0.4 U	1.2	0.54	0.53
BARIUM, TOTAL	9.3	9.4	8.5	133	9.5	7.7
CADMIUM, TOTAL	0.54 U	0.62 U	0.57 U	0.53 U	0.63 U	0.57
CALCIUM, TOTAL	19900	1380	1640	8400	2780 J	2800
CHROMIUM, TOTAL	5.6	6.9	6.2	8.9	7.2 J	5.1
COBALT, TOTAL	0.58 U	0.49 U	0.61 U	0.42 U	0.67 U	0.45 U
COPPER, TOTAL	1.8	0.85 U	1.1	3.1	1.5	1.4
IRON, TOTAL	2070	1670	1720	3980	2010	1800
LEAD, TOTAL	38.7	18.7	43.1	14.7 J	14.4	15.9 J
MAGNESIUM, TOTAL	429	157	200	292	250	835
MANGANESE, TOTAL	10.8	5.5	5.8	10.4	14.7 J	7.1
MERCURY, TOTAL	0.08 U	0.11 U	0.11 U	0.12 U	0.09 U	0.079 U
NICKEL, TOTAL	2.1 U	0.9 U	2.2 U	4.3	3.5	1.3
POTASSIUM, TOTAL	249	139	225	226	211	149
SELENIUM, TOTAL	0.35	0.3 U	0.37	0.29 U	0.36 U	0.38
SODIUM, TOTAL	51.4 U	15.9 U	23 U	40.6	42.8	13.7 U
VANADIUM, TOTAL	10.5	7.9	8.3	25.8	12.3	10.4
ZINC, TOTAL	8.3	5.7	5.7	21.9	7.5	18

MG/KG - milligram per kilogram
 J - value is estimated
 U - not detected

TABLE 4-4
 SURFACE SOIL - POSITIVE DETECTION SUMMARY
 SITE 86, ABOVEGROUND STORAGE TANK AREA
 REMEDIAL INVESTIGATION, CTO-0303
 MCAS, NEW RIVER, NORTH CAROLINA
 TAL METALS

LOCATION	86-AST-SB07-00	86-AST-SB08-00	86-AST-SB09-00	86-GW18DW-00	86-GW19DW-00
DATE SAMPLED	02/26/95	02/26/95	02/26/95	02/22/95	03/14/95
DEPTH	0-12"	0-12"	0-12"	0-12"	0-12"
ANALYTES (mg/kg)					
ALUMINUM, TOTAL	5960	6660	6470	5470	5990
ARSENIC, TOTAL	1.1	1.8	1.4	1.1	0.56
BARIUM, TOTAL	43.5	17.3	37.7	13.5	15.8
CADMIUM, TOTAL	0.64	0.84	0.48 U	1.1	0.48
CALCIUM, TOTAL	4280 J	6950 J	4170	3850	4430
CHROMIUM, TOTAL	9 J	10.1 J	9.7	8.7	8.8
COBALT, TOTAL	0.65 U	0.63 U	0.38 U	0.98 U	0.48
COPPER, TOTAL	3.6	8.9	2.1	53.4 J	9.1
IRON, TOTAL	2930	4310	4590	5580	3940
LEAD, TOTAL	21.4	30.7	12.4 J	38.5	33.7
MAGNESIUM, TOTAL	402	681	249	341	363
MANGANESE, TOTAL	11.5 J	11.9 J	8.1	18.5	21.7
MERCURY, TOTAL	0.09 U	0.082 U	0.1 U	0.15 U	0.16
NICKEL, TOTAL	5.2	6.6	3.6	13.4	22.3
POTASSIUM, TOTAL	340	320	202	228	190
SELENIUM, TOTAL	0.37 U	0.37 U	0.29 J	0.69	0.32 U
SODIUM, TOTAL	32.4 U	41.9	31.2 U	41.1	42.7
VANADIUM, TOTAL	18.6	32.4	25.9	56.2	92.7
ZINC, TOTAL	20.1	21	5.4	39.9 J	35.8

MG/KG - milligram per kilogram
 J - value is estimated
 U - not detected

TABLE 4-5
SUBSURFACE SOIL - POSITIVE DETECTION SUMMARY
SITE 86, ABOVEGROUND STORAGE TANK AREA
REMEDIAL INVESTIGATION, CTO-0303
MCAS, NEW RIVER, NORTH CAROLINA
TCL ORGANICS

LOCATION	86-AST-SB01-02	86-AST-SB02-02	86-AST-SB02-05	86-AST-SB03-04	86-AST-SB04-02	86-AST-SB05-03
DATE SAMPLED	02/25/95	02/26/95	02/26/95	02/26/95	02/26/95	02/26/95
DEPTH	3-5'	3-5'	9-11'	7-9'	3-5'	5-7'
VOLATILES (ug/kg)						
ACETONE	12 UJ	50 U	53 J	14 UJ	140	69 U
CARBON DISULFIDE	12 U	12 U	12 U	14 U	12 U	13 U
2-BUTANONE	12 U	12 U	12 U	14 U	12 U	8 J
TOLUENE	12 U	12 U	12 U	14 U	12 U	13 U
XYLENE (TOTAL)	12 U	12 U	5 J	14 U	12 U	13 U
SEMIVOLATILES (ug/kg)						
FLUORANTHENE	400 U	380 U	390 U	470 U	380 U	420 U
PYRENE	400 U	380 U	390 U	470 U	380 U	420 U
BUTYLBENZYLPHthalATE	140 J	380 U	390 U	73 J	380 U	420 U
CHRYSENE	400 U	380 U	390 U	470 U	140 J	420 U
BIS(2-ETHYLHEXYL)PHthalATE	400 U	380 U	390 U	470 U	45 J	860
BENZO(B)FLUORANTHENE	400 U	380 U	390 U	470 U	380 U	420 U
PESTICIDE/PCBS (ug/kg)						
4,4'-DDE	4 U	1.5 J	3.9 UJ	4.7 U	20 J	4.3 U
4,4'-DDD	5.5	4.5 J	3.9 UJ	4.7 U	14 J	4.3 U
4,4'-DDT	4 U	3.8 UJ	3.9 UJ	4.7 U	1.5 J	4.3 U

UG/KG - microgram per kilogram
 J - value is estimated
 NA - not analyzed
 U - not detected
 UJ - not detected, value is estimated

TABLE 4-5
 SUBSURFACE SOIL - POSITIVE DETECTION SUMMARY
 SITE 86, ABOVEGROUND STORAGE TANK AREA
 REMEDIAL INVESTIGATION, CTO-0303
 MCAS, NEW RIVER, NORTH CAROLINA
 TCL ORGANICS

LOCATION	86-AST-SB05-05	86-AST-SB06-04	86-AST-SB07-03	86-AST-SB08-04	86-AST-SB09-04	86-AST-SB10-04
DATE SAMPLED	02/26/95	02/26/95	02/26/95	02/26/95	02/26/95	03/15/95
DEPTH	9-11'	7-9'	5-7'	7-9'	7-9'	7-9'
VOLATILES (ug/kg)						
ACETONE	24 U	54	23 U	29 U	42	54 UJ
CARBON DISULFIDE	12 U	14 U	13 U	12 U	14 U	14 U
2-BUTANONE	12 U	14 U	13 U	12 U	14 U	14 UJ
TOLUENE	12 U	14 U	13 U	12 U	14 U	14 U
XYLENE (TOTAL)	12 U	14 U	5 J	12 U	14 U	14 U
SEMIVOLATILES (ug/kg)						
FLUORANTHENE	410 U	470 U	430 U	410 U	460 U	450 U
PYRENE	410 U	470 U	430 U	410 U	460 U	450 U
BUTYLBENZYLPHTHALATE	410 U	470 U	430 U	410 U	460 U	120 J
CHRYSENE	410 U	470 U	430 U	410 U	460 U	450 U
BIS(2-ETHYLHEXYL)PHTHALATE	970	470 U	430 U	410 U	460 U	450 U
BENZO(B)FLUORANTHENE	410 U	470 UJ	430 U	410 U	460 UJ	450 U
PESTICIDE/PCBS (ug/kg)						
4,4'-DDE	4 U	4.7 UJ	4.3 U	4 U	4.6 UJ	NA
4,4'-DDD	4 U	4.7 UJ	4.3 U	4 U	4.6 UJ	NA
4,4'-DDT	4 U	4.7 UJ	4.3 U	4 U	4.6 UJ	NA

UG/KG - microgram per kilogram
 J - value is estimated
 NA - not analyzed
 U - not detected
 UJ - not detected, value is estimated

TABLE 4-5
 SUBSURFACE SOIL - POSITIVE DETECTION SUMMARY
 SITE 86, ABOVEGROUND STORAGE TANK AREA
 REMEDIAL INVESTIGATION, CTO-0303
 MCAS, NEW RIVER, NORTH CAROLINA
 TCL ORGANICS

LOCATION	86-AST-SB11-03	86-AST-SB12-03	86-CP-SB01-02	86-CP-SB02-02	86-GW15IW-02	86-GW17IW-01
DATE SAMPLED	03/15/95	03/15/95	05/02/95	05/02/95	03/09/95	03/12/95
DEPTH	5-7'	5-7'	3-5'	3-5'	3-5'	1-3'
VOLATILES (ug/kg)						
ACETONE	13 UJ	41 UJ	72	23 U	17 U	250
CARBON DISULFIDE	13 U	13 U	12 U	12 U	12 U	11 U
2-BUTANONE	13 UJ	13 UJ	12 U	12 U	12 U	11 U
TOLUENE	13 U	13 U	12 U	12 U	12 U	11 U
XYLENE (TOTAL)	13 U	13 U	12 U	12 U	12 U	11 U
SEMIVOLATILES (ug/kg)						
FLUORANTHENE	430 U	430 U	400 U	400 U	410 U	360 U
PYRENE	430 U	430 U	400 U	400 U	410 U	360 U
BUTYLBENZYLPHthalATE	300 J	430 U	400 U	400 U	410 U	360 U
CHRYSENE	430 U	430 U	400 U	400 U	410 U	360 U
BIS(2-ETHYLHEXYL)PHTHALATE	430 U	430 U	400 U	400 U	1100 U	360 U
BENZO(B)FLUORANTHENE	430 U	430 U	400 U	400 U	410 U	360 U
PESTICIDE/PCBS (ug/kg)						
4,4'-DDE	NA	NA	NA	NA	4 U	11 J
4,4'-DDD	NA	NA	NA	NA	4 U	36 J
4,4'-DDT	NA	NA	NA	NA	4 U	3.7 UJ

UG/KG - microgram per kilogram
 J - value is estimated
 NA - not analyzed
 U - not detected
 UJ - not detected, value is estimated

TABLE 4-5
SUBSURFACE SOIL - POSITIVE DETECTION SUMMARY
SITE 86, ABOVEGROUND STORAGE TANK AREA
REMEDIAL INVESTIGATION, CTO-0303
MCAS, NEW RIVER, NORTH CAROLINA
TCL ORGANICS

LOCATION	86-GW17IW-02	86-GW18DW-02	86-GW19DW-02	86-WA-SB01-02	86-WA-SB02-03
DATE SAMPLED	03/12/95	02/22/95	03/14/95	05/02/95	05/02/95
DEPTH	3-5'	3-5'	3-5'	3-5'	5-7'
VOLATILES (ug/kg)					
ACETONE	82 U	40	11 U	15 U	120
CARBON DISULFIDE	12 U	13 U	11 U	3 J	15 U
2-BUTANONE	12 U	13 U	11 U	15 U	15 U
TOLUENE	12 U	250	11 U	15 U	15 U
XYLENE (TOTAL)	12 U	13 U	11 U	15 U	15 U
SEMIVOLATILES (ug/kg)					
FLUORANTHENE	400 U	430 U	62 J	480 U	500 U
PYRENE	400 U	430 U	57 J	480 U	500 U
BUTYLBENZYLPHthalate	400 U	430 U	380 U	480 U	500 U
CHRYSENE	400 U	430 U	42 J	480 U	500 U
BIS(2-ETHYLHEXYL)PHthalate	400 U	120 J	320 J	480 U	500 U
BENZO(B)FLUORANTHENE	400 U	430 U	43 J	480 U	500 U
PESTICIDE/PCBS (ug/kg)					
4,4'-DDE	4 J	4.3 UJ	3.4 J	NA	NA
4,4'-DDD	3.2 J	4.3 UJ	3.8 UJ	NA	NA
4,4'-DDT	4 UJ	4.3 UJ	3.8 UJ	NA	NA

UG/KG - microgram per kilogram
 J - value is estimated
 NA - not analyzed
 U - not detected
 UJ - not detected, value is estimated

TABLE 4-6
 SUBSURFACE SOIL - POSITIVE DETECTION SUMMARY
 SITE 86, ABOVEGROUND STORAGE TANK AREA
 REMEDIAL INVESTIGATION, CTO-0303
 MCAS, NEW RIVER, NORTH CAROLINA
 TAL METALS

LOCATION	86-AST-SB01-02	86-AST-SB02-02	86-AST-SB02-05	86-AST-SB03-04	86-AST-SB04-02	86-AST-SB05-03
DATE SAMPLED	02/25/95	02/26/95	02/26/95	02/26/95	02/26/95	02/26/95
DEPTH	3-5'	3-5'	9-11'	7-9'	3-5'	5-7'
ANALYTES (mg/kg)						
ALUMINUM, TOTAL	10900	10800	6860	19400	3950	12500
ANTIMONY, TOTAL	4 UJ	1.8 UJ	1.8 UJ	5.6 UJ	2.1 UJ	4.4 R
ARSENIC, TOTAL	0.93	0.82	1.3	1.1 J	0.59	1.6
BARIUM, TOTAL	22	15.3	19.3	26.2	9.7	14.8
CALCIUM, TOTAL	1050	672	2110	325	10300	1200 J
CHROMIUM, TOTAL	11.6	10.7	9.7	29.3	5.9	17.3 J
COBALT, TOTAL	0.58 U	0.56	0.38 U	0.81 U	0.45 U	0.64 U
COPPER, TOTAL	1.3	0.81	2.2	4	7.1	0.55
IRON, TOTAL	5620	9250	3210	6700	3430	10900
LEAD, TOTAL	10	13.2	5.7	15.9	10.2	9
MAGNESIUM, TOTAL	443	303	228	796	291	470
MANGANESE, TOTAL	11.2	6.6	5.3	10.3	10.4	8.3 J
NICKEL, TOTAL	2.1 U	1.9	11.2	2.9 U	2.7	3.3
POTASSIUM, TOTAL	426	208	241	1050	131	352
SELENIUM, TOTAL	0.35 U	0.34 U	0.35	0.41	0.3 U	0.41 U
SODIUM, TOTAL	90.2	147	128	145	39.5 U	130
VANADIUM, TOTAL	15.9	19.2	11.1	32.7	17	23.1
ZINC, TOTAL	3	2.5 U	3.2	4.7	7.6	4.1

MG/KG - milligram per kilogram
 J - value is estimated
 R - rejected
 U - not detected
 UJ - not detected, value is estimated

TABLE 4-6
SUBSURFACE SOIL - POSITIVE DETECTION SUMMARY
SITE 86, ABOVEGROUND STORAGE TANK AREA
REMEDIAL INVESTIGATION, CTO-0303
MCAS, NEW RIVER, NORTH CAROLINA
TAL METALS

LOCATION	86-AST-SB05-05	86-AST-SB06-04	86-AST-SB07-03	86-AST-SB08-04	86-AST-SB09-04	86-GW15IW-02
DATE SAMPLED	02/26/95	02/26/95	02/26/95	02/26/95	02/26/95	03/09/95
DEPTH	9-11'	7-9'	5-7'	7-9'	7-9'	3-5'
ANALYTES (mg/kg)						
ALUMINUM, TOTAL	11900	24900	13500	10900	9450	12200
ANTIMONY, TOTAL	4.8 R	2.7 UJ	4.6 R	4.4 R	2.8 UJ	4.5 UJ
ARSENIC, TOTAL	1.7 J	0.47 U	2.4	1.8	0.54	0.27 J
BARIUM, TOTAL	16.5	32.8	19.6	14.6	17.6	19.7
CALCIUM, TOTAL	1480 J	152	2130 J	140 J	51.9	4090
CHROMIUM, TOTAL	14.3 J	34.4	18.2 J	13.1 J	15.8	10.8
COBALT, TOTAL	1.2	1.2	0.67 U	0.63 U	0.7	0.65 U
COPPER, TOTAL	3.5	3.1	1.5	0.99	2.6	0.41 U
IRON, TOTAL	9580	5630	8820	9860	2090	7620
LEAD, TOTAL	8.7	16.6 J	10.9	8.3	11.3	10.3
MAGNESIUM, TOTAL	439	925	545	337	310	403
MANGANESE, TOTAL	8.9 J	12.3	10.2 J	6.5 J	8.5	7.1
NICKEL, TOTAL	28.2	3.7	4.5	5.3	1.9	2.4 U
POTASSIUM, TOTAL	287	1120	507	353	428	288
SELENIUM, TOTAL	0.42 U	0.37 U	0.39 U	0.34 U	0.38 U	0.35 U
SODIUM, TOTAL	111	112	71.8	81.3	45.3	48.4 U
VANADIUM, TOTAL	21.7	32.4	27.5	20.7	12.1	17.3
ZINC, TOTAL	5.1	7.9	5.4	2.5	3.5	5.8

MG/KG - milligram per kilogram
 J - value is estimated
 R - rejected
 U - not detected
 UJ - not detected, value is estimated

TABLE 4-6
 SUBSURFACE SOIL - POSITIVE DETECTION SUMMARY
 SITE 86, ABOVEGROUND STORAGE TANK AREA
 REMEDIAL INVESTIGATION, CTO-0303
 MCAS, NEW RIVER, NORTH CAROLINA
 TAL METALS

LOCATION	86-GW17IW-01	86-GW17IW-02	86-GW18DW-02	86-GW19DW-02
DATE SAMPLED	03/12/95	03/12/95	02/22/95	03/14/95
DEPTH	1-3'	3-5'	3-5'	3-5'
ANALYTES (mg/kg)				
ALUMINUM, TOTAL	2140	10400	12200	2940
ANTIMONY, TOTAL	2.2 UJ	2.2 J	4.2 UJ	2 UJ
ARSENIC, TOTAL	0.32 U	0.81	2.3	0.41 U
BARIUM, TOTAL	3.7	16.9	19.7	5.1
CALCIUM, TOTAL	1860	2650	466	530
CHROMIUM, TOTAL	2.4	12.6	14.9	8.7
COBALT, TOTAL	0.46 U	0.39	0.6 U	0.42 U
COPPER, TOTAL	0.79 U	2.3	0.94 J	2.1
IRON, TOTAL	938	4780	7860	1950
LEAD, TOTAL	3	7.7	12.3	4.1
MAGNESIUM, TOTAL	62.6	244	318	79.6
MANGANESE, TOTAL	2.1	5.5	3.6	6.4
NICKEL, TOTAL	0.95	1.4	2.2 U	1.4
POTASSIUM, TOTAL	88.1	275	257	48
SELENIUM, TOTAL	0.4 UJ	0.34 UJ	0.59	0.33 U
SODIUM, TOTAL	29.5	37	44.1	26.5 U
VANADIUM, TOTAL	3.1	17.5	19	4.7
ZINC, TOTAL	1.3	2.6	2.5	1.7

MG/KG - milligram per kilogram
 J - value is estimated
 R - rejected
 U - not detected
 UJ - not detected, value is estimated

TABLE 4-7
GROUNDWATER - POSITIVE DETECTION SUMMARY
SITE 86, ABOVEGROUND STORAGE TANK AREA
REMEDIAL INVESTIGATION, CTO-0303
MCAS, NEW RIVER, NORTH CAROLINA
TCL ORGANICS

LOCATION	86-GW01-01	86-GW02IW-01	86-GW03-01	86-GW04IW-01	86-GW05-01	86-GW06IW-01
DATE SAMPLED	03/25/95	03/25/95	03/23/95	03/23/95	03/24/95	03/24/95
VOLATILES (ug/l)						
1,1-DICHLOROETHANE	10 U	10 U	10 U	10 U	10 U	10 U
1,2-DICHLOROETHENE (TOTAL)	10 U	10 U	10 U	19	10 U	10 U
TRICHLOROETHENE	10 U	10 U	10 U	24	10 U	10 U
BENZENE	10 U	10 U	10 U	10 U	10 U	10 U
TETRACHLOROETHENE	10 U	10 U	10 U	10 U	10 U	10 U
SEMIVOLATILES (ug/l)						
NAPHTHALENE	10 U	10 U	10 U	10 U	10 U	10 U
DIBENZOFURAN	10 U	10 U	10 U	10 U	10 U	10 U
FLUORENE	10 U	10 U	10 U	10 U	10 U	10 U
DI-N-BUTYLPHTHALATE	10 U	10 U	10 U	10 U	10 U	10 U

UG/L - microgram per liter
J - value is estimated
NA - not analyzed
U - not detected
UJ - not detected, value is estimated

TABLE 4-7
GROUNDWATER - POSITIVE DETECTION SUMMARY
SITE 86, ABOVEGROUND STORAGE TANK AREA
REMEDIAL INVESTIGATION, CTO-0303
MCAS, NEW RIVER, NORTH CAROLINA
TCL ORGANICS

LOCATION	86-GW07-01	86-GW08IW-01	86-GW09-01	86-GW10IW-01	86-GW11-01	86-GW12IW-01
DATE SAMPLED	03/25/95	03/24/95	03/23/95	03/24/95	03/23/95	03/23/95
VOLATILES (ug/l)						
1,1-DICHLOROETHANE	10 U	10 U	10 U	14	10 U	10 U
1,2-DICHLOROETHENE (TOTAL)	10 U	10 U	10 U	23	10 U	10 U
TRICHLOROETHENE	10 U	10 U	10 U	27	10 U	10 U
BENZENE	10 U	10 U	10 U	10 U	10 U	10 U
TETRACHLOROETHENE	10 U	10 U	10 U	77	10 U	10 U
SEMIVOLATILES (ug/l)						
NAPHTHALENE	10 U	10 U	10 U	6 J	9 U	10 U
DIBENZOFURAN	1 J	10 U	10 U	10 U	9 U	10 U
FLUORENE	2 J	10 U	10 U	10 U	9 U	10 U
DI-N-BUTYLPHTHALATE	10 U	10 U	10 U	10 U	9 U	10 U

UG/L - microgram per liter
 J - value is estimated
 NA - not analyzed
 U - not detected
 UJ - not detected, value is estimated

TABLE 4-7
GROUNDWATER - POSITIVE DETECTION SUMMARY
SITE 86, ABOVEGROUND STORAGE TANK AREA
REMEDIAL INVESTIGATION, CTO-0303
MCAS, NEW RIVER, NORTH CAROLINA
TCL ORGANICS

LOCATION	86-GW13-01	86-GW14IW-01	86-GW15DW-01	86-GW15IW-01	86-GW16DW-01	86-GW16IW-01
DATE SAMPLED	03/23/95	03/22/95	03/21/95	03/22/95	03/20/95	03/22/95
VOLATILES (ug/l)						
1,1-DICHLOROETHANE	10 U	10 U	10 U	10 U	10 U	10 U
1,2-DICHLOROETHENE (TOTAL)	10 U	10 U	10 U	73	10 U	10 U
TRICHLOROETHENE	10 U	10 U	10 U	10 U	10 U	10 U
BENZENE	10 U	10 U	10 U	8	10 U	10 U
TETRACHLOROETHENE	10 U	10 U	10 U	10 U	10 U	10 U
SEMIVOLATILES (ug/l)						
NAPHTHALENE	10 U	10 U	10 U	10 U	10 U	10 U
DIBENZOFURAN	10 U	10 U	10 U	10 U	10 U	10 U
FLUORENE	10 U	10 U	10 U	10 U	10 U	10 U
DI-N-BUTYLPHTHALATE	10 U	10 U	10 U	10 U	10 U	10 U

UG/L - microgram per liter
J - value is estimated
NA - not analyzed
U - not detected
UJ - not detected, value is estimated

**TABLE 4-7
GROUNDWATER - POSITIVE DETECTION SUMMARY
SITE 86, ABOVEGROUND STORAGE TANK AREA
REMEDIAL INVESTIGATION, CTO-0303
MCAS, NEW RIVER, NORTH CAROLINA
TCL ORGANICS**

LOCATION	86-GW17DW-01	86-GW17IW-01	86-GW18DW-01	86-GW19DW-01	86-GW20IW-01	86-GW21IW-01
DATE SAMPLED	03/21/95	03/23/95	03/22/95	03/26/95	04/11/95	05/07/95
VOLATILES (ug/l)						
1,1-DICHLOROETHANE	10 U	10 U	10 U	10 U	10 U	10 U
1,2-DICHLOROETHENE (TOTAL)	10 U	10 U	10 U	10 U	24 J	3 J
TRICHLOROETHENE	10 U	10 U	10 U	10 U	190	10 U
BENZENE	10 U	10 U	10 U	10 U	10 U	2 J
TETRACHLOROETHENE	10 U	10 U	10 U	10 U	10 U	10 U
SEMIVOLATILES (ug/l)						
NAPHTHALENE	10 U	10 U	10 U	10 U	10 U	NA
DIBENZOFURAN	10 U	10 U	10 U	10 U	10 U	NA
FLUORENE	10 U	10 U	10 U	10 U	10 U	NA
DI-N-BUTYLPHTHALATE	10 U	23	10 U	10 U	10 U	NA

UG/L - microgram per liter
J - value is estimated
NA - not analyzed
U - not detected
UJ - not detected, value is estimated

TABLE 4-7
GROUNDWATER - POSITIVE DETECTION SUMMARY
SITE 86, ABOVEGROUND STORAGE TANK AREA
REMEDIAL INVESTIGATION, CTO-0303
MCAS, NEW RIVER, NORTH CAROLINA
TCL ORGANICS

LOCATION	86-GW22IW-01	86-GW23IW-01
DATE SAMPLED	05/07/95	05/07/95
VOLATILES (ug/l)		
1,1-DICHLOROETHANE	10 U	10 U
1,2-DICHLOROETHENE (TOTAL)	10 UJ	10 UJ
TRICHLOROETHENE	10 U	10 U
BENZENE	10 U	10 U
TETRACHLOROETHENE	10 U	10 U
SEMIVOLATILES (ug/l)		
NAPHTHALENE	NA	NA
DIBENZOFURAN	NA	NA
FLUORENE	NA	NA
DI-N-BUTYLPHTHALATE	NA	NA

UG/L - microgram per liter
J - value is estimated
NA - not analyzed
U - not detected
UJ - not detected, value is estimated

TABLE 4-8
GROUNDWATER - POSITIVE DETECTION SUMMARY
SITE 86, ABOVEGROUND STORAGE TANK AREA
REMEDIAL INVESTIGATION, CTO-0303
MCAS, NEW RIVER, NORTH CAROLINA
TAL METALS

LOCATION DATE SAMPLED	86-GW01-01 03/25/95	86-GW02IW-01 03/25/95	86-GW03-01 03/23/95	86-GW04IW-01 03/23/95	86-GW05-01 03/24/95	86-GW06IW-01 03/24/95
ANALYTES (ug/l)						
ALUMINUM, TOTAL	101 U	106 U	815	31.6 U	41.3 U	96.5 U
ANTIMONY, TOTAL	20.7 U	20.7 U	20.7 U	20.7 U	20.7 U	20.7 U
ARSENIC, TOTAL	38.8	1.9 U	1.9 U	1.9 UJ	33	1.9 UJ
BARIUM, TOTAL	14.6 U	10.4 U	35.4	5.2 U	16.3 U	5.8 U
CALCIUM, TOTAL	937	80400	8250	80100	1270	25600
IRON, TOTAL	42300	8070	281	5860	30400	4130
LEAD, TOTAL	1 U	1 U	1 U	1 U	1 U	28.3
MAGNESIUM, TOTAL	1080	2360	1580	3270	2600	1860
MANGANESE, TOTAL	3.8	74	14	82.7	6.2	57.5
POTASSIUM, TOTAL	685 U	2650	927	2540	717	2360
SELENIUM, TOTAL	1.5 U	1.5 U	1.5 U	1.5 U	1.5 U	1.5 U
SODIUM, TOTAL	36800	10600	10400	12100	28900	8730
VANADIUM, TOTAL	2.3 U	2.3 U	2.3 U	2.3 U	2.3 U	2.3 U
ZINC, TOTAL	3.8 U	3.8 U	3.8 U	3.8 U	3.8 U	3.8 U

UG/L - microgram per liter
J - value is estimated
U - not detected
UJ - not detected, value is estimated

TABLE 4-8
GROUNDWATER - POSITIVE DETECTION SUMMARY
SITE 86, ABOVEGROUND STORAGE TANK AREA
REMEDIAL INVESTIGATION, CTO-0303
MCAS, NEW RIVER, NORTH CAROLINA
TAL METALS

LOCATION DATE SAMPLED	86-GW07-01 03/25/95	86-GW08IW-01 03/24/95	86-GW09-01 03/23/95	86-GW10IW-01 03/24/95	86-GW11-01 03/23/95	86-GW12IW-01 03/23/95
ANALYTES (ug/l)						
ALUMINUM, TOTAL	24 U	37.1 U	187	166 U	129 U	85.9 U
ANTIMONY, TOTAL	20.7 U	20.7 U	20.7 U	20.7 U	20.7 U	20.7 U
ARSENIC, TOTAL	17	1.9 U	1.9 U	1.9 UJ	1.3 U	1.9 U
BARIUM, TOTAL	20.6 U	34.7	44.5	4.2 U	27	24.6
CALCIUM, TOTAL	10400	145000	5340	26300	72700	20100
IRON, TOTAL	68300	12000	257	9270	12300	8810
LEAD, TOTAL	1 U	1 U	1 U	1 U	1.6 U	1 U
MAGNESIUM, TOTAL	3390	3130	762	6570	17300	3780
MANGANESE, TOTAL	6.8	74.6	7.9	114	282	72.5
POTASSIUM, TOTAL	769	2620	989	2310	19100	3080
SELENIUM, TOTAL	1.5 U	1.5 U	1.5 U	1.5 U	1.5 U	1.5 U
SODIUM, TOTAL	16000	14200	7420	31400	19700	28500
VANADIUM, TOTAL	2.3 U	2.3 U	2.3 U	2.3 U	100	2.3 U
ZINC, TOTAL	3.8 U	3.8 U	3.8 U	3.8 U	3.8 U	32.1

UG/L - microgram per liter
J - value is estimated
U - not detected
UJ - not detected, value is estimated

TABLE 4-8
GROUNDWATER - POSITIVE DETECTION SUMMARY
SITE 86, ABOVEGROUND STORAGE TANK AREA
REMEDIAL INVESTIGATION, CTO-0303
MCAS, NEW RIVER, NORTH CAROLINA
TAL METALS

LOCATION DATE SAMPLED	86-GW13-01 03/23/95	86-GW14IW-01 03/22/95	86-GW15DW-01 03/21/95	86-GW15IW-01 03/22/95	86-GW16DW-01 03/20/95	86-GW16IW-01 03/22/95
ANALYTES (ug/l)						
ALUMINUM, TOTAL	197 U	26.1 U	136 U	32.6 U	148 U	29.9 U
ANTIMONY, TOTAL	20.7 U	20.7 U	20.7 U	20.7 U	23.6 U	20.7 U
ARSENIC, TOTAL	1.3 U	1.3 U	5.7	1.3 U	3.7	1.3 U
BARIUM, TOTAL	43.2	14.1 U	9.3 U	15.5 U	9.7 U	17 U
CALCIUM, TOTAL	28200	106000	47900	70300	51800	91900
IRON, TOTAL	1310	6940	78 U	1020	165	773
LEAD, TOTAL	1.6 U	1.6 U	1.6 U	1.6 U	1.6 U	1.6 U
MAGNESIUM, TOTAL	2770	1900	3220	2180	2980	3930
MANGANESE, TOTAL	25.4	55.1	9.7 U	107	18	352
POTASSIUM, TOTAL	2360	2150	6510	1680	7150	2600
SELENIUM, TOTAL	1.5 U	1.5 U	1.5 U	1.5 U	1.6	1.5 U
SODIUM, TOTAL	5340	6640	27900	7100	53000	33900
VANADIUM, TOTAL	2.3 U	2.4 U	6.8 U	2.3 U	11.7 U	3.9 U
ZINC, TOTAL	3.8 U	3.8 U	11.5 J	38.7 J	20.7 J	15.1 J

UG/L - microgram per liter
J - value is estimated
U - not detected
UJ - not detected, value is estimated

TABLE 4-8
GROUNDWATER - POSITIVE DETECTION SUMMARY
SITE 86, ABOVEGROUND STORAGE TANK AREA
REMEDIAL INVESTIGATION, CTO-0303
MCAS, NEW RIVER, NORTH CAROLINA
TAL METALS

LOCATION DATE SAMPLED	86-GW17DW-01 03/21/95	86-GW17IW-01 03/23/95	86-GW18DW-01 03/22/95	86-GW19DW-01 03/26/95	86-GW20IW-01 04/11/95	86-GW21IW-01 05/07/95
ANALYTES (ug/l)						
ALUMINUM, TOTAL	30.6 U	197 U	87.1 U	16.8 U	15.7 U	21.2 U
ANTIMONY, TOTAL	20.7 U	20.7 U	20.7 U	10.9 U	12 U	20.8 U
ARSENIC, TOTAL	1.3 U	1.3 U	3	2.5	1.7 U	1.7 U
BARIUM, TOTAL	12.3 U	38.1	3.4 U	8.6	18.8	23.9
CALCIUM, TOTAL	32700	112000	34100	41800	75700	75600
IRON, TOTAL	47.3 U	2520	78.6 U	5.1	1300	884
LEAD, TOTAL	1.6 U	1.6 U	1.6 U	1.6 U	0.8 U	0.8 UJ
MAGNESIUM, TOTAL	6130	3930	5440	4130	2760	3310
MANGANESE, TOTAL	3.9 U	416	8.4 U	4.3 U	101	131
POTASSIUM, TOTAL	15400	1800	12700	8230	1950	2610 J
SELENIUM, TOTAL	1.5 U	1.5 U	1.5 U	1.5 U	1.8 U	1.8 U
SODIUM, TOTAL	98200	15000	90200	49900	10900	25500
VANADIUM, TOTAL	2.4 U	2.7 U	4 U	2.8 U	1.5 U	2 U
ZINC, TOTAL	12.1 J	3.9 J	12.2 J	1.9 U	5.2 U	6 U

UG/L - microgram per liter
 J - value is estimated
 U - not detected
 UJ - not detected, value is estimated

TABLE 4-8
GROUNDWATER - POSITIVE DETECTION SUMMARY
SITE 86, ABOVEGROUND STORAGE TANK AREA
REMEDIAL INVESTIGATION, CTO-0303
MCAS, NEW RIVER, NORTH CAROLINA
TAL METALS

LOCATION DATE SAMPLED	86-GW22IW-01 05/07/95	86-GW23IW-01 05/07/95
ANALYTES (ug/l)		
ALUMINUM, TOTAL	21.2 U	21.2 U
ANTIMONY, TOTAL	20.8 U	20.8 U
ARSENIC, TOTAL	1.7 U	1.7 U
BARIUM, TOTAL	11.4	12.7
CALCIUM, TOTAL	58200	55300
IRON, TOTAL	511	577
LEAD, TOTAL	0.8 UJ	0.8 UJ
MAGNESIUM, TOTAL	2440	2960
MANGANESE, TOTAL	82.6	88.4
POTASSIUM, TOTAL	2350 J	2070 J
SELENIUM, TOTAL	2 J	1.8 J
SODIUM, TOTAL	11800	25900
VANADIUM, TOTAL	2 U	2 U
ZINC, TOTAL	6 U	6 U

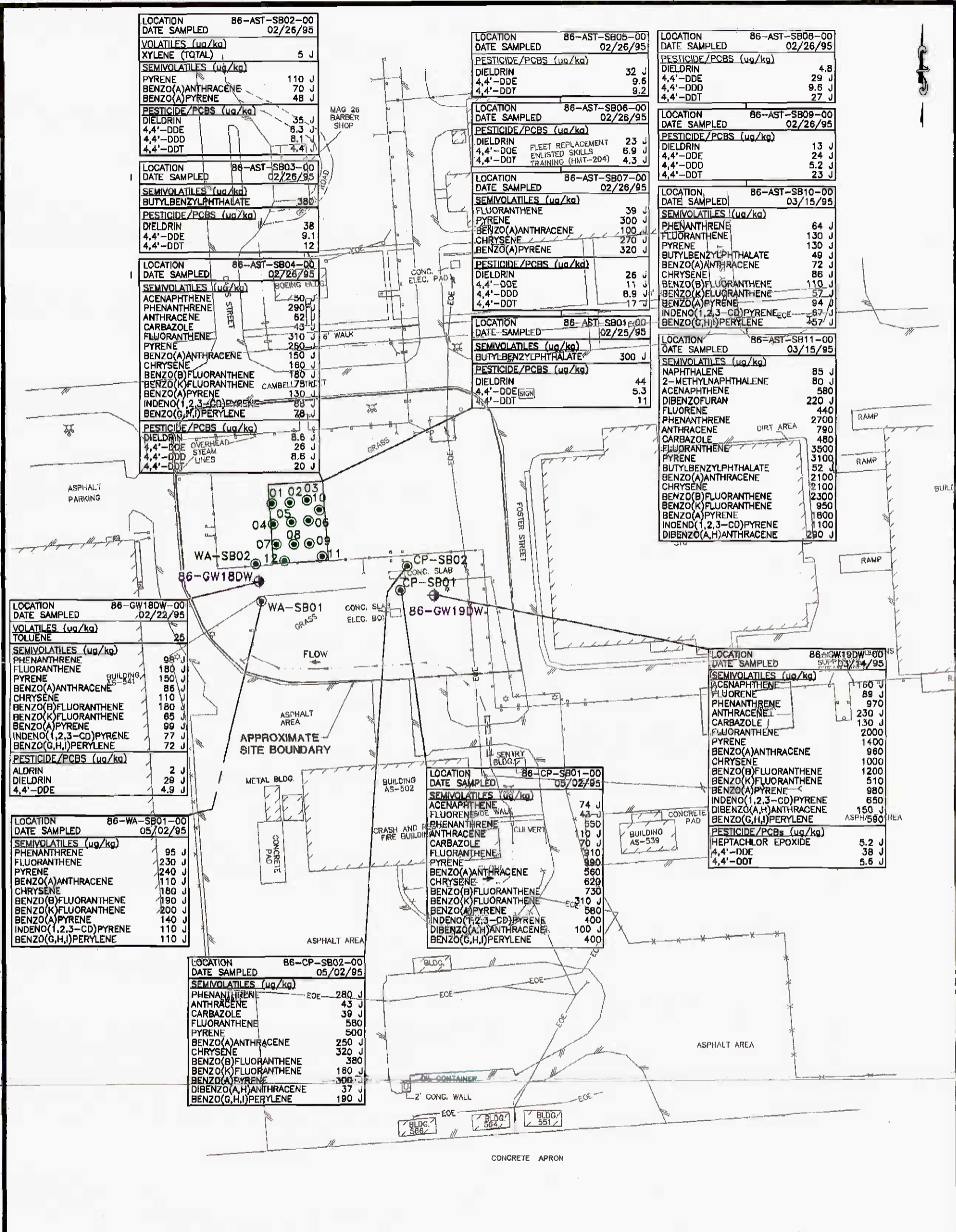
UG/L - microgram per liter
J - value is estimated
U - not detected
UJ - not detected, value is estimated

TABLE 4-9
GROUNDWATER - POSITIVE DETECTION SUMMARY
SITE 86, ABOVEGROUND STORAGE TANK AREA
REMEDIAL INVESTIGATION, CTO-0303
MCAS, NEW RIVER, NORTH CAROLINA
DISSOLVED METALS

LOCATION DATE SAMPLED	86-GW01D-01 03/25/95	86-GW02IWD-01 03/25/95	86-GW15DWD-01 03/21/95	86-GW15IWD-01 03/22/95	86-GW21IWD-01 05/07/95
ANALYTES (ug/l)					
ARSENIC, SOLUBLE	39.1	1.9 U	4.7	1.3 U	1.7 U
BARIUM, SOLUBLE	13 U	8.7 U	9.2 U	16.5 U	24
CALCIUM, SOLUBLE	928	82000	47200	70300	75100
IRON, SOLUBLE	41000	8140	54.7 U	995	851
LEAD, SOLUBLE	1 U	1 U	1.6 U	1.6 U	0.82 J
MAGNESIUM, SOLUBLE	1070	2430	3250	2190	3280
MANGANESE, SOLUBLE	4.2	76.6	10.2	106	130
POTASSIUM, SOLUBLE	685 U	2110	7280	2070	2310 J
SODIUM, SOLUBLE	36000	10800	28400	7080	25200
ZINC, SOLUBLE	5 U	3.8 U	15.6 J	19.8 J	6 U

UG/L - microgram per liter
J - value is estimated
U - not detected

SECTION 4.0 FIGURES



LOCATION	86-AST-SB02-00
DATE SAMPLED	02/26/95
VOLATILES (ug/kg)	
XYLENE (TOTAL)	5 J
SEMIVOLATILES (ug/kg)	
PYRENE	110 J
BENZO(A)ANTHRACENE	70 J
BENZO(A)PYRENE	48 J
PESTICIDE/PCBS (ug/kg)	
DIELDRIN	35 J
4,4'-DDE	6.3 J
4,4'-DDD	8.1 J
4,4'-DDT	7.4 J

LOCATION	86-AST-SB05-00
DATE SAMPLED	02/26/95
PESTICIDE/PCBS (ug/kg)	
DIELDRIN	32 J
4,4'-DDE	9.6 J
4,4'-DDT	9.2 J

LOCATION	86-AST-SB08-00
DATE SAMPLED	02/26/95
PESTICIDE/PCBS (ug/kg)	
DIELDRIN	4.8 J
4,4'-DDE	29 J
4,4'-DDD	9.6 J
4,4'-DDT	27 J

LOCATION	86-AST-SB03-00
DATE SAMPLED	02/26/95
SEMIVOLATILES (ug/kg)	
BUTYLBENZYLPHTHALATE	380 J
PESTICIDE/PCBS (ug/kg)	
DIELDRIN	38 J
4,4'-DDE	9.1 J
4,4'-DDT	12 J

LOCATION	86-AST-SB06-00
DATE SAMPLED	02/26/95
PESTICIDE/PCBS (ug/kg)	
DIELDRIN	23 J
4,4'-DDE	6.9 J
4,4'-DDT	4.3 J

LOCATION	86-AST-SB09-00
DATE SAMPLED	02/26/95
PESTICIDE/PCBS (ug/kg)	
DIELDRIN	13 J
4,4'-DDE	24 J
4,4'-DDD	5.2 J
4,4'-DDT	23 J

LOCATION	86-AST-SB04-00
DATE SAMPLED	02/26/95
SEMIVOLATILES (ug/kg)	
ACENAPHTHENE	50 J
PHENANTHRENE	290 J
ANTHRACENE	62 J
CARBAZOLE	43 J
FLUORANTHENE	310 J
PYRENE	260 J
BENZO(A)ANTHRACENE	150 J
CHRYSENE	160 J
BENZO(B)FLUORANTHENE	180 J
BENZO(K)FLUORANTHENE	130 J
BENZO(A)PYRENE	130 J
INDENO(1,2,3-CD)PYRENE	88 J
BENZO(G,H,I)PERYLENE	78 J
PESTICIDE/PCBS (ug/kg)	
DIELDRIN	8.6 J
4,4'-DDE	26 J
4,4'-DDD	8.6 J
4,4'-DDT	20 J

LOCATION	86-AST-SB07-00
DATE SAMPLED	02/26/95
SEMIVOLATILES (ug/kg)	
FLUORANTHENE	39 J
PYRENE	300 J
BENZO(A)ANTHRACENE	100 J
CHRYSENE	270 J
BENZO(A)PYRENE	320 J
PESTICIDE/PCBS (ug/kg)	
DIELDRIN	26 J
4,4'-DDE	11 J
4,4'-DDD	8.9 J
4,4'-DDT	17 J

LOCATION	86-AST-SB10-00
DATE SAMPLED	03/15/95
SEMIVOLATILES (ug/kg)	
PHENANTHRENE	64 J
FLUORANTHENE	130 J
PYRENE	130 J
BUTYLBENZYLPHTHALATE	49 J
BENZO(A)ANTHRACENE	72 J
CHRYSENE	86 J
BENZO(B)FLUORANTHENE	110 J
BENZO(K)FLUORANTHENE	57 J
BENZO(A)PYRENE	94 J
INDENO(1,2,3-CD)PYRENE	87 J
BENZO(G,H,I)PERYLENE	45 J

LOCATION	86-AST-SB01-00
DATE SAMPLED	02/25/95
SEMIVOLATILES (ug/kg)	
BUTYLBENZYLPHTHALATE	300 J
PESTICIDE/PCBS (ug/kg)	
DIELDRIN	44 J
4,4'-DDE	5.3 J
4,4'-DDT	11 J

LOCATION	86-AST-SB11-00
DATE SAMPLED	03/15/95
SEMIVOLATILES (ug/kg)	
NAPHTHALENE	85 J
2-METHYLNAPHTHALENE	80 J
ACENAPHTHENE	580 J
DIBENZOFURAN	220 J
FLUORENE	440 J
PHENANTHRENE	2700 J
ANTHRACENE	790 J
CARBAZOLE	480 J
FLUORANTHENE	3500 J
PYRENE	3100 J
BUTYLBENZYLPHTHALATE	52 J
BENZO(A)ANTHRACENE	2100 J
CHRYSENE	2100 J
BENZO(B)FLUORANTHENE	2300 J
BENZO(K)FLUORANTHENE	950 J
BENZO(A)PYRENE	1800 J
INDENO(1,2,3-CD)PYRENE	1100 J
DIBENZO(A,H)ANTHRACENE	290 J

LOCATION	86-GW18DW-00
DATE SAMPLED	02/22/95
VOLATILES (ug/kg)	
TOLUENE	25 J
SEMIVOLATILES (ug/kg)	
PHENANTHRENE	98 J
FLUORANTHENE	180 J
PYRENE	150 J
BENZO(A)ANTHRACENE	86 J
CHRYSENE	110 J
BENZO(B)FLUORANTHENE	180 J
BENZO(K)FLUORANTHENE	65 J
BENZO(A)PYRENE	99 J
INDENO(1,2,3-CD)PYRENE	77 J
BENZO(G,H,I)PERYLENE	72 J
PESTICIDE/PCBS (ug/kg)	
ALDRIN	2 J
DIELDRIN	29 J
4,4'-DDE	4.9 J

LOCATION	86-WA-SB01-00
DATE SAMPLED	05/02/95
SEMIVOLATILES (ug/kg)	
PHENANTHRENE	95 J
FLUORANTHENE	230 J
PYRENE	240 J
BENZO(A)ANTHRACENE	110 J
CHRYSENE	180 J
BENZO(B)FLUORANTHENE	190 J
BENZO(K)FLUORANTHENE	200 J
BENZO(A)PYRENE	140 J
INDENO(1,2,3-CD)PYRENE	110 J
BENZO(G,H,I)PERYLENE	110 J

LOCATION	86-CP-SB02-00
DATE SAMPLED	05/02/95
SEMIVOLATILES (ug/kg)	
PHENANTHRENE	280 J
ANTHRACENE	43 J
CARBAZOLE	39 J
FLUORANTHENE	580 J
PYRENE	500 J
BENZO(A)ANTHRACENE	250 J
CHRYSENE	320 J
BENZO(B)FLUORANTHENE	380 J
BENZO(K)FLUORANTHENE	180 J
BENZO(A)PYRENE	300 J
DIBENZO(A,H)ANTHRACENE	37 J
BENZO(G,H,I)PERYLENE	190 J

LOCATION	86-CP-SB01-00
DATE SAMPLED	05/02/95
SEMIVOLATILES (ug/kg)	
ACENAPHTHENE	74 J
FLUORENE	43 J
PHENANTHRENE	550 J
ANTHRACENE	10 J
CARBAZOLE	70 J
FLUORANTHENE	910 J
PYRENE	990 J
BENZO(A)ANTHRACENE	560 J
CHRYSENE	620 J
BENZO(B)FLUORANTHENE	730 J
BENZO(K)FLUORANTHENE	310 J
BENZO(A)PYRENE	580 J
INDENO(1,2,3-CD)PYRENE	400 J
DIBENZO(A,H)ANTHRACENE	100 J
BENZO(G,H,I)PERYLENE	400 J

LOCATION	86-GW19DW-00
DATE SAMPLED	03/03/95
SEMIVOLATILES (ug/kg)	
ACENAPHTHENE	160 J
FLUORENE	89 J
PHENANTHRENE	970 J
ANTHRACENE	230 J
CARBAZOLE	130 J
FLUORANTHENE	2000 J
PYRENE	1400 J
BENZO(A)ANTHRACENE	960 J
CHRYSENE	1000 J
BENZO(B)FLUORANTHENE	1200 J
BENZO(K)FLUORANTHENE	510 J
BENZO(A)PYRENE	980 J
INDENO(1,2,3-CD)PYRENE	650 J
DIBENZO(A,H)ANTHRACENE	150 J
BENZO(G,H,I)PERYLENE	590 J
PESTICIDE/PCBS (ug/kg)	
HEPTACHLOR EPOXIDE	5.2 J
4,4'-DDE	38 J
4,4'-DDT	5.6 J

303067R1

LEGEND

- 86-GW18DW PILOT TEST BORING FOR DEEP MONITORING WELL
- SB09 SOIL BORING LOCATION
- FLOW DIRECTION OF SURFACE WATER FLOW
- EOE OVERHEAD ELECTRIC LINE & UTILITY POLE
- ASPHALT ROAD
- CENTERLINE OF DRAINAGE SWALE
- LIGHTPOLE
- STRUCTURE
- GRAVEL ROAD
- FENCE
- GUY WIRE
- FIRE HYDRANT

SOURCE: LANTDIV, OCT, 1991

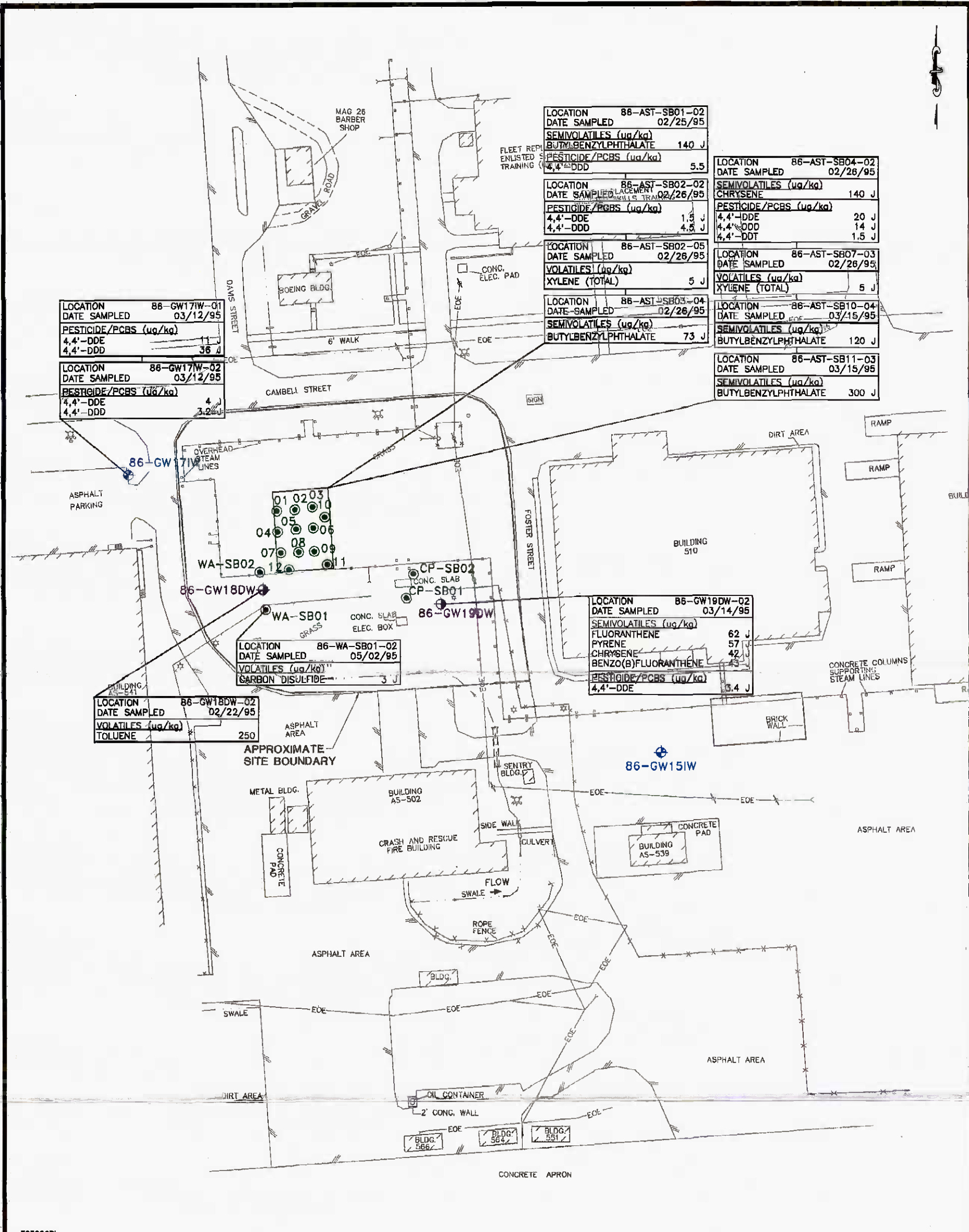
NOTE: LOCATIONS SHOWN WITHOUT CONCENTRATIONS INDICATE NONDETECTABLE LEVELS.

80 0 40 80
1 inch = 80 ft.

Baker
Baker Environmental, Inc.

FIGURE 4-1
ORGANIC COMPOUNDS IN SURFACE SOIL
SITE 86, ABOVE GROUND STORAGE TANK AREA
REMEDIATION INVESTIGATION, CTO-0303
MARINE CORPS AIR STATION, NEW RIVER
NORTH CAROLINA

01719WB5V



303088RI

LEGEND

- 86-GW041W PILOT TEST BORING FOR INTERMEDIATE MONITORING WELL
- 86-GW18DW PILOT TEST BORING FOR DEEP MONITORING WELL
- SB09 SOIL BORING LOCATION
- FLOW DIRECTION OF SURFACE WATER FLOW
- EOE OVERHEAD ELECTRIC LINE & UTILITY POLE
- ASPHALT ROAD
- CENTERLINE OF DRAINAGE SWALE
- LIGHTPOLE
- STRUCTURE
- GRAVEL ROAD
- FENCE
- GUY WIRE
- FIRE HYDRANT

SOURCE: LANTRIV, OCT. 1991

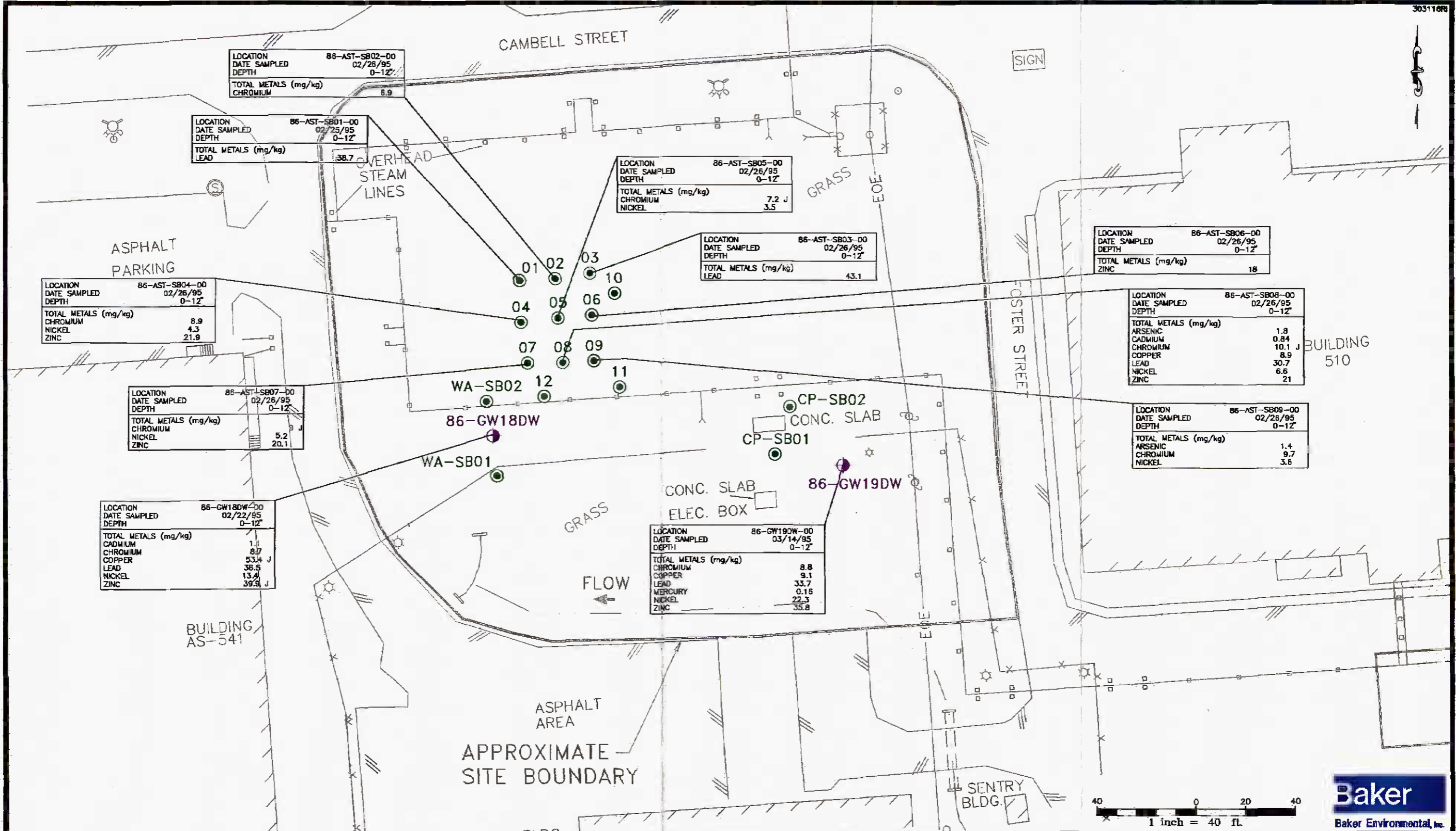
NOTE: LOCATIONS SHOWN WITHOUT CONCENTRATIONS INDICATE NONDETECTABLE LEVELS.

1 inch = 80 ft.

Baker
Baker Environmental, Inc.

FIGURE 4-2
ORGANIC COMPOUNDS IN SUBSURFACE SOIL
SITE 86, ABOVE GROUND STORAGE TANK AREA
REMEDIAL INVESTIGATION, CTO-0303

MARINE CORPS AIR STATION, NEW RIVER
NORTH CAROLINA

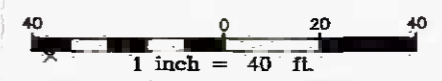


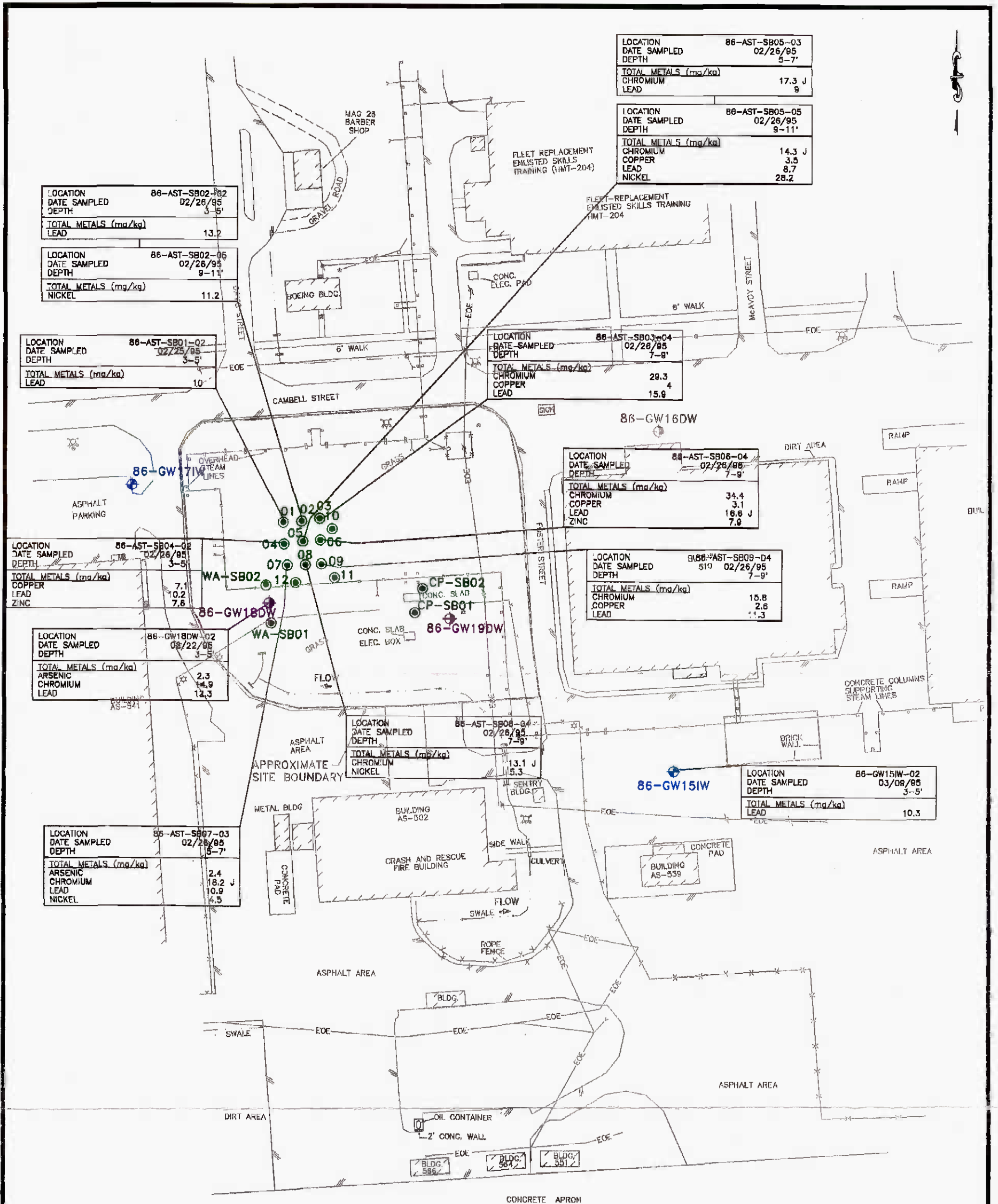
LEGEND

86-GW15DW PILOT TEST BORING FOR DEEP MONITORING WELL

CP-SB01 SOIL BORING LOCATION

FIGURE 4-3
 SELECTED TAL METALS IN SURFACE SOIL
 SITE 86, ABOVE GROUND STORAGE TANK AREA
 REMEDIAL INVESTIGATION, CTO-0303
 MARINE CORPS AIR STATION, NEW RIVER
 NORTH CAROLINA





303115R

LEGEND

- 86-GW15IW PILOT TEST BORING FOR INTERMEDIATE MONITORING WELL
- 86-GW18DW PILOT TEST BORING FOR DEEP MONITORING WELL
- SB09 SOIL BORING LOCATION
- FLOW DIRECTION OF SURFACE WATER FLOW
- EOE OVERHEAD ELECTRIC LINE & UTILITY POLE
- ASPHALT ROAD
- CENTERLINE OF DRAINAGE SWALE
- LIGHTPOLE
- STRUCTURE
- GRAVEL ROAD
- FENCE
- GUY WIRE
- FIRE HYDRANT

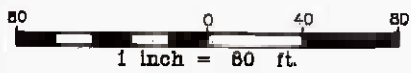
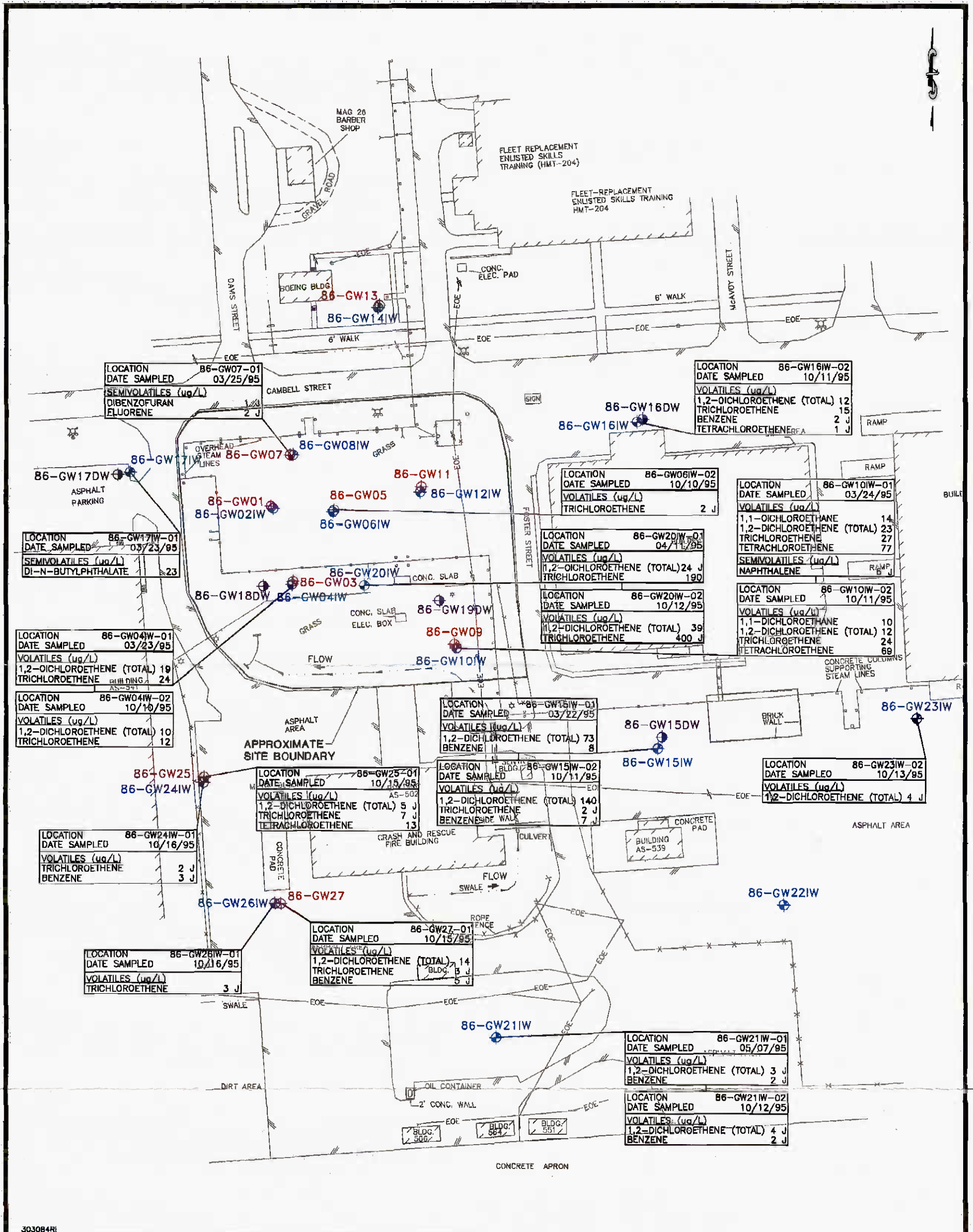


FIGURE 4-4
SELECTED TAL METALS IN
SUBSURFACE SOIL
SITE 86, ABOVE GROUND STORAGE TANK AREA
REMEDIAL INVESTIGATION, CTO-0303
MARINE CORPS AIR STATION, NEW RIVER
NORTH CAROLINA

SOURCE: LANTDIV, OCT. 1991



303084R

LEGEND

- 86-GW01 SHALLOW MONITORING WELL
- 86-GW04IW INTERMEDIATE MONITORING WELL
- 86-GW18DW DEEP MONITORING WELL
- FLOW DIRECTION OF SURFACE WATER FLOW
- EOE OVERHEAD ELECTRIC LINE & UTILITY POLE
- ASPHALT ROAD
- CENTERLINE OF DRAINAGE SWALE
- LIGHTPOLE
- STRUCTURE
- GRAVEL ROAD
- FENCE
- GUY WIRE
- FIRE HYDRANT

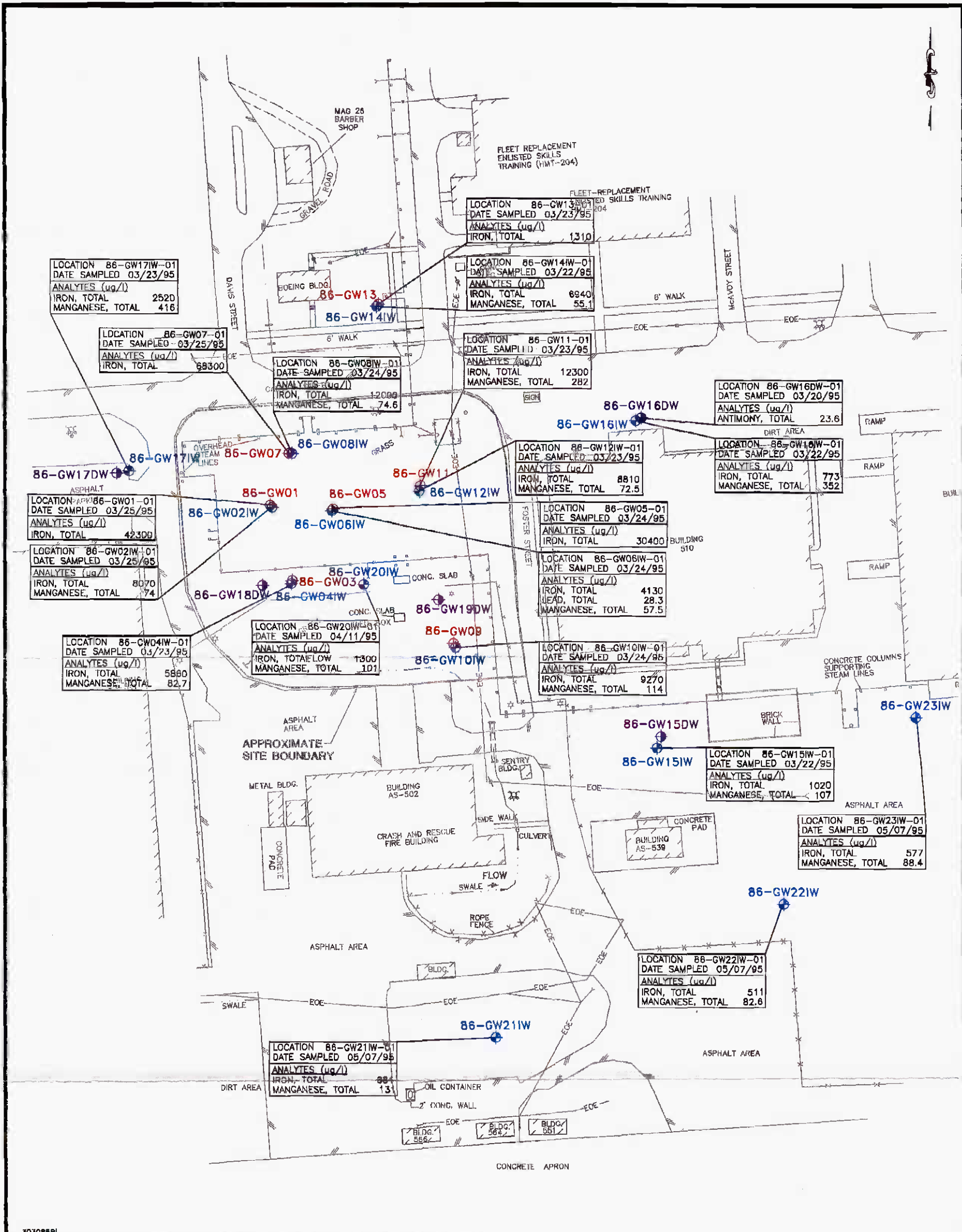
SOURCE: LANTDIV, OCT. 1991

NOTE: LOCATIONS SHOWN WITHOUT CONCENTRATIONS INDICATE NONDETECTABLE LEVELS.

1 inch = 80 ft.

Baker
Baker Environmental, Inc.

FIGURE 4-5
ORGANIC COMPOUNDS IN GROUNDWATER
SITE 86, ABOVE GROUND STORAGE TANK AREA
REMEDIAL INVESTIGATION, CTO-0303
MARINE CORPS AIR STATION, NEW RIVER
NORTH CAROLINA



303088R1

LEGEND

- 86-GW01 SHALLOW MONITORING WELL
- 86-GW04IW INTERMEDIATE MONITORING WELL
- 86-GW18DW DEEP MONITORING WELL
- FLOW DIRECTION OF SURFACE WATER FLOW
- EOE OVERHEAD ELECTRIC LINE & UTILITY POLE
- ASPHALT ROAD
- CENTERLINE OF DRAINAGE SWALE
- LIGHTPOLE
- STRUCTURE
- GRAVEL ROAD
- FENCE
- GUY WIRE
- FIRE HYDRANT

SOURCE: LANTDIV, OCT. 1991

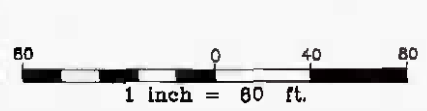


FIGURE 4-6
TOTAL METALS IN GROUNDWATER
ABOVE SCREENING STANDARDS
SITE 86, ABOVE GROUND STORAGE TANK AREA
REMEDIAL INVESTIGATION, CTO-0303
MARINE CORPS AIR STATION, NEW RIVER
NORTH CAROLINA

5.0 CONTAMINANT FATE AND TRANSPORT

The potential for a contaminant to migrate and persist in an environmental medium is critical when evaluating the potential for a chemical to elicit an adverse human health or ecological effect. The environmental mobility of a chemical is influenced by its physical and chemical properties, the physical characteristics of the site, and the site chemistry. This section presents a discussion of the various physical and chemical properties of significant contaminants in Site 86 media discussed in Section 4.0 and their fate and transport in the environment.

5.1 Chemical and Physical Properties Impacting Fate and Transport

Table 5-1 presents the physical and chemical properties associated with the organic compounds detected during this investigation. These properties determine the inherent environmental mobility and fate of a contaminant. The properties of interest include:

- Vapor pressure
- Water solubility
- Octanol/water partition coefficient
- Organic carbon adsorption coefficient (sediment partition)
- Specific gravity
- Henry's Law constant

A discussion of the environmental significance of each of these properties follows.

Vapor pressure provides an indication of the rate at which a chemical may volatilize. It is of primary significance at environmental interfaces such as surface soil/air and surface water/air. Volatilization can be important when evaluating groundwater and subsurface soils, particularly when selecting remedial technologies. Vapor pressure for monocyclic aromatics is generally higher than vapor pressures for PAHs. Contaminants with higher vapor pressures (e.g., VOCs) will enter the atmosphere at a quicker rate than the contaminants with low vapor pressures (e.g., PCBs).

The rate at which a contaminant is leached from soil by infiltrating precipitation is proportional to its water solubility. More soluble contaminants are usually more readily leached than less soluble contaminants. The water solubilities indicate that the volatile organic contaminants, including monocyclic aromatics, are usually several orders-of-magnitude more soluble than PAHs. Consequently, highly soluble compounds such as the chlorinated VOCs will go into solution faster and possibly in greater concentrations than less soluble compounds. The solubility of a specific compound is dependent on the chemistry of the groundwater and aquifer material. Factors such as groundwater pH, Eh (redox potential), temperature, and the presence of other compounds can greatly affect the solubility.

The octanol/water partition coefficient (K_{ow}) is the ratio of the chemical concentration in octanol divided by the concentration in water. The octanol/water partition coefficient has been shown to correlate well with bioconcentration factors in aquatic organisms and adsorption to soil or sediment. Specifically, a linear relationship between octanol/water partition coefficients and the uptake of chemicals by fatty tissues of animal and human receptors (the bioconcentration factor - BCF) has been established (Lyman et al., 1982). The coefficient is also useful in characterizing the sorption of compounds by organic soils where experimental values are not available.

The organic carbon adsorption coefficient (K_{oc}) indicates the tendency of a chemical to adhere to the organic carbon in soil particles. The solubility of a chemical in water is inversely proportional to the K_{oc} . Contaminants with high soil/sediment adsorption coefficients generally have low water solubilities. For example, contaminants such as PAHs are relatively immobile in the environment, are preferentially bound to the soil, and therefore have a higher K_{oc} value. These compounds are not subject to aqueous transport to the extent of compounds with higher water solubilities. Mechanical activities (e.g., erosion) and the physical characteristics of surface soils may, however, increase the mobility of these bound soil contaminants.

Specific gravity is the ratio of a given volume of pure chemical at a specified temperature to the weight of the same volume of water at a given temperature. Its primary use is to determine whether a contaminant will have a tendency to "float" or "sink" (as an immiscible liquid) in water if it exceeds its corresponding water solubility.

Vapor pressure and water solubility are of use in determining volatilization rates from surface water bodies and from groundwater. These two parameters can be used to estimate an equilibrium concentration of a contaminant in the water phase and in the air directly above the water. This relationship is expressed as Henry's Law Constant.

A quantitative assessment of mobility has been developed that uses water solubility (S), vapor pressure (VP), and organic carbon partition coefficient (K_{oc}) (Laskowski, 1983). This value is referred to as the Mobility Index (MI). It is defined as:

$$MI = \log((S*VP)/K_{oc})$$

A scale to evaluate MI as presented by Ford and Gurba (1984) is:

<u>Relative MI</u>	<u>Mobility Description</u>
> 5	extremely mobile
0 to 5	very mobile
-5 to 0	slightly mobile
-10 to -5	immobile
< -10	very immobile

The mobility index of each organic analyte detected at Site 86 is presented on Table 5-1.

5.2 Contaminant Transport Pathways

Based on the evaluation of existing conditions at Site 86, the following potential contaminant transport pathways have been identified:

- Leaching of soil contaminants to groundwater
- Migration of groundwater contaminants, laterally and vertically

Contaminant concentrations may be affected by one or more mechanisms during transport. Contaminants may be physically transformed by volatilization or precipitation. Contaminants may be chemically transformed through photolysis, hydrolysis, or oxidation/reduction. Contaminants may be biologically transformed by biodegradation. Additionally, contaminants may accumulate in one or more

media. Since different transformation mechanisms are important for different contaminants, these mechanisms are discussed as necessary in Section 5.3.

The paragraphs which follow describe the potential transport pathways listed above with respect to significant compound concentrations. Significant compound concentrations refers to those compounds discussed in Section 4.0 frequently occurring above criteria comparisons. Specific fate and transport concerns are discussed in Section 5.3.

5.2.1 Leaching of Soil Contaminants to Groundwater

Pesticides and PAHs were detected in surface and/or subsurface soil samples at scattered locations at Site 86 (Figures 4-1 and 4-2). VOCs were detected in two surface and subsurface soil samples. Chlorinated VOCs, iron and manganese, were detected frequently in groundwater samples (Figures 4-3 and 4-4). The detection of SVOCs and other metals in groundwater was limited.

Contaminants that adhere to soil particles or have accumulated in soil pore spaces can leach and migrate vertically to the groundwater as a result of infiltration of precipitation. The rate and extent of this leaching is influenced by the depth to the water table, amount of precipitation, rate of infiltration, the physical and chemical properties of the soil, and contaminant.

5.2.2 Migration of Groundwater Contaminants

Organic and inorganic contaminants leaching from soil to groundwater can migrate as dissolved constituents in groundwater in the direction of groundwater flow. Three general processes govern the migration of dissolved contaminants caused by groundwater flow: advection, dispersion, and retardation. Advection is a process by which solutes are carried by groundwater movement. Dispersion is a by mixing of contaminated and uncontaminated water during advection. Retardation is a slowing of contaminant migration caused by the reaction of the solute with the aquifer soil.

Advection is the process by which moving groundwater carries dissolved solutes (Fetter, 1988). Groundwater flow velocities at Site 86 were determined by using a variation of Darcy's equation (discussed in Section 2.5.4). Groundwater flow velocities in the surficial and Castle Hayne aquifers underlying Site 86 range from 0.002 to 0.13 feet/day, or 0.7 to 47.5 feet/year. The direction of the local groundwater flow regime is to the north (based on shallow wells), and likely discharges to Stick Creek. The direction of the regional groundwater flow regime is to the northeast (based on intermediate and deep wells), and likely discharges to the New River.

The Castle Hayne confining unit is absent under Site 86. Vertical gradients under Site 86 range from 0.001 feet/foot at wells 86-GW03/04 to 0.05 feet/foot at wells 86-GW11/12. The direction of this gradient has been consistently downward. Many of the vertical gradients are one order of magnitude greater than horizontal gradients.

Dispersion results from two basic processes; molecular diffusion and mechanical mixing. The kinetic activity of dissolved solutes results in diffusion of solutes from a zone of high concentration to a zone of lower concentration. Dispersion can occur in three directions, longitudinal (in the direction of flow), transverse (horizontally perpendicular to longitudinal), and vertical. Dispersion is largely scale dependent (i.e., the greater the area over which it is measured, the larger the dispersion value). Furthermore, longitudinal dispersion is often observed to be markedly greater than dispersion in the transverse direction of flow. It is often assumed that transverse dispersion is one-tenth longitudinal dispersion (Nichols,

1993). Lacking detailed site studies to determine dispersion, the parameter can be estimated to be one-tenth of the length of the flow path, in the same lithologies (Fetter, 1988).

Retardation is a process whereby a solute concentration is reduced through a chemical, biological, or radioactive change. Solutes can be categorized in two broad classes: conservative and reactive. Conservative solutes do not react with aquifer soil. Reactive solutes will interact with the soil encountered along the flow path through adsorption, partitioning, ion exchange, and other processes. The retardation factor (R) can be calculated by the following equation (Fetter, 1988):

$$R = 1 + (P_b/n)(K_d)$$

where:

P_b = dry bulk density of the soil
 n = porosity of the soil
 k_d = distribution coefficient for the solute with the soil (K_{oc} of the solute times the TOC content of the soil)

The following is a summary of estimated retardation factors for VOCs and SVOC detected in multiple groundwater samples at Site 86:

<u>Solute</u>	<u>Retardation Factor</u>
1,1-Dichloroethane	1.77
1,2-Dichloroethene	2.39
Benzene	3.14
Trichloroethane	4.25
Tetrachloroethene	10.39
Naphthalene	28.66

Retardation factor calculations are presented in Appendix O. The lower the retardation factor, the faster the migration rate. These factors are estimated because of the lack of site-specific data, including TOC analytical data and porosity. It is common however, to estimate retardation factors. The relative differences are useful for describing plume characteristics.

Transformation of chlorinated VOCs is an important fate process (USDHH&S, 1990). Tetrachloroethane will degrade to trichloroethene. Trichloroethene will in turn, degrade primarily to cis-1,2-dichloroethene), and to a lesser extent, trans-1,2-dichloroethene. cis-1,2-Dichloroethene will degrade to chloroethane and, to a lesser extent, vinyl chloride. 1,2-Dichloroethene (trans) will degrade to vinyl chloride.

Total-1,2-dichloroethene, trichloroethene, and tetrachloroethene have been detected in groundwater samples at Site 86. Both trichloroethene and tetrachloroethene are common solvents. Eighty percent of trichloroethene used in the United States is for metal parts cleaning (USDHH&S, 1991), while 50 percent of Tetrachloroethene is used for dry cleaning (USDHH&S, 1990). 1,2-Dichloroethene (cis & trans) is primarily used as a chemical intermediate in production of chlorinated solvents and compounds (USDHH&S, 1994). It is likely that trichloroethene and Tetrachloroethene were used at Camp Lejeune, rather than 1,2-dichloroethene. The presence of 1,2-dichloroethene in groundwater samples is likely a transformation product rather than a primary contaminant.

Immiscible liquids typically occur as a result of a large quantity spill or leak. Subsurface transport of the immiscible contaminants is governed by a set of factors different from those of dissolved contaminants. A contaminant that is present in water above its solubility concentration will form an immiscible liquid. Based on the specific gravity of the contaminant, it will either float or sink in the water.

Movement of immiscible liquids is controlled by entry conditions and flow conditions (Feenstra, et al., 1995). Entry of an immiscible liquid to a subsurface system is primarily controlled by the capillary phenomena. These phenomena arise from the fact that an interfacial tension is present between two mutually immiscible liquids in small pore space. Once in a subsurface system, the rate and direction of flow depends on the density and viscosity of the fluid, the pressure driving the fluid, the hydraulic conductivity of the formation, and the degree of saturation of the fluid in the formation (Feenstra, et al., 1995). Fluids denser than water will sink, fluids lighter than water will float. The driving pressure is related to the amount of fluid released into the environment. An immiscible liquid will flow faster where the fluid is already present in the formation. Contaminants from the immiscible liquids may then dissolve into groundwater, volatilize from groundwater to ground air, evaporate directly into ground air, or sorb from groundwater to solid surfaces.

Metals are inherent to soil and sediment, and groundwater. For this reason, concentrations of metals must be discussed with respect to background or natural concentrations. Metal solutes behave differently than organic solutes. While the fate and transport of metal solutes generally occur by the same three process described above, the fate of metals is significantly affected by groundwater and aquifer matrix chemistry. The concentration of metals and their movement are dependent on such things as ion exchange capacity, pH, and redox potential. Table 5-2 presents an assessment of relative environmental mobilities of inorganics as a function of Eh and pH. Different metals will behave differently under the same conditions. Metal solutes therefore, need to be examined individually. Section 5.3.4 examines the occurrence of individual metals at Site 86.

5.3 Fate and Transport Summary

The paragraphs which follow discuss transport mechanisms and the fate for the significant contaminants discussed in Section 4.0.

5.3.1 Volatile Organic Compounds

VOCs tend to be mobile in environmental media as indicated by their presence in groundwater and their corresponding MI values/retardation factors. Their environmental mobility is a function of high water solubilities, high vapor pressures, low K_{ow} and K_{oc} values, and high mobility indices. Because VOCs are highly mobile in soil, they will readily leach to underlying groundwater.

VOCs potentially related to the storage of used fuel oil were detected in monitoring wells located mainly south and east of the former AST area. Figure 4-3 shows the distribution of the organics, including VOCs in groundwater. Based on each solute's MI value/retardation factor, each solute is expected to migrate at a different rate. Additionally, over time, transformation of the original solutes is expected.

The source area may be located in the vicinity of well 86-GW10IW and 86-GW20IW. This is based on two points. The first point is the presence of less mobile solutes at this well (tetrachloroethene and naphthalene [an SVOC]) at the highest observed concentrations. Well 86-GW20IW exhibits the highest concentration of total VOCs as compared with other wells at the site. The second point is the high percentage of tetrachloroethene relative to transformation products of trichloroethene and

1,2-dichloroethene at well 86-GW10IW. Additionally, note that the highest levels of VOCs detected during the previous investigation (1992) were also detected in well 86-GW10IW.

The relatively higher vertical groundwater flow gradients may have caused the solutes to migrate downward to the second limestone unit. Chlorinated VOCs have been detected in the intermediate wells screened within the second limestone unit (Section 2.4). The interface between the second limestone unit and the silty fine sand unit below may be preventing migration of solutes to the deep monitoring wells. Chlorinated VOCs have not been detected in the deep monitoring wells screened below the silty fine sand unit. Additionally, hydraulic conductivity values are generally higher in the limestone unit as compared to the silty sand below.

5.3.2 Semivolatile Organic Compounds

PAHs were the predominant subgroup of SVOCs detected at Site 86. PAHs were detected primarily in surface soils, and to a lesser extent, in subsurface soils. Low water solubilities, high K_{ow} and K_{oc} values indicate a strong tendency for PAHs to adsorb to soils, and be immobile. This is supported by the fact that PAHs were detected in only three wells (i.e., 86-GW07, 86-GW08IW, and 86GW10IW) at low concentrations.

5.3.3 Pesticides

Pesticides have been detected primarily in surface and to a lesser extent, in subsurface soils at several locations in Site 86 (Figure 4-1). Table 5-1 shows that pesticides are immobile, mainly due to their affinity for soil surfaces. This is supported by the fact that pesticides have not been detected in groundwater samples.

5.3.4 Metals

According to Section 4.0, the presence of metals in soil and above criteria levels is limited. The dissolution of these metals from soils to groundwater has generally not resulted in concentrations exceeding Federal MCLs or state drinking water standards. Two exceptions are iron and manganese. Both metals are naturally occurring in soils, and have frequently been detected in groundwater samples above comparison criteria. The presence of elevated iron and manganese in groundwater may be related to natural phenomena.

Previous studies by Baker and others indicate that iron and manganese are ubiquitous in all media at MCB Camp Lejeune. These studies show that concentrations of iron and manganese are variable and can occur in sediments, surface water and groundwater at levels exceeding comparison criteria. It is possible that elevated levels of iron and manganese in a particular media may not be associated with contamination, but rather be representative of natural conditions.

In a study of trace elements in a coastal plain estuary (Cross, et. al., 1970), iron, manganese, and zinc were found in sediments, surface water, and worm tissue. The study was conducted over a two year period in a river estuary near Morehead City, North Carolina (approximately 40 miles northeast of Camp Lejeune). Multiple samples of surface water, sediment, and worms were collected monthly. Analysis was performed on an extract of the sediments. This study found that iron and manganese levels varied temporally. Levels decreased in samples collected at or near the Atlantic Ocean. The highest concentrations of iron, manganese, and zinc occurred inland, in a station in the Newport River. At this station, the mean levels of iron in sediment extract were reported to range from 380 $\mu\text{g/g}$ to 1,800 $\mu\text{g/g}$,

while manganese ranged from 12 µg/g to 71 µg/g. Median level of iron in surface water was 300 µg/L, while manganese was 22 µg/L. The study found that iron was most abundant, followed by manganese.

According to a study of chemical characteristics of natural waters (Hem, 1992), iron and manganese can occur in water through natural effects. Hem cited a report that observed manganese at 1.0 mg/L small streams due to low dissolved oxygen levels. Hem also reported that manganese can occur in groundwater above 1.0 mg/L. Manganese can dissolve into groundwater from manganese oxide coatings on soil/sediment particles. Manganese is a significant constituent of many igneous and metamorphic rocks. Small amounts of manganese are commonly present in limestone and dolomite, substituting for calcium. Partially cemented limestone and calcareous sediments are common in the Camp Lejeune area, and were observed at Site 36.

Hem observed iron concentrations in surface water at 1.4 mg/L due to organic complexing. Typically, iron in surface water is on the order of 10 µg/L. Iron can occur in groundwater at levels as high as 50 mg/L given certain chemical conditions (a pH between 6 and 8 SU and a bicarbonate activity less than 61 mg/L). A high level of dissolved iron can occur with oxidation of ferrous sulfides. Sulfur is altered to sulfate releasing ferrous iron. Metallic sulfides are common in sedimentary and igneous rocks, or soils/sediments with those source rocks. Hem reported, "The availability of iron for aqueous solutions is strikingly affected by environmental conditions, especially changes in degree or intensity of oxidation or reduction.

5.4 References

Cross, Ford A., Duke, Thomas W., and James N. Willis. 1970. "Biogeochemistry of Trace Elements in a Coastal Plain Estuary: Distribution of Manganese, Iron, and Zinc in Sediments, Water, and Polychaetous Worms." Chesapeake Science. Vol. 11, No. 4, 221-234. December 1970.

Feenstra S., Cherry, J.A., and B.L. Parker. 1995. Dense Chlorinated Solvents in Groundwater: Background History of the Problem. July 1995.

Fetter, C.W. 1986. Applied Hydrogeology. Charles E. Merrill Publishing Co., Columbus, Ohio.

Ford and Gruba. 1984. Methods of Determining Relative Contaminant Mobilities and Migration Pathways Using Physical-Chemical Data.

Hem. 1992. Study of Interpretation of the Chemical Characteristics of Natural Waters. USGS Water-Supply Paper 22254.

Howard, Philip H. 1989. Handbook of Environmental Fate and Exposure Data for Organic Chemicals - Pesticides. Lewis Publishers. Chelsea, Michigan.

Howard, Philip H. 1990. Handbook of Environmental Fate and Exposure Data for Organic Chemicals - Large Production and Priority Pollutants. Lewis Publishers. Chelsea, Michigan.

Howard, Philip H. 1991. Handbook of Environmental Fate and Exposure Data for Organic Chemicals - Solvents. Lewis Publishers. Chelsea, Michigan.

Laskowski, D.A., Goring, C.A., McCall, P.J., and R.L. Swann. 1983. "Terrestrial Environment in Environmental Risk Analysis for Chemicals." Environmental Risk Analysis for Chemicals. R.A. Conways, ed., Van Nostrand Reinhold Company, New York, New York.

Lyman, W.J., Rechl, W.F., and D.H. Rosenblatt. 1982. Handbook of Chemical Property Estimation Methods. McGraw-Hill, Inc., New York.

Nichols. 1993. Principle of Subsurface Contaminant Fate and Transport Modeling.

Superfund Chemical Data Matrix (SCDM). 1991. United States Environmental Protection Agency Hazardous Site Evaluation Division. December 1991.

Swartbaugh, et al. "Remediating Sites Contaminated with Heavy Metals." Hazardous Materials Control. November/December 1992.

United States Environmental Protection Agency (USEPA). 1986. Superfund Public Health Evaluation Manual. Office of Emergency Response. Washington, D.C. October, 1986. EPA/540/1-86/060.

United States Department of Human and Health Services (USHHS). 1994. Toxicological Profile for 1,2-Dichloroethene. U.S. Department of Human and Health Services.

United States Department of Human and Health Services (USHHS). 1991 Toxicological Profile for Trichloroethene. U.S. Department of Human and Health Services.

United States Department of Human and Health Services (USHHS). 1990 Toxicological Profile for 1,2-Dichloroethene. U.S. Department of Human and Health Services.

SECTION 5.0 TABLES

TABLE 5-1

**ORGANIC PHYSICAL AND CHEMICAL PROPERTIES
SITE 86, HADNOT POINT BURN DUMP
REMEDIAL INVESTIGATION, CTO-0303
MCAS, NEW RIVER, NORTH CAROLINA**

Contaminants of Potential Concern	Vapor Pressure (mm Hg)	Water Solubility (mg/L)	Log K_{ow}	K_{oc}	Specific Gravity (g/cm ³)	Henry's Law Constant (atm-m ³ /mole)	Mobility Index
Volatiles							
1,2-Dichloroethene (cis)	208	3,500	0.70	49	-	7.59E-03	-
1,2-Dichloroethene (trans)	324	6,300	0.48	59	1.26	6.56E-03	2.9
Trichloroethene	57.9	1,100	2.38	126	1.46	9.1E-03	2.8
Benzene	95.2	1,750	2.12	83	0.879	5.59E-03	3.3
Tetrachloroethene	17.8	150	2.6	364	-	2.59E-02	-
Semivolatiles	5.0E-09	0.014	5.61	5.34	NA	1.00E-06	-15.50
Benzo(a)anthracene							
Benzo(a)pyrene	5.0E-09	0.0038	6.04	5.72	NA	4.90E-07	-16.40
Benzo(b)fluoranthene	1E-06 to 1E-07	0.009	6.57	6.26	NA	1.22E-06	-14.00
Dibenz(a,h)anthracene							
Indeno(1,2,3-cd)pyrene	1.0E-10	5.3E-04	6.51	6.20	1.070	6.95E-08	-19.50
Pesticides							
Dieldrin	1.78E-07	0.195	3.5	1700	1.75	4.58E-07	-10.7

Notes:

NA = Not Available

References:

Howard, 1989-1991
SCDM, 1991
USEPA, 1986 (SPHEM)

TABLE 5-2

RELATIVE MOBILITIES OF METALS AS A FUNCTION OF ENVIRONMENTAL CONDITIONS (Eh, pH)
 SITE 86, HADNOT POINT BURN DUMP
 REMEDIAL INVESTIGATION, CTO-0303
 MCAS, NEW RIVER, NORTH CAROLINA

Relative Mobility	Environmental Conditions			
	Oxidizing	Acidic	Neutral/ Alkaline	Reducing
Very high			Se	
High	Se, Zn	Se, Zn, Cu, Ni, Hg, Ag		
Medium	Cu, Ni, Hg, Ag, As, Cd	As, Cd	As, Cd	
Low	Pb, Ba, Se	Pb, Ba, Be	Pb, Ba, Be	
Very Low	Fe, Cr	Cr	Cr, Zn, Cu, Ni, Hg, Ag	Cr, Se, Zn, Cu, Ni, Hg, Pb, Ba, Be, Ag

Notes:

Se = Selenium	Cd = Cadmium
Zn = Zinc	Ba = Barium
Cu = Copper	Pb = Lead
Ni = Nickel	Fe = Iron
Hg = Mercury	Cr = Chromium
Ag = Silver	Be = Beryllium
As = Arsenic	Zn = Zinc

Source: Swartzbaugh, et al. "Remediating Sites Contaminated with Heavy Metals."
 Hazardous Materials Control, November/December 1992.

6.0 BASELINE HUMAN HEALTH RISK ASSESSMENT

The following subsections present the baseline human health risk assessment (BRA) conducted for Site 86, Aboveground Storage Tank (AST) Area. This assessment was performed in accordance with the USEPA document Risk Assessment Guidance for Superfund, Human Health Evaluation Manual: Part A (USEPA, 1989). The purpose of the BRA is to assess whether the contaminants of potential concern (COPCs) at the site pose a current or future risk to human health in the absence of remedial action. COPCs are site-related contaminants used to quantitatively estimate human exposures and associated potential health effects. Because the purpose of the risk assessment is to estimate the degree of risk to human health and to be protective of human health, the approach of the USEPA guidance is designed to be conservative. This protectiveness is achieved by the use of assumptions and models that result in upper bound estimates of risk, i.e., the true or actual risk is expected to fall between the estimated value and zero. As a result, the actual site risks are unlikely to exceed the estimated upper bound values and are probably lower than the calculated risk. The following paragraphs present a brief overview of the risk assessment process and how the assessment affects further activity at the sites.

For the BRA, both current and future land use exposure scenarios were assumed for the site. The current scenario reflects potential human exposure pathways to the COPCs that presently exist at the site (i.e., exposure pathways currently available). Likewise, the future use scenario represents exposure pathways that are conceivable in the future (e.g., residential development). The future use is typically determined by zoning and the environmental setting of the site. The development of current and future use exposure scenarios is consistent with the methodology for baseline risk assessment, as specified by USEPA.

The National Contingency Plan (NCP) stipulates a range of acceptable cancer risk levels of 1×10^{-4} to 1×10^{-6} for total risk at a hazardous waste site (USEPA, 1990). These cancer risk levels represent the probability of an individual developing cancer over his or her lifetime if exposed to the COPCs at the site. For example, a risk level of 1×10^{-6} is the probability that one person in 1,000,000 exposed persons will develop cancer in a lifetime. The total noncarcinogenic acceptable risk level is a hazard index of less than or equal to 1.0. This noncancer risk level depicts a level at or below which adverse systemic effects are not expected in the exposed population.

A remedial action is recommended when either the total cancer or noncancer risks are above the criteria established by the NCP. Some form of remedial action also is necessary when either the current or future exposure point concentrations at the site are above the applicable or suitable analogous standards (e.g., maximum contaminant levels [MCLs] for drinking water) for those COPCs for which standards exist. When a remedial action is necessary, applicable or relevant and appropriate requirements (ARARs) and/or risk-based cleanup levels are used in determining acceptable concentrations in the environmental media. No remedial response is required when the cancer and noncancer criteria and the ARARs are not exceeded.

6.1 Introduction

The BRA investigates the potential for COPCs to affect human health and/or the environment, both now and in the future, under a "no further remedial action scenario." The BRA process evaluates the data generated during the sampling and analytical phase of the RI, identifying areas of interest and COPCs with respect to geographical, demographic, and physical and biological characteristics of the study area. These, combined with the current understanding of physical and chemical

properties of the site-associated constituents (with respect to environmental fate and transport processes), are then used to estimate the concentrations of contaminants at the end points of logical exposure pathways. Finally, contaminant intakes by hypothetical receptors are determined and combined with the toxicological properties of the contaminants to estimate (inferentially) the potential public health impacts posed by constituents detected at the site.

The BRA for the site was conducted in accordance with current USEPA Risk Assessment Guidance (USEPA, 1989 and USEPA, 1991), and USEPA Region IV Supplemental Risk Guidance (USEPA, 1992c).

The components of the BRA include the following:

- Hazard Identification: determination as to whether a substance has the potential to elicit an adverse effect (toxicity) upon exposure to humans
- Exposure Assessment: identification of the human population(s) likely to be exposed and the development of specific exposure pathways for the population
- Toxicity Assessment: quantification of the relationship between the human exposure and the probability of occurrence (risk) of a toxic response
- Risk Characterization: development of a quantitative estimation of the potential risk from a combination of information collected during the exposure and toxicity assessment
- Uncertainty Analysis: identification and qualitative discussion of any major sources of uncertainty pertaining to the finding of the BRA
- Conclusions: summarization and conclusion of the results of the BRA relating to the total site risk are drawn

Each of these components of the BRA is discussed and addressed for the site in the following subsections. Introductory text is presented first, followed by a site-specific discussion. Referenced tables and figures are presented after the text portion of this section.

6.2 Hazard Identification

Data generated during the remedial investigation and previous studies at the site were used to draw conclusions and to identify data gaps in the BRA. The data were evaluated to assess which data were of sufficient quality to include in the risk assessment. The objective when selecting data to include in the risk assessment was to provide accurate and precise data to characterize contamination and evaluate exposure pathways.

6.2.1 Data Evaluation and Reduction

The initial hazard identification step entailed the validation and evaluation of the site data to determine its usability in the risk assessment. Validation was conducted by a independent third party (Heartland Environmental Services, Inc.). Validation of the analytical data is included to verify that proper quality assurance/quality control (QA/QC) was performed and that the corresponding

results were within the specified method control limits. This process resulted in the identification of COPCs for the site. During this validation and evaluation, data that would result in inaccurate conclusions (e.g., data that were rejected or attributed to blank contamination, as qualified by the validator) were reduced within the data set. Data reduction entailed the removal of unreliable data from the original data set based on the guidelines established by USEPA. A summary of the data quality was presented in Section 4.1, Data Quality.

6.2.2 Identification of Data Suitable for Use in a Quantitative Risk Assessment

To provide for accurate conclusions to be drawn from sampling results, analytical data were reviewed and evaluated. During this review and evaluation, data that would lead to inaccurate conclusions were reduced within each data set. This section presents the criteria that were used to review, reduce, and summarize the analytical data. These criteria are consistent with USEPA guidance for data reduction.

Three environmental media were investigated at the site during this RI: surface soils, subsurface soils, and shallow and deep groundwater. There were no surface water bodies of either human health and/or ecological significance present at this site. The surface soil and subsurface soil data were evaluated as single data sets. That is, the data were not segregated into areas of concern. Surface soil samples were collected from 0- to 12-inches, and subsurface soil from greater than 12-inches below ground surface. The shallow and deep aquifers were evaluated as a single unit, because it has been shown that there is interconnection between the shallow and deep aquifers (see Section 2.0 of this report); i.e., the two aquifers are not separated. Consequently, exposure to both sources of groundwater as one unit were evaluated. For Site 86, these media were assessed for potential risk to human receptors.

Data collected during the February to May, 1995, and October, 1995, sampling events were evaluated in this risk assessment. The previous investigations conducted at this site are detailed in Section 1.0 of this report.

Information relating to the nature and extent of contamination at the site is provided in Section 4.0 of this report. The discussion provided in Section 4.0 also was utilized in the selection of COPCs at the site. The reduced data sets for all media of concern at the site are provided in Appendices G and H of this report.

6.2.3 Criteria Used in Selection of COPCs

This section presents the selection of COPCs for the evaluation of potential human health risk. As exemplified by the data summary tables in Appendices G and H, the number of constituents positively detected at least once during the field investigation is large. Quantifying risk for all positively identified parameters may distract from the dominant risks presented by the site. Therefore, the data set (resulting data set after applying the criteria listed in the previous section) was reduced to a list of COPCs. As stated previously, COPCs are site-related contaminants used to quantitatively estimate human exposures and associated potential health effects.

The selection of the COPCs was based on a combination of detected concentrations; toxicity; frequency of detection; comparison to background values, including site-specific, base-specific and published ranges; and comparison of physiochemical properties, including mobility, persistence, and toxicity. In addition, historical information pertaining to past site activities was considered. USEPA

guidance states that a contaminant may not be retained for quantitative evaluation in the BRA if: (1) it is detected infrequently in an environmental medium (e.g., equal to or less than 5 percent for at least 20 samples per data set), (2) it is absent or detected at low concentrations in other media, or (3) site history does not provide evidence the contaminant to be present (USEPA, 1989). To qualitatively assess the COPCs, comparisons of results to federal and state criteria and Region III Risk-Based Concentrations (RBCs) (USEPA, 1995b) were used. A brief description of the selection criteria used in choosing final COPCs is presented below. A contaminant did not need to meet the criteria of all of these three categories in order to be retained as a COPC.

6.2.3.1 Site Setting

Site 86 is located on the southwest corner of the Foster and Campbell Street intersection, within the operations area of MCAS, New River. The site is comprised of a lawn area surrounded by buildings, asphalt roads, and parking lots. Concrete pylons, upon which electric and steam overhead utilities are mounted, line the northern, western, and southern boundaries of the site. Campbell Street borders the site to the north and Foster Street lies adjacent to the east. Immediately to the south of the study area is Building AS-502, the MCAS fire station. The entrance road to the fire station borders the study area to the west.

The ground surface at Site 86 gently slopes to the south, toward a drainage ditch and culvert. Storm water drains that are located along Campbell Street receive runoff from only the northernmost portion of the study area. Stormwater from Site 86 eventually discharges into the New River, which lies approximately three quarters of a mile to the east.

Site History

Site 86 served as a storage area for petroleum products from 1954 to 1988. In 1954, three 25,000-gallon ASTs were installed within an earthen berm. Additionally, a small pump house was constructed to transfer fuel oil to and from the ASTs. The three tanks were reportedly used for No.6 fuel oil storage until 1979. From 1979 to 1988 the tanks were then used for temporary storage of waste oil (O'Brien & Gere, 1992). The three tanks were emptied in 1988 and are believed to have been removed in 1992. Today, the former location of the tanks is grass-covered and only a very slight depression remains.

A preliminary site investigation was conducted in 1990 by Dewberry and Davis, Inc. Several VOCs were found in the subsurface soil, including chloroform, methylene chloride, 1,1,1-trichloroethane (TCA), and 1,1,2-trichlorofluoroethane. These detections were attributed to localized surface spills. In 1992, O'Brien and Gere conducted a site assessment, investigating soil and groundwater at this site. Soil samples were analyzed for TPH and TCLP compounds. Most of the samples showed detections that did not exceed regulatory criteria for these parameters.

In the groundwater, several organic compounds were detected: benzene, toluene, 1,1-dichloroethane (1,1-DCA), 1,2-dichloroethene (1,2-DCE), trichloroethene, tetrachloroethene (PCE), chloroethane, and TCA. The detections of benzene, PCE, and TCE exceeded North Carolina groundwater criteria in a few samples. Toluene and TCA were detected below the state groundwater criteria. There are no evaluation criteria available for chloroethane, 1,1-DCA, and 1,2-DCE.

Baker conducted the latest investigation at this site in 1995, addressing soil and groundwater. A preliminary assessment of the unvalidated data indicated the presence of VOCs (i.e., TCE, 1,2-dichloroethane [1,2-DCA], 1,2-DCE, benzene, and PCE) in soil and groundwater media.

6.2.3.2 Frequency of Detection

In general, constituents that were detected infrequently (e.g., equal to or less than 5 percent, when at least 20 samples of a medium are available) may be anomalies due to sampling or analytical errors or may be present simply in the environment due to past or current site activities. It should be noted, however, that detected constituents were individually evaluated prior to exclusion from the BRA. Physiochemical properties (i.e., fate and transport) and toxicological properties for each detected constituent were evaluated (see following sections).

6.2.3.3 Comparison to Background

Sample concentrations were compared to site-specific (i.e., twice the base-specific average concentration) background levels. Background information was available for soil media, but not groundwater media. The results of these comparisons are presented in Tables 6-1 and 6-2.

6.2.3.4 Physiochemical Properties

Mobility

The physical and chemical properties of a contaminant are responsible for its transport in the environment. These properties, in conjunction with site conditions, determine whether a contaminant will tend to volatilize into the air from surface soils or surface waters or be transported via advection or diffusion through soils, groundwaters, and surface waters. Physical and chemical properties also describe a contaminant's tendency to adsorb onto soil/sediment particles. Environmental mobility can correspond to either an increased or decreased potential to affect human health and/or the environment.

Persistence

The persistence of a contaminant in the environment depends on factors such as the microbial content of soil and water, organic carbon content, the concentration of the contaminant, climate, and the ability of the microbes to degrade the contaminant under site conditions. In addition, chemical degradation (i.e., hydrolysis), photochemical degradation, and certain fate processes such as sorption may contribute to the elimination or retention of a particular compound in a given medium.

6.2.3.5 Toxicity

The potential toxicity of a contaminant is an important consideration when selecting COPCs for further evaluation in the human health assessment. For example the weight-of-evidence (WOE) classification should be considered in conjunction with concentrations detected at the site. Some effects considered in the selection of COPCs include carcinogenicity, mutagenicity, teratogenicity, systemic effects, and reproductive toxicity. Bioaccumulation and bioconcentration properties may affect the severity of the toxic response in an organism and/or subsequent receptors and are evaluated if relevant data exist.

Despite their inherent toxicity, certain inorganic contaminants are essential nutrients. Essential nutrients need not be considered for further consideration in the quantitative risk assessment if they are present in relatively low concentrations (i.e., below twice the average base-specific background levels or slightly elevated above naturally occurring levels) or if the contaminant is toxic at doses much higher than those which could be assimilated through exposures at the site. Due to the difficulty of determining nutrient levels that were within acceptable dietary levels, only essential nutrients present at low concentrations (i.e., only slightly elevated above background) were eliminated from the BRA. Essential nutrients, however, were included in the ecological risk evaluation.

6.2.3.6 Contaminant Concentrations in Blanks

Sample concentrations were compared quantitatively to investigation-related blank concentrations. Sample concentrations of parameters that are typical laboratory or field contaminants (i.e., acetone, 2-butanone, methylene chloride, toluene, and phthalate esters) that exceeded blank concentrations by a factor of 10 and other parameter concentrations that exceeded blank concentrations by a factor of five were considered to be site related. Parameters not meeting this criteria were considered artifacts from field or laboratory practices and treated as non-detects.

For Site 86, the following organics were detected in the blanks: acetone (23 µg/L), 2-butanone (29 µg/L), chloroform (5 µg/L), and bis(2-ethylhexyl)phthalate (1 µg/L).

6.2.3.7 Federal and State Criteria and Standards

Contaminants detected at the site were compared to state and federal standards, criteria, and/or To Be Considered levels (TBCs). These comparisons may provide some qualitative information as to the relative potential for health impacts resulting from the site. It should be noted that COPC concentration ranges were directly compared to each standard/criteria/TBC. This comparison did not take into account the additive or synergistic effects of those constituents without standards or criteria. Consequently, conclusions regarding potential risk posed by each site cannot be inferred from this comparison. A brief explanation of the standards/criteria/TBCs used for the evaluation of COPCs is presented below.

North Carolina Water Quality Standards (NCWQSs) - Groundwater - NCWQSs are the maximum allowable concentrations resulting from any discharge of contaminants to the land or waters of the state, which may be tolerated without creating a threat to human health or which otherwise render the groundwater unsuitable for its intended purpose.

Maximum Contaminant Levels (MCLs) - Federal Groundwater Standards - 40 CFR 161 - MCLs are enforceable standards for public water supplies promulgated under the Safe Drinking Water Act and are designed for the protection of human health. MCLs are based on laboratory or epidemiological studies and apply to drinking water supplies consumed by a minimum of 25 persons. They are designed for prevention of human health effects associated with a lifetime exposure (70-year lifetime) of an average adult (70 kg) consuming 2 liters of water per day. MCLs also consider the technical feasibility of removing the contaminant from the public water supply.

Health Advisories (HAs) - HAs are guidelines developed by the USEPA Office of Drinking Water for nonregulated constituents in drinking water. These guidelines are designed to consider both acute and chronic toxic effects in children (assumed body weight 10 kg) who consume 1 liter of

water per day or in adults (assumed body weight 70 kg) who consume 2 liters of water per day. HAs are generally available for acute (1 day), subchronic (10 days), and chronic (longer-term) exposure scenarios. These guidelines are designed to consider only threshold effects and, as such, are not used to set acceptable levels of potential human carcinogens.

USEPA Region III COC Screening Values - COC screening values are derived using conservative USEPA promulgated default values and the most recent toxicological criteria available. COC screening values for potentially carcinogenic and noncarcinogenic chemicals are individually derived based on a target incremental lifetime cancer risk (ILCR) of 1×10^{-6} and a target hazard quotient of 0.1, respectively. For potential carcinogens, the toxicity criteria applicable to the derivation of COC screening values are oral and inhalation cancer slope factors; for non carcinogens, they are chronic oral and inhalation reference doses. These toxicity criteria are subject to change as more updated information and results from the most recent toxicological/epidemiological studies become available. Therefore, the use of toxicity criteria in the derivation of COC screening values requires that the screening concentrations be updated periodically to reflect changes in the toxicity criteria.

Since the most recent COC screening values table was issued by USEPA in October 1995, the values from these tables can be updated by incorporating information from another set of tables containing risk-based concentrations (RBCs) that are issued by USEPA Region III on a quarterly basis. The RBCs are derived using the same equations and USEPA promulgated default exposure assumptions that were used by Region III to derive the COC screening values. In addition, the quarterly RBCs for potentially carcinogenic chemicals are based on a target ILCR of 1×10^{-6} . The only difference in the derivation methodologies for the COC screening values and the RBCs is that the RBCs for noncarcinogens are based on a target hazard quotient of 1.0 rather than 0.1. The COC screening values for noncarcinogens are to be derived based on a target hazard quotient of 0.1, to account for cumulative risk from multiple chemicals in a medium. Re-derivation of the quarterly noncarcinogenic RBCs based on a target hazard quotient of 0.1, while using the most recent toxicological criteria available, results in a set of values that can be used, as a COC screening values. In other words, an updated set of COC screening values can be attained each quarter by using the carcinogenic RBCs issued quarterly by USEPA Region III and dividing the accompanying noncarcinogenic RBCs by a factor of 10.

North Carolina Water Quality Standards (Surface Water) - The NCWQSs for surface water are the standard concentrations that, either alone or in conjunction with other wastes in surface waters, will neither render waters injurious to aquatic life, wildlife, or public health, nor impair the waters for any designated use.

Ambient Water Quality Criteria - AWQCs are non-enforceable regulatory guidelines and are of primary utility in assessing acute and chronic toxic effects in aquatic systems. They may also be used for identifying the potential for human health risks. AWQCs consider acute and chronic effects in both freshwater and saltwater aquatic life, and potential carcinogenic and noncarcinogenic health effects in humans from ingestion of both water (2 liters/day) and aquatic organisms (6.5 grams/day), or from ingestion of water alone (2 liters/day). The human health AWQCs for potential carcinogenic substances are based on the USEPA's specified incremental cancer risk range of one additional case of cancer in an exposed population of 10,000,000 to 100,000 (i.e. the 10^{-7} to 10^{-5} range).

Sediment Screening Levels - Sediment Screening Levels (SSLs) have been compiled to evaluate the potential for contaminants in sediments to cause adverse health effects (Long, et.al, 1995; Long

and Morgan 1991; and, USEPA, 1995b). The lower ten percentile (Effects Range-Low [ER-L]) and the median percentile (Effects Range-Median [ER-M]) of biological effects have been developed for several contaminants. The concentration below the ER-L represents a minimal-effects range (adverse effects would be rarely observed). The concentration above the ER-L but below the ER-M represents a possible-effects range (adverse effects would occasionally occur). Finally, the concentration above the ER-M represents a probable-effects range (adverse effects would probably occur).

As stated previously, COPCs in all media of concern at the site were compared with these aforementioned criteria. The results of the standards/criteria/TBC comparison for the site are presented in Tables 6-1 through 6-3. The results are discussed in the following section.

6.2.4 Contaminants of Potential Concern (COPCs)

The following sections present an overview of the analytical data obtained for each medium and the subsequent retention or elimination of COPCs using the aforementioned criteria for selection of COPCs.

6.2.4.1 Surface Soil

In surface soil, the following contaminants (detected frequencies noted) were identified as COPCs: benzo(a)anthracene (56 percent), benzo(b)fluoranthene (44 percent), benzo(a)pyrene (56 percent), indeno(1,2,3-cd)pyrene (39 percent), dibenzo(a,h)anthracene (22 percent), dieldrin (91 percent), arsenic (82 percent), iron (100 percent), and vanadium (100 percent). These contaminants were detected frequently (i.e., greater than 5 percent) and exceeded the residential soil screening levels.

Three VOCs were detected in the 18 samples analyzed for these parameters. On comparison to Region III residential soil screening levels, acetone, toluene, and xylene were detected at maximum levels below the residential soil Screening levels. Consequently, VOCs were not retained as COPCs.

Twenty SVOCs were detected in the 18 samples analyzed for SVOCs. Five SVOCs were identified as COPCs, as noted above. On comparison to Region III residential soil screening levels, the following SVOCs were detected at maximum levels were below the screening levels: naphthalene, 2-methylnaphthalene, acenaphthene, dibenzofuran, fluorene, phenanthrene, anthracene, carbazole, fluoranthene, pyrene, butylbenzylphthalate, chrysene, bis(2-ethylhexyl)phthalate, benzo(k)fluoranthene, and benzo(g,h,i)perylene. Consequently, a majority of the SVOCs were not evaluated as COPCs.

Six pesticides were detected in the 11 samples analyzed for these parameters. One of these pesticides, dieldrin, was retained as a COPC. Aldrin, heptachlor epoxide, 4,4'-DDE, 4,4'-DDD, and 4,4'-DDT were detected at levels less than screening levels. Consequently, these pesticides were not evaluated as COPCs.

Nineteen metals were detected in the 11 samples analyzed for inorganics. Three of these metals were identified as COPCs, as noted previously. Aluminum, barium, cadmium, chromium, cobalt, copper, lead, manganese, mercury, nickel, selenium, and zinc were detected at levels less than the screening levels and were excluded from the evaluation. Essential nutrients also were excluded. In surface soil, these chemicals included calcium, magnesium, potassium, and sodium. These results are summarized in Table 6-1.

6.2.4.2 Subsurface Soil

In subsurface soil, the COPCs were identified as the following: aluminum, iron, and arsenic. These COPCs were detected frequently (i.e., aluminum and iron were detected 100 percent, and arsenic was detected in 81 percent of the samples) and exceeded residential soil screening levels. These results are summarized in Table 6-2.

Five VOCs were detected in the 23 soil samples analyzed for organics. Acetone and xylene were detected at levels less than the screening levels. Carbon disulfide, 2-butanone, and toluene were detected at frequencies less than 5 percent. As a result, no VOCs were identified as COPCs.

Six SVOCs were detected in the 23 soil samples analyzed for these parameters. Butylbenzylphthalate, chrysene, and bis(2-ethylhexyl)phthalate were detected at levels less than screening levels. Fluoranthene, pyrene, and benzo(b)fluoranthene were detected infrequently. Consequently, these six SVOCs were not evaluated.

Three pesticides were detected in 16 samples. The maximum concentrations of 4,4'-DDE, 4,4'-DDD, and 4,4'-DDT did not exceed Region III residential soil screening levels. Consequently, they were not included as COPCs.

Eighteen metals were detected in the 16 samples analyzed for inorganics. Three of these metals were selected as COPCs, as mentioned above. Antimony, barium, chromium, cobalt, copper, lead, manganese, nickel, selenium, vanadium, and zinc were detected at levels below the screening levels. Essential nutrients were excluded. In subsurface soil, these chemicals included calcium, magnesium, potassium, and sodium.

6.2.4.3 Shallow and Deep Groundwater

In the (combined) shallow and deep groundwater, the COPCs were identified as the following (detection frequencies are noted): 1,2-dichloroethene (total) (34 percent) trichloroethene (32 percent), benzene (17 percent), tetrachloroethene (10 percent), antimony (4 percent), arsenic (27 percent), iron (88 percent), lead (4 percent), and vanadium (4 percent). These COPCs were detected frequently and/or exceeded Region III tap water screening levels or criteria. These results are summarized in Table 6-3.

Six VOCs were detected in 41 samples. Four of the six VOCs were identified as COPCs. The remaining two VOCs, 1,1-dichloroethane and chloroform, were detected infrequently and excluded from evaluation.

Four SVOCs were detected in 23 samples. Naphthalene, dibenzofuran, fluorene, and di-n-butylphthalate were also detected infrequently and excluded from evaluation.

No pesticides or PCBs were detected in the groundwater. Therefore, no pesticides or PCBs were evaluated as COPCs.

Fourteen metals were detected in 26 samples. Although antimony, lead, and vanadium were detected infrequently, they were detected at levels greater than screening levels. As a result, these metals and iron and arsenic were included in the evaluation. On comparison of the maximum concentrations of the aluminum, barium, selenium, manganese, and zinc to the Region III tap water

screening levels, they did not exceed the screening levels. As a result, these contaminants were excluded from evaluation as COPCs. Essential nutrients were also excluded. These constituents include calcium, magnesium, potassium, and sodium.

6.3 Exposure Assessment

The exposure assessment addresses each potential exposure pathway via soil (surface and subsurface), groundwater, surface water, sediment, biota, and air. To determine if human exposure via these pathways may occur in the absence of remedial action, an analysis including the identification and characterization of exposure pathways was conducted. The following four elements were examined to determine if a complete exposure pathway was present:

- 1) a source and mechanism of chemical release
- 2) an environmental transport medium
- 3) a feasible receptor exposure route
- 4) a receptor exposure point

The exposure scenarios presented in the following sections are used to estimate individual risks. Unless otherwise noted, all the statistical data associated with the factors used in the dose evaluation equations for assessing exposure were obtained from the Exposure Factors Handbook (USEPA, 1989a) and the accompanying guidance manuals. A reasonable maximum exposure (RME) scenario was utilized in this assessment, which is consistent with USEPA Region IV recommendations regarding human health risk assessment. As a result, the exposure scenarios presented include RME assumptions for the input parameters in the dose evaluation equations. These values are summarized in Table 6-4.

6.3.1 Potential Human Receptors and Adjacent Populations

The following sections provide a discussion of the potential exposure pathways and receptors at Site 86.

6.3.1.1 Site Conceptual Model for Site 86

A site conceptual model of potential sources, migration pathways and human receptors was developed to encompass all current and future potential routes of exposure at the site. This document is presented in Appendix R. Figure 6-1 presents the potential exposure pathways and receptors for Site 86. Qualitative descriptions of current and future land use patterns in the vicinity of OU No.6 were provided in the model. All available analytical data and meteorological data were considered in addition to general understanding of the demographics of surrounding communities.

From this information, the following general list of potential receptors was developed for inclusion in the quantitative health risk analysis for Site 86:

- Current military personnel
- Current trespassers (child [age 1-6 years] and adult)
- Future on-site residents (child [age 1-6 years] and adult)
- Future construction worker

The following sections present a discussion of the potential exposure pathways and receptors at Site 86.

6.3.1.2 Current and Future Scenarios

Site 86 currently has no official uses. Access to the site is not limited. Consequently, trespassing onto the site is possible. Current receptors include on-site military personnel and trespassers (i.e., child and adult receptors). Exposure pathways for these receptors include surface soil incidental ingestion, dermal contact, and inhalation of fugitive dust.

At present, groundwater is not utilized for potable purposes. As a result, current groundwater exposure was not assessed. Exposure to subsurface soil in the current scenario is unlikely for the receptor population. Consequently, subsurface soil exposure was not considered to be viable.

In the future case, it is unlikely that a residential scenario will be implemented at the site. It is assumed that the present activities will continue into the foreseeable future. However, to be conservative, groundwater exposure to a residential child and adult receptor was assessed. Surface soil exposure, as calculated in the current scenario for the child and adult trespassers, is expected to remain the same in the future case.

Like the previous sites, groundwater exposure for future on-site military personnel was not assessed. However, a construction worker was evaluated in the future case. It was assumed that surface and subsurface soil exposure may occur as a result of excavation for potential construction activities at the site. In addition, subsurface soil exposure was assessed for future residents (i.e., child and adult receptor). The exposure pathways for these receptors are incidental ingestion, dermal contact, and inhalation.

6.3.2 Migration Exposure Pathways

In general, the migration of COPCs from site soil sources could potentially occur by the following routes:

- Vertical migration of potential contaminants from surficial soils to subsurface soils.
- Leaching of potential contaminants from subsurface soils to the water-bearing zones.
- Vertical migration from shallow water-bearing zones to deeper flow systems.
- Horizontal migration in groundwater in the direction of groundwater flow.
- Wind erosion and subsequent deposition of windblown dust.

The potential for a constituent to migrate spatially and persist in environmental media is important in the estimation of potential exposure. This section describes the potential exposure pathways presented on Figure 6-1 associated with each medium and each potential human receptor group, then qualitatively evaluates each pathway for further consideration in the quantitative risk analysis. Table 6-5 presents the potential human exposure scenarios for this site.

6.3.2.1 Surface Soil

The potential release source considered in the soil pathway was the chemical residuals in the surface soils. The release mechanisms considered were volatilization, fugitive dust generation/deposition,

leaching, and surface runoff. The transport media were the surface soils and air. The routes for human exposure to the contaminated soils included inhalation, ingestion, and dermal contact. Potential exposure points from the site were areas of human activity on and adjacent to the site.

Soil Ingestion and Dermal Contact

Incidental ingestion and dermal contact with surface soil in the current case are complete exposure pathways at Site 86. These exposure pathways were evaluated for the current military receptor and trespassers.

Soil Inhalation Via Volatilization

The soil represents a potential source of exposure at the site via volatilization of COPCs. The potentially exposed population includes current military personnel who may inhale contaminated air. However, no VOCs were identified as COPCs in either media at the site. No air samples were collected at this site. This pathway is not considered to be significant for the site and was not evaluated for the surface soils.

Soil Inhalation Via Fugitive Dust Generation

The surface soils in the current case and the subsurface soils in the future case represent a potential source of exposure at the site via fugitive dust generation from wind erosion and vehicular traffic on surface soils. Current military personnel, trespassers, future residents, and construction workers may inadvertently inhale the contaminated particulates as dust while engaging in outdoor activities.

6.3.2.2 Subsurface Soil

The potential release source considered in the subsurface soil pathway was the chemical residuals in the contaminated soils. The release mechanism considered was leaching to groundwater. The transport medium was the groundwater infiltrating the subsurface soil. Therefore, exposure to subsurface soils would be indirect (i.e., leaching of contaminants to groundwater). As such, subsurface soil exposure was addressed in the groundwater pathway analysis. Additionally, subsurface soil exposure was mentioned as part of the soil medium. It was assumed that the subsurface soil would be excavated and used as surface grading, landscaping, etc., in the foreseeable future. As a result, exposure to subsurface soil via ingestion, dermal contact, and inhalation was evaluated for the future construction worker and child and adult receptor. It was assumed that this exposure would result from outdoor activities.

6.3.2.3 Groundwater

The potential release source considered in evaluating the groundwater pathway was contaminated soils. The release mechanism considered was soil leaching. The transport medium was the groundwater. The routes considered for human exposure to the groundwater were direct ingestion of groundwater, dermal contact during showering, and inhalation of volatilized contaminants during showering.

Residences located on-site in the future scenario were considered to be potential exposure points. At present, on-site groundwater is not potable. As a result, groundwater from on-site sources is not significant and was not evaluated for potential risk in the current scenario. In the future scenario,

it is conservatively assumed that a potable well will be installed on-site. However, as stated previously, it is not expected that this residential scenario will be implemented in the future at these military sites. As a result, future groundwater risks on-site were assessed conservatively in accordance with guidance.

6.3.2.4 Surface Water

There were no surface water bodies of concern at this site. As a result, exposure to this medium was not evaluated.

6.3.2.5 Sediment

There were no surface water bodies of concern at this site. As a result, exposure to this medium was not evaluated.

6.3.2.6 Air

There are two potential release mechanisms to be considered in evaluating the atmospheric pathway: release of contaminated particulates (i.e., fugitive dust generation) and volatilization of contaminants from soil and groundwater. The transport mechanism is the air, and the potential exposure points are the areas of human activity on and adjacent to the site.

Fugitive Dust Generation

This air pathway was evaluated as a source of exposure outdoors at the site via fugitive dust generation of contaminants. Air exposure may occur when surface soils become airborne due to wind erosion or vehicular traffic. It is assumed that military personnel, child and adult receptors, and construction workers may inhale soil particulates while engaging in outdoor activities. This is applicable for both the current and future cases. This exposure pathway was previously discussed for the surface and subsurface soil in Sections 6.3.2.1 and 6.3.2.2, respectively.

Volatilization

The air pathway, specifically, volatilization of contaminants from groundwater, is a source of exposure at Site 86. It is assumed in the future scenario that an adult and child receptor will inhale volatilized contaminants present in groundwater while showering. This pathway is further discussed in Section 6.3.2, Exposure Pathways, under Groundwater. Also, see the section on Surface Soil for a discussion of the volatilization of contaminants from surface soil.

6.3.2.7 Aquatic Biota

There were no surface water bodies of concern at this site. As a result, exposure to this medium was not evaluated.

6.3.3 **Quantification of Exposure**

The concentrations used in the estimation of chronic daily intakes (CDIs) must be representative of the type of exposure being considered. Exposure to groundwater can occur discretely or at a number of sampling locations. This medium is transitory in that concentrations change frequently over time.

Averaging transitory data obtained from multiple locations is difficult and requires many more data points at discrete locations than exist within this site. As a result, the best way to represent groundwater contaminants from an exposure standpoint is to use a representative exposure concentration. Soils are less transitory than the aforementioned media and in most cases, exposure occurs over a wider area (i.e., residential exposure). Therefore, an upper confidence interval was used to represent a soil exposure concentration. Soil data collected from each of these areas was used separately in estimating the potential human health risks under current and future exposure scenarios. The human health assessment for future groundwater use considered groundwater data collected from all of the monitoring wells within a site and estimated risks to individuals per area of concern.

The manner in which environmental data are represented depends on the number of samples and sampling locations available for a given area and a given medium. Ninety-fifth percent (95%) upper confidence limit (UCL) values of the arithmetic mean for a lognormal distribution were used as exposure point concentrations for surface, subsurface soil, groundwater, surface water, and sediment. The 95 percent UCL for the lognormal distribution, rather than the normal distribution, was used for each contaminant in a given data set for quantifying potential exposure, because the lognormal distribution is more conservative than the normal distribution. For exposure areas with limited amounts of data or extreme variability in measured data, the 95 percent UCL can be greater than the maximum measured concentration; therefore, in cases where the 95 percent UCL for a contaminant exceeds the maximum detected value in a given data set, the maximum result was used in the estimate of exposure of the 95 percent UCL. However, the true mean may still be higher than this maximum value (i.e., the 95 percent UCL indicates a higher mean is possible), especially if the most contaminated portion of the site has not been sampled.

The 95 percent UCL of the lognormal distribution was calculated using the following equation (USEPA, 1992b):

$$UCL = e^{(\bar{x} + sH/\sqrt{n-1})}$$

where:

UCL	=	upper confidence limit
e	=	constant (base of the natural log, equal to 2.718)
x	=	mean of the transformed data
s	=	standard deviation of the transformed data
H	=	H-statistic
n	=	number of samples

The following criteria were used to calculate media-specific average concentrations for each parameter that was detected at least once:

- For results reported as "non-detect" (e.g., ND, U, etc.), a value of one-half of the sample-specific detection limit was used to calculate the mean. The use of one-half the detection limit commonly is assigned to non-detects when averaging data for risk assessment purposes, since the actual value could be between zero and a value just below the detection limit.

- Reported concentrations that were less than the detection limit were used to calculate the mean. Typically, these values are qualified with a "J" meaning that the value was estimated.
- The organic analytical results qualified with a "B" were not retained in the data set. The "B" qualifier means that the detected concentration was less than either five times or ten times the blank concentration (i.e., the 5-10 rule), depending upon the parameter. Common laboratory contaminants, such as phthalate esters, toluene, methylene chloride, methyl ethyl ketone, and acetone, follow the five times rule, while all other parameters follow the ten times rule (USEPA, 1989).
- Reported concentrations qualified with "R" were excluded from the data set. The data flag "R" means that the QA/QC data indicated that analytical results were not usable for quantitative purposes.

The reduced data were summarized by medium and analytical parameter type (i.e., organics and inorganics) for the site. For each parameter detected during the sampling programs, the frequency of detection, maximum concentration, minimum concentration, average (arithmetic mean) concentration, and both the normal and lognormal upper 95 percent level for the arithmetic average were summarized. This information is presented in Appendix H. It should be noted that the number of times analyzed may differ per parameter per media per area of concern. This is primarily due to data rejected due to QA/QC problems and excluded from the data set. Consequently, these data are not reflected in the number of times analyzed. Data and frequency summaries and statistical summaries are presented in Appendices G and H, respectively.

To estimate exposure from the inhalation of volatile contaminants in groundwater while showering, the "Integrated Household Exposure Model for Use of Tap Water Contaminated with Volatile Organic Chemicals," developed by S.A. Foster and P.C. Chrostowski (1987), was applied. To evaluate the health effects of lead, the USEPA lead uptake/biokinetic model was used. The model addresses the lowest age groups because children are exceptionally sensitive to the adverse effects of lead. These models are presented in Appendices P and Q.

6.3.4 Calculation of Chronic Daily Intakes

In order to numerically estimate the risks for current and future human receptors at Site 86, a CDI must be estimated for each COPC in every retained exposure pathway. Appendix S contains the specific CDI equations for each exposure scenario of interest. These equations were obtained from USEPA guidance (USEPA, 1989).

The following paragraphs present the general equations and input parameters used in the calculation of CDIs for each potential exposure pathway. Input parameters were taken from USEPA's default exposure factors guidelines where available and applicable. All inputs not defined by USEPA were derived from USEPA documents concerning exposure or from best professional judgment. All exposure assessments incorporate the representative contaminant concentrations in the estimation of intakes. Therefore, only one exposure scenario was developed for each exposure route/receptor combination.

CDIs for carcinogenic effects incorporate terms to represent the exposure duration (years) over the course of a lifetime (70 years or 25,550 days) (USEPA, 1989). Noncarcinogenic CDIs, on the other hand, were estimated using the concept of an average annual exposure. The intake incorporates terms describing the exposure time and/or frequency representing the number of hours per day and the number of days per year that exposure occurs. In general, noncarcinogenic CDIs for many exposure routes (e.g., soil ingestion) are greater for children than adults because of the differences in body weights, similar exposure frequencies, and higher ingestion rates.

Future residential exposure scenarios consider 1 to 6 year old children weighing 15 kg and adults weighing 70 kg on average (USEPA, 1989). For current military personnel, an exposure duration of 4 years was used to estimate a military residence. A one-year duration was used for future construction worker exposure scenarios.

6.3.4.1 Incidental Ingestion of Soil

The CDI for COPCs detected in soil was estimated for all potential human receptors and was expressed as:

$$CDI = \frac{C \times IR \times CF \times Fi \times EF \times ED}{BW \times AT}$$

Where:

C	=	Contaminant concentration in soil (mg/kg)
IR	=	Ingestion rate (mg/day)
CF	=	Conversion factor (1×10^{-6} kg/mg)
Fi	=	Fraction ingested from source (dimensionless)
EF	=	Exposure frequency (days/year)
ED	=	Exposure duration (years)
BW	=	Body weight (kg)
AT	=	Averaging time (days)

The following paragraphs discuss the exposure assumptions used in the estimation of exposure to COPCs associated with the potential ingestion of soils.

Military Personnel

During the course of daily activities at Site 86, military personnel could potentially be exposed to COPCs by the incidental ingestion of surface soils. The IR for military personnel exposed to surficial soils was assumed to be 100 mg/day (USEPA, 1989), and the fraction ingested was assumed to be 100 percent. An exposure frequency (EF) of 250 days per year was used in conjunction with an exposure duration of 4 years (USEPA, 1991). An averaging time (AT) of 70 years or 25,550 days was used for exposure to potentially carcinogenic compounds while an averaging time of 1,460 (4 years x 365 days/year) days was used for noncarcinogenic exposures.

Trespassers

Trespassers could potentially be exposed to COPCs in the surficial soils. Children and adults could potentially be exposed to COPCs in soils by incidental ingestion via hand to mouth contact. Ingestion rates (IR) for adults and children in this scenario were assumed to be 100 mg/day and

200 mg/day, respectively. EFs for both receptor groups were assumed to be 130 days/year (child) and 43 days/year (adult) (USEPA, 1992). The residential exposure duration (ED) was divided into two parts. First, a six-year exposure duration was evaluated for young children which accounts for the period of highest soil ingestion (200 mg/day), and second a 30-year exposure was assessed for older children and adults by using a lower soil ingestion rate (100 mg/day) (USEPA, 1991). Averaging times of 25,550 days for potential carcinogens and 10,950 days (30 years x 365 days/year) for noncarcinogenic constituents was used for estimating potential CDIs for adults. An AT of 2,190 days (6 years x 365 days/year) was used to estimate potential CDIs for children potentially exposed to noncarcinogens.

Future On-Site Residents

Future on-site residents could potentially be exposed to COPCs in the surficial soils during recreational or landscaping activities around their homes. Children and adults could potentially be exposed to COPCs in soils by incidental ingestion via hand to mouth contact. Ingestion rates (IR) for adults and children in this scenario were assumed to be 100 mg/day and 200 mg/day, respectively. EFs for both receptor groups were assumed to be 350 days per year (USEPA, 1991). The residential exposure duration (ED) was divided into two parts. First, a six-year exposure duration was evaluated for young children which accounts for the period of highest soil ingestion (200 mg/day), and second a 30-year exposure was assessed for older children and adults by using a lower soil ingestion rate (100 mg/day) (USEPA, 1991). Averaging times of 25,550 days for potential carcinogens and 10,950 days (30 years x 365 days/year) for noncarcinogenic constituents was used for estimating potential CDIs for adults. An AT of 2,190 days (6 years x 365 days/year) was used to estimate potential CDIs for children potentially exposed to noncarcinogens.

Future Construction Worker

During excavation activities, construction workers may be exposed to COPCs through the incidental ingestion of subsurface soil. The IR for future construction workers exposed to subsurface soils was assumed to be 480 mg/day (USEPA, 1991). An exposure frequency of 90 days per year was used in conjunction with an exposure duration of one year (USEPA, 1991). An adult BW of 70 kg was used.

A summary of the exposure factors used in the estimation of soil CDIs associated with incidental ingestion is presented in Table 6-4.

6.3.4.2 Dermal Contact with Soil

Chronic daily intakes associated with potential dermal contact of soils containing COPCs were expressed using the following equation:

$$CDI = \frac{C \times CF \times SA \times AF \times ABS \times EF \times ED}{BW \times AT}$$

Where:

C	=	Contaminant concentration in soil (mg/kg)
CF	=	Conversion factor (kg/mg)
SA	=	Skin surface available for contact (cm ²)
AF	=	Soil to skin adherence factor (1.0 mg/cm ²)

ABS	=	Absorption factor (dimensionless) - 0.01 for organics, 0.001 inorganics (USEPA, Region IV, 1992a and 1992d)
EF	=	Exposure frequency (days/year)
ED	=	Exposure duration (years)
BW	=	Body weight (kg)
AT	=	Averaging time (days)

The following paragraphs discuss the exposure assumptions used in the estimation of exposure to COPCs from dermal contact with soils.

Military Personnel

There is a potential for base personnel to absorb COPCs by dermal contact. The exposed skin surface area (4,300 cm²) was limited to the head (1,180 cm²), arms (2,280 cm²), and hands (840 cm²) (USEPA, 1992). Values for exposure duration (ED), exposure frequency (EF), body weight (BW), and averaging time (AT) were the same as those used for the incidental ingestion of soil scenario. The values for AF and ABS were provided above and are in accordance with USEPA and Region IV guidance.

Trespassers

Trespassers could also be potentially exposed to COPCs in on-site soil through dermal contact. Skin surface areas (SA) used in the on-site resident exposure scenario were developed for a reasonable worst case scenario for an individual wearing a short-sleeved shirt, shorts, and shoes. The exposed skin surface area was limited to the head, hands, forearms, and lower legs. Thus, applying 25 percent of the mean total body surface area (20,000 cm²) results in 5,000 cm² for adults. The exposed skin surface for a child (2,000 cm²) was estimated from the average of the 50th (0.866 m²) percentile body surface for a six year old child multiplied by 25 percent (USEPA, 1992). Exposure duration, exposure frequencies, body weights, and averaging times were the same as those discussed for the incidental ingestion scenario presented previously. The values for AF and ABS were provided above and are in accordance with USEPA and Region IV guidance.

Future On-Site Residents

Future on-site residents could also be potentially exposed to COPCs in on-site soil through dermal contact experienced during activities near their homes. Skin surface areas (SA) used in the on-site resident exposure scenario were developed for a reasonable worst case scenario for an individual wearing a short-sleeved shirt, shorts, and shoes. The exposed skin surface area was limited to the head, hands, forearms, and lower legs. Thus, applying 25 percent of the upper bound total body surface area (23,000 cm²) results in a default of 5,800 cm² for adults. The exposed skin surface for a child (2,300 cm²) was estimated using an average of the 50th (0.866 m²) and the 95th (1.06 m²) percentile body surface for a six year old child multiplied by 25 percent (USEPA, 1992). Exposure duration, exposure frequencies, body weights, and averaging times were the same as those discussed for the incidental ingestion scenario presented previously. The values for AF and ABS were provided above and are in accordance with USEPA and Region IV guidance.

Future Construction Worker

Dermal contact with subsurface soil COPCs could potentially occur during excavation activities. Skin surface area (SA) used for the construction worker exposure scenario were developed for an individual wear a short-sleeved shirt, long pants, and boots. The exposed skin surface area (4,300 cm²) was limited to the head (1,180 cm²), arms (2,280 cm²), and hands (840 cm²) (USEPA, 1992). The exposure frequency and exposure duration are the same as those discussed for incidental ingestion of subsurface soil. The values for AF and ABS were provided above and are in accordance with USEPA and Region IV guidance.

A summary of the soil exposure assessment input parameters for dermal contact is presented in Table 6-4.

6.3.4.3 Inhalation of Fugitive Particulates

Exposure to fugitive particulates was estimated for base personnel, trespassers, future residents, and construction workers. These populations may be exposed during daily recreational or work-related activities. The chronic daily intake of contaminants associated with the inhalation of particulates was estimated using the following equation:

$$CDI = \frac{C \times IR \times ET \times EF \times ED \times 1/PEF}{BW \times AT}$$

Where:

C	=	Contaminant concentration in soil (mg/kg)
IR	=	Inhalation rate (m ³ /day)
EF	=	Exposure frequency (days/year)
ED	=	Exposure duration (years)
1/PEF	=	Particulate emission factor, 1/(1.32x10 ⁹) (m ³ /kg)
BW	=	Body weight (kg)
AT	=	Averaging time (days)

The PEF relates the concentration in soil with the concentration of respirable particles in the air from fugitive dust emission. This relationship is derived by Cowherd (1985). The particulate emissions from contaminated sites are caused by wind erosion, and, therefore, depend on erodibility of the surface material. A default PEF, 1.32x10⁹, obtained from USEPA guidance to be published in late 1995 (per phone conversation with Janine Dinan of USEPA, USEPA, 1995c), was used in this assessment. The following paragraphs discuss the exposure assumptions used in the estimation of exposure to COPCs from the inhalation of particulates.

Military Personnel

During work related activities, military personnel may inhale COPCs emitted as fugitive dust. An inhalation rate 30 m³/day was used for military personnel (USEPA, 1991). Values for exposure duration, exposure frequency, body weight, and averaging time were the same as those used for the incidental ingestion scenario.

Trespassers

Trespassers may also inhale particulates. Inhalation rates (IR) used in this exposure scenario were 20 m³/day and 15 m³/day for adults and children, respectively (USEPA, 1989). Exposure frequencies, duration, body weights, and averaging time were the same as those used for the incidental ingestion scenario. Table 6-4 presents the exposure factors used to estimate CDIs associated with the particulate inhalation scenario.

Future On-Site Residents

Future on-site residents may also inhale particulates. Inhalation rates (IR) used in the on-site resident exposure scenario were 20 m³/day and 15 m³/day for adults and children, respectively (USEPA, 1989). Exposure frequencies, duration, body weights, and averaging time were the same as those used for the incidental ingestion scenario. Table 6-4 presents the exposure factors used to estimate CDIs associated with the particulate inhalation scenario.

Future Construction Worker

Future construction workers could become exposed to subsurface soil particulates during excavation activities. The inhalation rate (IR) used was 20 m³/day (USEPA, 1989). Exposure frequencies, duration, body weight, and averaging time were the same as those used for the soil incidental ingestion scenario. Table 6-4 presents the exposure factors used to estimate CDIs associated with the particulate inhalation scenario.

6.3.4.4 Ingestion of Groundwater

As stated previously, shallow groundwater is not currently being used as a potable supply at Site 86. Development of the shallow aquifer for potable use is unlikely because of its general water quality and poor flow rates. However, residential housing could be constructed in the future and groundwater used for potable purposes.

The CDI of contaminants associated with the future potential consumption of groundwater was estimated using the following general equation:

$$CDI = \frac{C \times IR \times EF \times ED}{BW \times AT}$$

Where:

C	=	Contaminant concentration in groundwater (mg/L)
IR	=	Ingestion rate (L/day)
EF	=	Exposure frequency (days/year)
ED	=	Exposure duration (years)
BW	=	Body weight (kg)
AT	=	Averaging time (days)

The following paragraphs discuss the exposure assumptions used in the estimation of exposure to COPCs from the ingestion of groundwater.

Future On-Site Residents

Exposure to COPCs via ingestion of groundwater was retained as a potential future exposure pathway for both children and adults. An IR of 1.0 L/day was used for the amount of water consumed by a 1 to 6 year old child weighing 15 kg. The adult receptor IR was 2.0 L/day. This ingestion rate provides a conservative exposure estimate (for systemic, noncarcinogenic toxicants) designed to protect young children who may be more affected than adolescents, or adults. This value assumes that children obtain all the tap water they drink from the same source for 350 days/year (which represents the exposure frequency [EF]). An averaging time (AT) of 2,190 days (6 years x 365 days/year) is used for noncarcinogenic compound exposure. The ingestion rate (IR) for adults was 2 liters/day (USEPA, 1989a). The ED used for the estimation of adult CDIs was 30 years (USEPA, 1989), which represents the national upper-bound (90th percentile) time at one residence. The averaging time for noncarcinogens was 10,950 days. An averaging time (AT) of 25,550 days (70 years x 365 days/year) was used to evaluate exposure for both children and adults to potential carcinogenic compounds. Table 6-4 presents a summary of the input parameters for the ingestion of groundwater scenarios.

6.3.4.5 Dermal Contact with Groundwater

The CDI associated with the dermal contact with groundwater was estimated using the following general equation:

$$CDI = \frac{C \times SA \times PC \times ET \times EF \times ED \times CF}{BW \times AT}$$

Where:

C	=	Contaminant concentration in groundwater (mg/L)
SA	=	Surface area available for contact (cm ²)
PC	=	Dermal permeability constant (cm/hr)
ET	=	Exposure time (hour/day)
EF	=	Exposure frequency (days/year)
ED	=	Exposure duration (years)
CF	=	Conversion factor (1 L/1000 cm ³)
BW	=	Body weight (kg)
AT	=	Averaging time (days)

The following paragraphs discuss the exposure assumptions used in the estimation of exposure to COPCs from dermal contact with groundwater.

Future On-Site Residents

Children and adults could contact COPCs through dermal contact with groundwater while bathing or showering. It was assumed that bathing would take place 350 days/year using site groundwater as the sole source. The whole body skin surface area (SA) available for dermal absorption was estimated to be 10,000 cm² for children and 23,000 cm² for adults (USEPA, 1992). The permeability constant (PC) reflects the movement of a chemical across the skin and into the blood stream. The permeability of a chemical is an important property in evaluating actual absorbed dose, yet many compounds do not have literature PC values. For contaminants in which a PC value has not been established, the permeability constant was calculated (see Appendix P). An exposure time (ET) of

0.25 hour/day was used to conservatively estimate the duration of bathing or showering (USEPA, 1989). The exposure duration, body weight, and averaging time were the same as those used for the ingestion of groundwater scenario. Table 6-4 presents the exposure factors used to estimate CDIs associated with the future dermal contact with COPCs in groundwater.

6.3.4.6 Inhalation of Volatile Organics While Showering

In order to quantitatively assess the inhalation of contaminants volatilized from shower water, the model developed by Foster and Chrostowski (Foster, 1987) was utilized (see Appendix P). Contaminant concentrations in air were modeled by estimating the following: the rate of chemical releases into air (generation rate), the buildup of VOCs in the shower room air while the shower was on, the decay of VOCs in the shower room after the shower was turned off, and the quantity of airborne VOCs inhaled while the shower was both on and off. The contaminant concentrations calculated to be in the air were then used as the concentration term.

The CDIs associated with the inhalation of airborne (vapor phase) VOCs from groundwater while showering were estimated using the following general equation:

$$CDI = \frac{C \times IR \times ET \times EF \times ED}{BW \times AT}$$

Where:

C	=	Contaminant concentration in air (mg/m ³)
IR	=	Inhalation rate (m ³ /hr)
ET	=	Exposure time (hr/day)
EF	=	Exposure frequency (days/year)
ED	=	Exposure duration (years)
BW	=	Body weight (kg)
AT _c	=	Averaging time carcinogen (days)
AT _{nc}	=	Averaging time noncarcinogen (days)

Future On-Site Residents

Both children and adults could inhale vaporized volatile organic COPCs during showering. It was assumed that showering would take place 350 days/year, using site groundwater as the sole source, for children weighing 15 kg, and adults weighing 70 kg (USEPA, 1989). An inhalation rate of 0.6 m³/hr was used for both receptors (USEPA, 1989). An exposure time of 0.25 hrs/day was used for both receptors (USEPA, 1989). The exposure duration and averaging times remained the same as for groundwater ingestion. Table 6-4 presents the exposure factors used to estimate CDIs associated with the inhalation of VOCs from groundwater while showering.

6.4 Toxicity Assessment

The purpose of this section is to define the toxicological values used to evaluate the exposure to the COPCs identified in Section 6.2.4. A toxicological evaluation characterizes the inherent toxicity of a compound. It consists of the review of scientific data to determine the nature and extent of the potential human health and environmental effects associated with exposure to various contaminants.

Human data from occupational exposures are often insufficient for determining quantitative indices of toxicity because of uncertainties in exposure estimates and inherent difficulties in determining causal relationships established by epidemiological studies. For this reason, animal bioassays are conducted under controlled conditions and their results are extrapolated to humans. There are several stages to this extrapolation. First, to account for species differences, conversion factors are used to extrapolate from test animals to humans. Second, the relatively high doses administered to test animals must be extrapolated to the lower doses more typical of human exposures. For potential noncarcinogens, safety factors and modifying factors are applied to animal results when developing acceptable human doses. For potential carcinogens, mathematical models are used to extrapolate effects at high doses to effects at lower doses. Epidemiological data can be used for inferential purposes to establish the credibility of the experimentally derived indices.

The available toxicological information indicates that many of the COPCs have both potential carcinogenic and noncarcinogenic health effects in humans and/or experimental animals. Although the COPCs may cause adverse health and environmental impacts, dose-response relationships and the potential for exposure must be evaluated before the risk to receptors can be determined. Dose-response relationships correlate the magnitude of the dose with the probability of toxic effects, as discussed in the following section.

An important component of the risk assessment is the relationship between the dose of a compound (amount to which an individual or population is potentially exposed) and the potential for adverse health effects resulting from the exposure to that dose. Dose-response relationships provide a means by which potential public health impacts may be evaluated. The published information on doses and responses is used in conjunction with information on the nature and magnitude of exposure to develop an estimate of risk.

Standard carcinogenic slope factors (CSFs) and/or reference doses (RfDs) have been developed for many of the COPCs. This section provides a brief description of these parameters.

6.4.1 Carcinogenic Slope Factor

CSFs are used to estimate an upper-bound lifetime probability of an individual developing cancer as a result of exposure to a particular level of a potential carcinogen (USEPA, 1989). This factor is generally reported in units of $(\text{mg}/\text{kg}/\text{day})^{-1}$ and is derived through an assumed low-dosage linear multistage model and an extrapolation from high to low dose-responses determined from animal studies. The value used in reporting the slope factor is the upper 95th percent confidence limit.

These slope factors are also accompanied by USEPA weight-of-evidence (WOE) classifications, which designate the strength of the evidence that the COPC is a potential human carcinogen.

In assessing the carcinogenic potential of a chemical, the Human Health Assessment Group (HHAG) of USEPA classifies the chemical into one of the following groups, according to the weight of evidence from epidemiologic and animal studies:

- Group A** - **Human Carcinogen** (sufficient evidence of carcinogenicity in humans)
- Group B** - **Probable Human Carcinogen** (B1 - limited evidence of carcinogenicity in humans; B2 - sufficient evidence of

		carcinogenicity in animals with inadequate or lack of evidence in humans)
Group C	-	Possible Human Carcinogen (limited evidence of carcinogenicity in animals and inadequate or lack of human data)
Group D	-	Not Classifiable as to Human Carcinogenicity (inadequate or no evidence)
Group E	-	Evidence of Noncarcinogenicity for Humans (no evidence of carcinogenicity in adequate studies)

6.4.2 Reference Dose

The RfD is developed for chronic and/or subchronic human exposure to chemicals and is based solely on the noncarcinogenic effects of chemical substances. It is defined as an estimate of a daily exposure level for the human population, including sensitive populations, that is not likely to cause an appreciable risk of adverse effects during a lifetime. The RfD is usually expressed as dose (mg) per unit body weight (kg) per unit time (day). It is generally derived by dividing a no-observed-(adverse)-effect-level (NOAEL or NOEL) or a lowest observed-adverse-effect-level (LOAEL) for the critical toxic effect by an appropriate uncertainty factor (UF). Effect levels are determined from laboratory or epidemiological studies. The UF is based on the availability of toxicity data.

UFs usually consist of multiples of 10, where each factor represents a specific area of uncertainty naturally present in the extrapolation process. These UFs are presented below and were taken from the Risk Assessment Guidance Document for Superfund, Volume I, Human Health Evaluation Manual (Part A) (USEPA, 1989):

- A UF of 10 is to account for variation in the general population and is intended to protect sensitive populations (e.g., elderly, children).
- A UF of 10 is used when extrapolating from animals to humans. This factor is intended to account for the interspecies variability between humans and other mammals.
- A UF of 10 is used when a NOAEL derived from a subchronic instead of a chronic study is used as the basis for a chronic RfD.
- A UF of 10 is used when a LOAEL is used instead of a NOAEL. This factor is intended to account for the uncertainty associated with extrapolating from LOAELs to NOAELs.

In addition to UFs, a modifying factor (MF) is applied to each reference dose and is defined as:

- A MF ranging from >0 to 10 is included to reflect a qualitative professional assessment of additional uncertainties in the critical study and in the entire data base for the chemical not explicitly addressed by the preceding uncertainty factors. The default for the MF is 1.

Thus, the RfD incorporates the uncertainty of the evidence for chronic human health effects. Even if applicable human data exist, the RfD still maintains a margin of safety so that chronic human health effects are not underestimated.

Toxicity factors and the USEPA WOE classifications are presented in Table 6-6. The hierarchy (USEPA, 1989) for choosing these values was as follows:

- Health Effects Assessment Summary Table (HEAST, USEPA, 1995)
- Integrated Risk Information System (IRIS, USEPA, 1995a)

The IRIS data base is updated monthly and contains both verified CSFs and RfDs. The USEPA has formed the Carcinogen Risk Assessment Verification Endeavor (CRAVE) Workgroup to review and validate toxicity values used in developing CSFs. Once the slope factors have been verified via extensive peer review, they appear in the IRIS data base. Like the CSF Workgroup, the USEPA has formed a RfD Workgroup to review existing data used to derive RfDs. Once the reference doses has been verified, they also appear in IRIS.

HEAST on the other hand, provides both interim (unverified) and verified CSFs and RfDs. This document is published quarterly and incorporates any applicable changes to its data base.

Toxicity values will be obtained primarily from the Region III Risk-Based Concentration Table, which is based on IRIS, HEAST and provisional and/or recommended USEPA toxicity values, in accordance with Region IV recommendations.

For some chemicals, there are no USEPA-verified toxicity values (i.e., RfDs and CSFs) available for risk quantitation. This is the case for lead. The following section provides a discussion of how lead health effects were quantified for this assessment.

In addition, there are some chemicals with different toxicity values associated with the medium in which they are detected. For example, the oral RfD for cadmium differ when found in food or water. Consequently, the oral RfD associated with food were applied for assessing soil exposure, and the oral RfD associated with water were used accordingly.

6.4.3 Lead

Lead was identified as a COPC in groundwater at Site 86. Currently, health-based criteria are not available for evaluating either the noncarcinogenic or carcinogenic effects of lead exposure. The USEPA has not developed health-based criteria because a threshold level for many noncancer health effects has not been identified in infants and younger children (i.e., the most sensitive populations). Consequently, risk from lead exposure was not calculated for the site.

To evaluate lead at waste sites, the USEPA had developed a lead uptake/biokinetic (UBK) model. This model utilizes site-specific exposure parameters to estimate blood lead levels in infants and young children. The USEPA considers remediation necessary if a 5 percent probability or greater exists that the predicted child blood level will exceed 10 µg/dl as a result of contact with lead-containing media at the site.

There are several criteria available for lead level comparisons in the form of standards, criteria and/or TBCs. These standards/criteria/TBCs include federal and state MCLs and AWQC. In

addition, there is an Office of Solid Waste and Emergency Response (OSWER) directive for lead in soil. This concentration is 400 mg/kg. At Site 86, lead in groundwater at the site exceeded the federal action level. Consequently, the lead UBK model was utilized to evaluate the risk associated with exposure to lead-containing groundwater at Site 86.

6.4.4 Dermal Adjustment of Toxicity Factors

Because there are few toxicity reference values for dermal exposure, oral values are frequently used to assess risk from dermal exposure. Most RfDs and some slope factors are expressed as the amount of substance administered per unit time and unit body weight, while exposure estimates for the dermal route are expressed as absorbed dose. Consequently, it may be necessary to adjust an oral toxicity value from an administered dose to an absorbed dose.

Region IV provides absorption efficiency values for each class of chemicals. They are as follows:

VOCs	=	0.80
SVOCs	=	0.50
Inorganics	=	0.20
Pesticides/PCBs	=	0.50

An adjusted oral RfD is the product of the absorption efficiency and the oral toxicity reference value. The adjusted oral CSF is the ratio of the oral toxicity value and the absorption efficiency. Table 7-7 presents a summary of the dermally-adjusted toxicity values used in this BRA.

6.5 Risk Characterization

This section presents and discusses the estimated incremental lifetime cancer risks (ICRs) and hazard indices (HIs) for identified potential receptor groups which could be exposed to COPCs via the exposure pathways presented in Section 6.3.2.

These quantitative risk calculations for potentially carcinogenic compounds estimate ICRs levels for an individual in a specified population. This unit risk refers to the cancer risk that is over and above the background cancer risk in unexposed individuals. For example, an ICR of 1×10^{-6} indicates that, for a lifetime exposure, one additional case of cancer may occur per one million exposed individuals.

The ICR to individuals was estimated from the following relationship:

$$ICR = \sum_{i=1}^n CDI_i \times CSF_i$$

where CDI_i is the chronic daily intake (mg/kg/day) for compound i and CSF_i is the cancer slope in $(\text{mg/kg/day})^{-1}$ for contaminant i . The CSF is defined in most instances as an upper 95th percentile confidence limit of the probability of a carcinogenic response based on experimental animal data, and the CDI is defined as the exposure expressed as a mass of a substance contracted per unit body weight per unit time, averaged over a period of time (i.e., six years to a lifetime). The above equation was derived assuming that cancer is a non-threshold process and that the potential excess risk level is proportional to the cumulative intake over a lifetime.

In contrast to the above approach for potentially carcinogenic effects, quantitative risk calculations for noncarcinogenic compounds assume that a threshold toxicological effect exists. Therefore, the potential for noncarcinogenic effects is calculated by comparing CDIs with threshold levels (reference doses).

Noncarcinogenic effects were estimated by calculating the hazard index (HI) which is defined as:

$$HI = HQ_1 + HQ_2 + \dots HQ_n \text{ or}$$

$$HI = \sum_{i=1}^n HQ_i$$

$$\text{where } HQ_i = CDI_i / RfD_i$$

HQ_i is the hazard quotient for contaminant i , CDI_i is the chronic daily intake (mg/kg/day) of contaminant i , and RfD_i is the reference dose (mg/kg/day) of the contaminant i over a prolonged period of exposure.

6.5.1 Human Health Risks

The following paragraphs present the quantitative results of the human health evaluation for each medium and area of concern at Site 86.

Estimated ICRs were compared to the target risk range of 1×10^{-6} to 1×10^{-4} . A value of 1.0 was used for examination of the HI. The HI was calculated by comparing estimated CDIs with threshold levels below which, noncarcinogenic health effects are not expected to occur. Any HI equal to or exceeding 1.0 suggested that noncarcinogenic health effects were possible. If the HI was less than 1.0, then systemic human health effects were considered unlikely. Tables 6-8 through 6-13 present these risk results.

6.5.1.1 Current Military Personnel

The current military receptor was evaluated for potential noncarcinogenic and carcinogenic risk from exposure to the surface soil. The noncarcinogenic (i.e., $HI=0.035$) and carcinogenic risk (i.e., $ICR=9.3 \times 10^{-7}$) from exposure to surface soil fell below the acceptable risk levels (i.e., $HI < 1$ and $1 \times 10^{-6} < ICR < 1 \times 10^{-4}$). These results are presented in Table 6-8.

6.5.1.2 Current Trespasser Child

In the current scenario, a trespasser receptor was evaluated for potential risk from exposure to site surface soils. The potential noncarcinogenic and carcinogenic risks from exposure to the surface soil (i.e., $HI=0.076$ and $ICR=2.6 \times 10^{-6}$) were within acceptable risk levels (i.e., $HI < 1$ and $1 \times 10^{-6} < ICR < 1 \times 10^{-4}$). The results are summarized in Table 6-9.

6.5.1.3 Future Residential Child

The child receptor was evaluated for potential risk from exposure to subsurface soil and groundwater in the future scenario. In subsurface soil, the potential noncarcinogenic and carcinogenic risks from

exposure to the subsurface soil (i.e., $HI=0.76$ and $ICR=3.5 \times 10^{-6}$) were within acceptable risk levels (i.e., $HI < 1$ and $1 \times 10^{-6} < ICR < 1 \times 10^{-4}$). The results are summarized in Table 6-10.

In groundwater, there is a potential noncarcinogenic risk from ingestion. The noncarcinogenic risk level was 18. This value exceeded the acceptable risk level of one for noncarcinogenic risks. Antimony, arsenic, and iron in groundwater contributed to this risk. Arsenic exhibits both carcinogenic and noncarcinogenic effects. Antimony and iron are noncarcinogens. The risk results are presented in Table 6-10.

6.5.1.4 Current Trespasser Adult

In the current scenario, an adult trespasser was evaluated for potential risk from exposure to site surface soils (i.e., $HI < 0.01$ and $ICR=9.2 \times 10^{-7}$). The potential noncarcinogenic and carcinogenic risks from exposure to this medium were within acceptable risk levels (i.e., $HI < 1$ and $1 \times 10^{-6} < ICR < 1 \times 10^{-4}$). These results are provided in Table 6-11.

6.5.1.5 Future Residential Adult

The adult receptor was evaluated for potential risk from exposure to subsurface soil and groundwater in the future scenario. In subsurface soil (i.e., $HI=0.1$ and $ICR=2.3 \times 10^{-6}$), the potential noncarcinogenic and carcinogenic risks from exposure to these media were within acceptable levels (i.e., $HI < 1$ and $1 \times 10^{-6} < ICR < 1 \times 10^{-4}$).

In groundwater, the potential noncarcinogenic and carcinogenic risks from ingestion do not fall within acceptable risk levels. The potential noncarcinogenic risk from groundwater ingestion was 8.0. The total potential carcinogenic risk from groundwater was 1.3×10^{-4} . These risk values exceeded the acceptable risk levels of one for noncarcinogenic risks and 1×10^{-4} for carcinogenic risks. Antimony, arsenic, and iron contributed to the risks. Arsenic exhibits both carcinogenic and noncarcinogenic effects. Antimony and iron are noncarcinogens. Table 6-12 is a summary of these results.

6.5.1.7 Future Construction Worker

The construction worker was evaluated for potential noncarcinogenic and carcinogenic risk from exposure to the surface and subsurface soil in the future case. Both noncarcinogenic (i.e., $HI=0.15$) and carcinogenic risks (i.e., $CR=3.5 \times 10^{-7}$) from exposure to the soil for this receptor fell within the acceptable risk levels. Table 6-13 presents these results.

6.6 Lead UBK Model Results

The USEPA lead UBK model was used to determine if exposure to site media would result in unacceptable blood lead levels in younger children upon exposure to the groundwater at Site 86. Blood lead levels are considered unacceptable when a greater than 5 percent probability exists that the blood lead levels will exceed $10 \mu\text{g}/\text{dl}$.

The maximum concentrations of lead found in the groundwater were used in the model. The remaining model parameters used were the default factors supplied in the model. The maximum concentration in groundwater resulted in an 8.79 percent probability of the blood lead levels

exceeding 10 µg/dl, which is not within acceptable levels. Figures 6-2 and 6-3 illustrate these results.

6.7 Sources of Uncertainty

Uncertainties may be encountered throughout the BRA process. This section discusses the sources of uncertainty involved with the following:

- Analytical data
- Exposure Assessment
- Toxicity Assessment
- Compounds Not Qualitatively Evaluated

In addition, the USEPA stresses the importance of recognizing the unique characteristics and circumstances of each facility and the need to formulate site-specific responses. However, many of the assumptions presented in this document were derived from USEPA guidance, which is designed to provide a conservative approach and cover a broad variety of cases. As such, the generic application of such assumptions to a site in the RME case scenario may work against the objective of formulating a site-specific response to a constituent presence (i.e., it is possible that the site risks may be overestimated).

The following sections provide a discussion of the sources of uncertainty associated with this BRA and the effects on total site risk. Table 6-14 is a summary of these sources.

6.7.1 Analytical Data Uncertainty

The development of a BRA depends on the reliability of and uncertainties with the analytical data available to the risk assessor. Analytical data are limited by the precision and accuracy of the analytical method of analysis. In addition, the statistical methods used to compile and analyze the data (mean concentration, standard deviation, and detection frequencies) are subject to the uncertainty in the ability to acquire data.

Data validation serves to reduce some of the inherent uncertainty associated with the analytical data by establishing the usability of the data to the risk assessor who may or may not choose to include the data point in the estimation of risk. Data qualified as "J" (estimated) were retained for the estimation of risk at OU No.6. Data can be qualified as estimated for many reasons including a slight exceedance of holding times, high or low surrogate recovery, or intra sample variability. Organic data qualified "B" (detected in blank) were not used in the estimation of risk because these levels were attributed to blank contamination. Data qualified with an "R" (rejected) were not used in the estimation of risk due to the unusable nature of the data. Section 4.1 presents a brief discussion of the data quality. Due to the comprehensive sampling and analytical program at OU No. 6, the loss of some data points qualified "B" or "R" did not significantly increase the uncertainty in the estimation of risk.

6.7.2 Exposure Assessment Uncertainty

In performing exposure assessments, uncertainties can arise from two main sources. First, the chemical concentration to which a receptor may be exposed must be estimated for every medium

of interest. Second, uncertainties can arise in the estimation of contaminant intakes resulting from contact by a receptor with a particular medium.

Estimating the contaminant concentration in a given medium to which a human receptor could potentially be exposed can be as simple as deriving the 95th percent upper confidence limit of the mean for a data set. More complex methods of deriving the contaminant concentration are necessary when exposure to COPCs in a given medium occurs subsequent to release from another medium, or when analytical data are not available to characterize the release. In this case, modeling is usually employed to estimate the potential human exposure.

The potential inhalation of fugitive dusts from affected soils was estimated in the BRA using USEPA's Rapid Assessment of Exposure to Particulate Emissions from Surface Contaminated Sites (Cowherd et al. 1985). The Cowherd model employs the use of a default PEF for wind erosion based on a one-half acre source area and 50 percent vegetative cover. Modeling results for fugitive dust emission exposure suggested that the potential risk associated with this pathway was not significant.

Groundwater samples were analyzed for total (unfiltered) and dissolved (filtered) inorganic contaminants. These samples were obtained from wells which were constructed using USEPA Region IV monitoring well design specifications. Groundwater taken from monitoring wells cannot be considered representative of potable groundwater or groundwater which is obtained from a domestic well "at the tap". The use of total inorganic analytical results overestimates the potential human health risks associated with potable use scenarios. However, for the sake of conservatism, total organic results were used to estimate the potential intake associated with groundwater use.

As stated previously, both the shallow and deep groundwater analytical results were combined and evaluated as single data set for the risk evaluation. It is important to note that the shallow groundwater is not currently used for potable purposes at the site. In addition, it is highly unlikely that this groundwater will be used similarly in the future. However, because it was determined (see Section 2.0 of this report) that the shallow and deep groundwater systems are interconnected, the data were combined and evaluated as a single set for the risk assessment. Use of this combined data set lends a certain degree of uncertainty to the risks calculated for groundwater exposure.

To estimate an intake, certain assumptions must be made about exposure events, exposure durations, and the corresponding assimilation of contaminants by the receptor. Exposure factors, have been generated by the scientific community and have undergone review by the USEPA. Regardless of the validity of these exposure factors, they have been derived from a range of values generated by studies of limited number of individuals. In all instances, values used in the risk assessment, scientific judgments, and conservative assumptions agree with those of the USEPA. Conservative assumptions designed not to underestimate daily intakes were employed throughout the BRA and should error conservatively, thus adequately protecting human health and allowing the establishment of reasonable clean-up goals.

6.7.3 Sampling Strategy Uncertainty

Soil represents a medium of direct contact exposure and often is the main source of contaminants released into other media. The soil sampling depth should be applicable for the exposure pathways and contaminant transport routes of concern and should be chosen purposely within that depth interval. If a depth interval is chosen purposely, a random sample procedure to select a sampling

point may be established. The assessment of surface exposure at the site is certain based on collection of samples from the shallowest depth, zero to one foot. Subsurface soil samples are important, however, if soil disturbance is likely or leaching of chemicals to groundwater is of concern.

The surface soil samples at all sites were obtained directly or very near the suspected disposal areas. Therefore, these areas would be considered areas of very high concentration which would have a significant impact on exposures.

In the future exposure scenarios, subsurface soil exposure was evaluated. It was assumed that the subsurface soil would be excavated and used as surface grading, landscaping, etc., in the foreseeable future. It is important to note that many of these subsurface soil samples were collected at depths ranging from 1 foot to possibly up to 90 feet, depending on the depth of the well from which the soil boring was collected. It may be unrealistic to assume that excavation could occur at such depths. It follows that exposure to contaminants in soil at these depths would be unlikely for future receptors. However, for the BRA, the subsurface soil analytical results were not segregated by depth, but were evaluated as a single data set. Consequently, levels found at all depths were evaluated for potential risk to human health. The use of the entire subsurface soil data set may add to the conservative nature of the approach used to assess risk for this site.

6.7.4 Toxicity Assessment Uncertainty

In making quantitative estimates of the toxicity of varying doses of a compound to human receptors, uncertainties arise from two sources. First, data on human exposure and the subsequent effects are usually insufficient, if they are available at all. Human exposure data usually lack adequate concentration estimations and suffer from inherent temporal variability. Therefore, animal studies are often used; and, therefore, new uncertainties arise from the process of extrapolating animal results to humans. Second, to obtain observable effects with a manageable number of experimental animals, high doses of a compound are used over a relatively short time period. In this situation, a high dose means that experimental animal exposures are much greater than human environmental exposures. Therefore, when applying the results of the animal experiment to humans; the effects at the high doses must be extrapolated to approximate effects at lower doses.

In extrapolating effects from animals to humans and high doses to low doses, scientific judgment and conservative assumptions are employed. In selecting animal studies for use in dose-response calculations, the following factors are considered:

- Studies are preferred where the animal closely mimics human pharmacokinetics
- Studies are preferred where dose intake most closely mimics the intake route and duration for humans
- Studies are preferred which demonstrate the most sensitive response to the compound in question

For compounds believed to cause threshold effects (i.e., noncarcinogens), safety factors are employed in the extrapolation of effects from animals to humans and from high to low doses.

Conservatism is also introduced through the use of experimentally-derived oral absorption efficiencies to adjust oral toxicity criteria (i.e., CSFs and RfDs), derived during studies based on administered dosages, for the estimation of dermal absorption. Equating the absorption efficiency of the bi-phasic dermal barrier to that of the mono-phasic gastrointestinal lining and then applying it to oral toxicity criteria in a dermal risk assessment scenario tends to generally overestimate the potential risk to human health by no more than an order of magnitude.

The use of conservative assumptions results in quantitative indices of toxicity that are not expected to underestimate potential toxic effects, but may overestimate these effects by an order of magnitude or more.

6.8 Conclusions of the BRA for Site 86

The BRA highlights the media of interest from the human health standpoint at Site 86 by identifying areas with risk values greater than acceptable levels. Current and future potential receptors at the site included current military personnel, current trespassers (i.e., children and adults), future residents (i.e., children and adults), and future construction workers. The total risk from the site for these receptors was estimated by logically summing the multiple pathways likely to affect the receptor during a given activity. Exposure to surface soil was assessed for the current receptors. Subsurface soil and groundwater exposure were evaluated for the future receptors.

6.8.1 Current Scenario

In the current case, the following receptors were assessed: military personnel and adult and child trespassers. Receptor exposure to surface soil was evaluated. The calculated risk values for these receptors were within acceptable risk levels.

6.8.2 Future Scenario

In the future case, child and adult residents were assessed for potential exposure to groundwater and subsurface soil. A construction worker was evaluated for soil exposure. The potential risks calculated for the construction worker were within acceptable risk levels.

The total noncarcinogenic risk and carcinogenic risk for the adult resident exceeded acceptable risk levels of one for noncarcinogenic effects and 1×10^{-4} for carcinogenic effects. These values were 8.1 and 1.3×10^{-4} , respectively. The total noncarcinogenic risk for the child resident, 20, was also greater than the acceptable risk level of one. In both cases, groundwater ingestion was the main exposure route contributing to these unacceptable risks. In terms of lead effects, exposure to the maximum concentration of lead in the groundwater for a child receptor indicates the potential for adverse health effects. The maximum levels of iron and lead and the lognormal 95% UCL values of arsenic and antimony in groundwater contributed to these risks. Table 6-15 is a summary of these concentrations.

As stated previously, groundwater is not currently used as a potable source at the site. Future residential development of the site is unlikely given the industrial setting of site and its proximity to the flight line. Based on this information, the future groundwater exposure scenario evaluated in this BRA is unlikely to occur.

Although antimony was found infrequently in groundwater, it was detected at levels greater than both risk-based screening levels and federal and state criteria. Arsenic was detected frequently in the site groundwater at levels greater than the risk-based screening level. However, these same levels were below both federal and state safe drinking water criteria (i.e., MCLs). Lead was only found once in the groundwater, but at a level that exceeded the federal drinking water action level.

As explained in Section 4.0 of this report, groundwater in the MCB, Camp Lejeune area is naturally rich in iron. There is no record of any historical use of iron at Site 86. Positive detections of both iron and manganese were distributed throughout the site, indicative of natural site conditions rather than disposal activities. It is suggested that total metal concentrations in groundwater are due more to geologic conditions (i.e., naturally occurring concentrations and unconsolidated soils) and sample acquisition methods than to mobile metal concentrations in the surficial aquifer. Consequently, it is assumed that iron is a naturally-occurring inorganic in groundwater, and its presence is not attributable to site operations.

Iron is an essential nutrient. The toxicity values associated with exposure to this metal are based on provisional studies, which have not been verified by USEPA. In fact, if iron were removed from the evaluation of risk from groundwater ingestion, the noncarcinogenic risk for the child would decrease from 18 to 3 and, for the adult, from 7.8 to 1.6. As a result, the potential human health risk from exposure to these metals in groundwater may be a conservative and unrealistic estimate.

6.9 References

Cowherd et al., 1985. Cowherd, C. et al. Rapid Assessment of Exposure to Particulate Emissions from Surface Contamination. Prepared for EPA Office of Health and Environmental Assessment. EPA/600/8-85/002.

Foster, 1986. Foster, S.A. and P.C. Chrostowski. "Integrated Household Exposure Model for Use of Tap Water Contaminated with Volatile Organic Chemicals." Presented at the 79th Annual Meeting of the Air Pollution Control Association, Minneapolis, Minnesota. June 22-27, 1986.

USEPA, 1989. U.S. Environmental Protection Agency. Risk Assessment Guidance for Superfund Volume I. Human Health Evaluation Manual (Part A) Interim Final. Office of Solid Waste and Emergency Response. Washington, D.C. EPA/540/1-89-002. December 1989.

USEPA, 1989a. U.S. Environmental Protection Agency. Exposure Factors Handbook. July 1989.

USEPA, 1990. U.S. Protection Agency. National Oil and Hazardous Substances Pollution Contingency Plan. 55FR8665. Office of Emergency and Remedial Response. Washington, D.C. March 1990.

USEPA, 1991. U.S. Environmental Protection Agency. Risk Assessment Guidance for Superfund Volume I. Human Health Evaluation Manual Supplemental Guidance. "Standard Default Exposure Factors" Interim Final. Office of Solid Waste and Emergency Response. Washington, D.C. OSWER Directive 9285.6-03. March 25, 1991.

USEPA, 1992. U.S. Environmental Protection Agency. Dermal Exposure Assessment: Principles and Applications. Interim Report. Office of Health and Environmental Assessment. Washington, D.C. EPA/600/8-91/011B. January 1992.

USEPA, 1992a. U.S. Environmental Protection Agency. New Interim Region IV Guidance for Toxicity Equivalency Factor (TEF) Methodology. Region IV Water Management Division.

USEPA, 1992b. U.S. Environmental Protection Agency. Supplemental Guidance to RAGS: Calculating the Concentration Term. Office of Solid Waste and Emergency Response. Washington, D.C., Publication 9285.7-081. May 1992.

USEPA, 1992c. USEPA Region IV Supplemental Risk Guidance. February 11, 1992.

USEPA, 1993. U.S. Environmental Protection Agency. Region IV Waste Management Division Screening Values for Hazardous Waste Sites. Region IV, Atlanta Georgia. January 1993.

USEPA. 1995. U.S. Environmental Protection Agency. Health Effects Assessment Summary Tables Annual FY-1995. Office of Solid Waste and Emergency Response. Washington, D.C. EPA/540/R-95/036 PB95-921199. May 1995.

USEPA, 1995a. U.S. Environmental Protection Agency. Integrated Risk Information System (IRIS). Environmental Criteria and Assessment Office, Cincinnati, Ohio.

USEPA, 1995b. U.S. Environmental Protection Agency. Region III Risk-Based Concentration Table. Philadelphia, Pennsylvania. October, 1995.

USEPA, 1995c. U. S. Environmental Protection Agency. Phone conversation with Janine Dinan. Washington, D.C. November 17, 1995.

WAR, 1983. Water and Air Research, Inc. Initial Assessment Study of Marine Corps Base Camp Lejeune, North Carolina. Prepared for Naval Energy and Environmental Support Activity. 1983.

SECTION 6.0 TABLES

TABLE 6-1

**CONTAMINANTS OF POTENTIAL CONCERN
IN SURFACE SOIL
SITE 86, ABOVEGROUND STORAGE TANK AREA
REMEDIAL INVESTIGATION CTO-0303
MCAS, NEW RIVER, NORTH CAROLINA**

Contaminant	Minimum	Maximum	Lognormal UCL	Location of Maximum	Frequency	Frequency Percent	Site Background	Exceedance Frequency	Residential Soil RBC	Exceedance Frequency
Volatiles (µg/kg)										
Acetone	28	28	11.20	86-AST-SB06-00	1/18	6%	NA	NA	780,000	0/1
Toluene	25	25	7.79	86-GW18DW-00	1/18	6%	NA	NA	1,600,000	0/1
Xylene (total)	5	5	6.00	86-AST-SB02-00	1/18	6%	NA	NA	16,000,000	0/1
Semivolatiles (µg/kg)										
Naphthalene	85	85	200.28	86-AST-SB11-00	1/18	6%	NA	NA	310,000	0/1
2-Methylnaphthalene	80	80	201.37	86-AST-SB11-00	1/18	6%	NA	NA	310,000	0/1
Acenaphthene	50	580	247.99	86-AST-SB11-00	4/18	22%	NA	NA	470,000	0/4
Dibenzofuran	220	220	196.49	86-AST-SB11-00	1/18	6%	NA	NA	31,000	0/1
Fluorene	43	440	240.43	86-AST-SB11-00	3/18	17%	NA	NA	310,000	0/3
Phenanthrene	64	2,700	571.71	86-AST-SB11-00	8/18	44%	NA	NA	230,000	0/8
Anthracene	43	790	278.29	86-AST-SB11-00	5/18	28%	NA	NA	2,300,000	0/5
Carbazole	39	480	253.32	86-AST-SB11-00	5/18	28%	NA	NA	32,000	0/5
Fluoranthene	39	3,500	1,032.94	86-AST-SB11-00	9/18	50%	NA	NA	310,000	0/9
Pyrene	110	3,100	732.98	86-AST-SB11-00	10/18	56%	NA	NA	230,000	0/10
Butylbenzylphthalate	49	380	250.43	86-AST-SB03-00	4/18	22%	NA	NA	1,600,000	0/4
Benzo(a)anthracene	70	2,100	506.09	86-AST-SB11-00	10/18	56%	NA	NA	880	2/10
Chrysene	86	2,100	516.61	86-AST-SB11-00	9/18	50%	NA	NA	88,000	0/9
Bis(2-ethylhexyl)phthalate	47	86	207.21	86-GW18DW-00	2/18	11%	NA	NA	46,000	0/2
Benzo(b)fluoranthene	110	2,300	559.48	86-AST-SB11-00	8/18	44%	NA	NA	880	2/8
Benzo(k)fluoranthene	57	950	329.27	86-AST-SB11-00	8/18	44%	NA	NA	8,800	0/8
Benzo(a)pyrene	48	1,800	527.25	86-AST-SB11-00	10/18	56%	NA	NA	88	9/10
Indeno(1,2,3-cd)pyrene	67	1,100	353.43	86-AST-SB11-00	7/18	39%	NA	NA	880	1/7
Dibenzo(a,h)anthracene	37	290	228.11	86-AST-SB11-00	4/18	22%	NA	NA	88	3/4
Benzo(g,h,i)perylene	57	590	266.08	86-GW19DW-00	7/18	39%	NA	NA	230,000	0/7

TABLE 6-1 (Continued)

CONTAMINANTS OF POTENTIAL CONCERN
 IN SURFACE SOIL
 OPERABLE UNIT NO. 6 (SITE 86)
 REMEDIAL INVESTIGATION CTO-0303
 MCAS, NEW RIVER, NORTH CAROLINA

Contaminant	Minimum	Maximum	Lognormal UCL	Location of Maximum	Frequency	Frequency Percent	Site Background	Exceedance Frequency	Residential Soil RBC	Exceedance Frequency
Pesticides/PCBs (µg/kg)										
Aldrin	2	2	1.19	86-GW18DW-00	1/11	9%	NA	NA	38	0/1
Heptachlor epoxide	5.2	5.2	1.86	86-GW19DW-00	1/11	9%	NA	NA	70	0/1
Dieldrin	4.8	44	70.91	86-AST-SB01-00	10/11	91%	NA	NA	40	1/10
4,4'-DDE	4.9	38	29.39	86-GW19DW-00	11/11	100%	NA	NA	1,900	0/11
4,4'-DDD	5.2	9.6	9.14	86-AST-SB08-00	5/11	45%	NA	NA	2,700	0/5
4,4'-DDT	4.3	27	25.29	86-AST-SB08-00	10/11	91%	NA	NA	1,900	0/10
Inorganics (mg/kg)										
Aluminum	4,590	6,660	6,136.52	86-AST-SB08-00	11/11	100%	5,940.6	5/11	7800	0/5
Arsenic	0.53	1.8	1.68	86-AST-SB08-00	9/11	82%	1.31	2/9	2.3/0.43	9/9
Barium	7.7	133	57.36	86-AST-SB04-00	11/11	100%	17.36	3/11	550	0/11
Cadmium	0.48	1.1	0.71	86-GW18DW-00	5/11	45%	0.688	2/5	3.9	0/5
Calcium	1,380	19,900	10,269.83	86-AST-SB01-00	11/11	100%	1,396.8	10/11	NA	NA
Chromium	5.1	10.1	9.08	86-AST-SB08-00	11/11	100%	6.69	8/11	39	0/11
Cobalt	0.48	0.48	0.38	86-GW19DW-00	1/11	9%	1.9	0/1	470	0/1
Copper	1.1	53.4	37.39	86-GW18DW-00	10/11	91%	7.2	3/10	310	0/10
Iron	1,670	5,580	4,341.75	86-GW18DW-00	11/11	100%	3,755.06	5/11	2,300	6/11
Lead	12.4	43.1	35.72	86-AST-SB03-00	11/11	100%	23.75	5/11	400	0/11
Magnesium	157	835	541.26	86-AST-SB06-00	11/11	100%	205.75	9/11	NA	NA
Manganese	5.5	21.7	15.71	86-GW19DW-00	11/11	100%	18.5	2/11	1,100 ¹	0/11
Mercury	0.16	0.16	0.08	86-GW19DW-00	1/11	9%	0.094	1/1	2.3	0/1
Nickel	1.3	22.3	23.47	86-GW19DW-00	8/11	73%	3.43	7/8	160	0/8
Potassium	139	340	267.50	86-AST-SB07-00	11/11	100%	199.6	8/11	NA	NA
Selenium	0.29	0.69	0.41	86-GW18DW-00	5/11	45%	0.746	0/5	39	0/5

TABLE 6-1 (Continued)

CONTAMINANTS OF POTENTIAL CONCERN
 IN SURFACE SOIL
 OPERABLE UNIT NO. 6 (SITE 86)
 REMEDIAL INVESTIGATION CTO-0303
 MCAS, NEW RIVER, NORTH CAROLINA

Contaminant	Minimum	Maximum	Lognormal UCL	Location of Maximum	Frequency	Frequency Percent	Site Background	Exceedance Frequency	Residential Soil RBC	Exceedance Frequency
Inorganics (mg/kg) (Continued)										
Sodium	40.6	42.8	51.08	86-AST-SB05-00	5/11	45%	59.3	0/5	NA	NA
Vanadium	7.9	92.7	56.30	86-GW19DW-00	11/11	100%	11.6	7/11	55	2/11
Zinc	5.4	39.9	33.60	86-GW18DW-00	11/11	100%	13.9	6/11	2,300	0/11

Notes:

COPCs indicated by shaded areas.

¹ The residential soil RBC for manganese is based on an oral RfD of 0.14 mg/kg/day and not 0.005 mg/kg/day, as listed in the Region III RBC table (October, 1995). The latter toxicity value has been withdrawn from IRIS.

TABLE 6-2

**CONTAMINANTS OF POTENTIAL CONCERN
IN SUBSURFACE SOIL
SITE 86, ABOVEGROUND STORAGE TANK AREA
REMEDIAL INVESTIGATION CTO-0303
MCAS, NEW RIVER, NORTH CAROLINA**

Contaminant	Minimum	Maximum	Lognormal UCL	Location of Maximum	Frequency	Frequency Percent	Site Background	Exceedance Frequency	Residential Soil RBC	Exceedance Frequency
Volatiles (µg/kg)										
Acetone	40	250	86.64	86-GW17IW-01	8/23	35%	NA	NA	780,000	0/8
Carbon Disulfide	3	3	6.61	86-WA-SB01-02	1/23	4%	NA	NA	780,000	0/1
2-Butanone	8	8	6.68	86-AST-SB05-03	1/23	4%	NA	NA	4,700,000	0/1
Toluene	250	250	14.63	86-GW18DW-02	1/23	4%	NA	NA	1,600,000	0/1
Xylene (total)	5	5	6.53	86-AST-SB07-03	2/23	9%	NA	NA	16,000,000	0/2
Semivolatiles (µg/kg)										
Fluoranthene	62	62	230.16	86-GW19DW-02	1/23	4%	NA	NA	310,000	0/1
Pyrene	57	57	231.90	86-GW19DW-02	1/23	4%	NA	NA	230,000	0/1
Butylbenzylphthalate	73	300	224.89	86-AST-SB11-03	4/23	17%	NA	NA	1,600,000	0/4
Chrysene	42	140	238.38	86-AST-SB04-02	2/23	9%	NA	NA	88,000	0/2
Bis(2-ethylhexyl)phthalate	45	970	371.16	86-AST-SB05-05	5/23	22%	NA	NA	46,000	0/5
Benzo(b)fluoranthene	43	43	239.66	86-GW19DW-02	1/23	4%	NA	NA	880	0/1
Pesticides (µg/kg)										
4,4'-DDE	1.5	20	5.33	86-AST-SB04-02	5/16	31%	NA	NA	1,900	0/5
4,4'-DDD	3.2	36	7.73	86-GW17IW-01	5/16	31%	NA	NA	2,700	0/5
4,4'-DDT	1.5	1.5	2.14	86-AST-SB04-02	1/16	6%	NA	NA	1,900	0/1
Inorganics (mg/kg)										
Aluminum	2,140	24,900	16,587.65	86-AST-SB06-04	16/16	100%	7375.3	12/16	7,800	12/16
Antimony	2.2	2.2	2.08	86-GW17IW-02	1/12	8%	6.4	0/1	3.1	0/1
Arsenic	0.27	2.4	1.99	86-AST-SB07-03	13/16	81%	1.968	2/13	2.3/0.43	12/13
Barium	3.7	32.8	24.07	86-AST-SB06-04	16/16	100%	14.2	13/16	550	0/16
Calcium	51.9	10,300	7,224.85	86-AST-SB04-02	16/16	100%	391.51	12/16	NA	NA
Chromium	2.4	34.4	21.03	86-AST-SB06-04	16/16	100%	12.6	9/16	39	0/16
Cobalt	0.39	1.2	0.60	86-AST-SB06-04	5/16	31%	1.5	0/5	470	0/5
Copper	0.55	7.1	4.22	86-AST-SB04-02	14/16	88%	2.4	5/14	310	0/14

TABLE 6-2 (Continued)

CONTAMINANTS OF POTENTIAL CONCERN
IN SUBSURFACE SOIL
OPERABLE UNIT NO. 6 (SITE 86)
REMEDIAL INVESTIGATION CTO-0303
MCAS, NEW RIVER, NORTH CAROLINA

Contaminant	Minimum	Maximum	Lognormal UCL	Location of Maximum	Frequency	Frequency Percent	Site Background	Exceedance Frequency	Residential Soil RBC	Exceedance Frequency
Inorganics (mg/kg) (Cont.)										
Iron	938	10,900	9,974.29	86-AST-SB05-03	16/16	100%	7252.08	7/16	2,300	13/16
Lead	3	16.6	12.68	86-AST-SB06-04	16/16	100%	8.3	11/16	400	0/16
Magnesium	62.6	925	623.88	86-AST-SB06-04	16/16	100%	260.7	12/16	NA	NA
Manganese	2.1	12.3	9.96	86-AST-SB06-04	16/16	100%	7.9	8/16	1,100 ¹	0/16
Nickel	0.95	28.2	7.42	86-AST-SB05-05	12/16	75%	3.7	4/12	160	0/12
Potassium	48	1120	655.18	86-AST-SB06-04	16/16	100%	347.2	7/16	NA	0/16
Selenium	0.35	0.59	0.28	86-GW18DW-02	3/16	19%	0.8	0/3	39	0/3
Sodium	29.5	147	129.99	86-AST-SB02-02	13/16	81%	52.7	9/13	NA	0/13
Vanadium	3.1	32.7	28.02	86-AST-SB03-04	16/16	100%	13.5	12/16	55	0/16
Zinc	1.3	7.9	5.38	86-AST-SB06-04	15/16	94%	6.7	2/15	2,300	0/15

Notes:

COPCs indicated by shaded areas.

¹ The residential soil RBC for manganese is based on an oral RfD of 0.14 mg/kg/day and not 0.005 mg/kg/day, as listed in the Region III RBC table (October, 1995). The latter toxicity value has been withdrawn from IRIS.

TABLE 6-3

**CONTAMINANTS OF POTENTIAL CONCERN
IN GROUNDWATER
SITE 86, ABOVEGROUND STORAGE TANK AREA
REMEDIAL INVESTIGATION CTO-0303
MCAS, NEW RIVER, NORTH CAROLINA**

Contaminant	Minimum	Maximum	Lognormal UCL	Location of Maximum	Frequency	Frequency Percent	Tap Water RBC	Exceedance Frequency	Federal MCL	Exceedance Frequency	NCWQS	Exceedance Frequency
Volatiles (µg/L)												
1,1-Dichloroethane	10	14	5.60	86-GW10IW-01	2/41	5%	81	0/2	NA	NA	700	0/2
1,2-Dichloroethene (total)	3	140	13.65	86-GW15IW-02	14/41	34%	5.5	10/14	70	2/14	NA	NA
Chloroform	2	2	5.14	86-GW10IW-02	1/41	2%	0.15	1/1	100	0/1	0.19	1/1
Trichloroethene	2	400	17.43	86-GW20IW-02	13/41	32%	1.6	13/13	5	8/13	NA	NA
Benzene	2	8	5.28	86-GW15IW-01	7/41	17%	0.36	7/7	5	2/7	1	7/7
Tetrachloroethene	1	77	8.67	86-GW10IW-01	4/41	10%	1.1	3/4	5	3/4	0.7	4/4
Semivolatiles (µg/L)												
Naphthalene	6	6	5.10	86-GW10IW-01	1/23	4%	150	0/1	NA	NA	21	0/1
Dibenzofuran	1	1	5.63	86-GW07-01	1/23	4%	15	0/1	NA	NA	NA	NA
Fluorene	2	2	5.24	86-GW07-01	1/23	4%	150	0/1	NA	NA	280	0/1
Di-n-butylphthalate	23	23	6.37	86-GW17IW-01	1/23	4%	370	0/1	NA	NA	700	0/1
Inorganics (µg/L)												
Aluminum	187	815	118.31	86-GW03-01	2/26	8%	3,700	0/2	NA	NA	NA	NA
Antimony	23.6	23.6	11.44	86-GW16DW-01	1/26	4%	1.5	1/1	6	1/1	NA	NA
Arsenic	2.5	38.8	6.55	86-GW01-01	7/26	27%	1.1/0.045	7/7	50	0/7	50	0/7
Barium	8.6	44.5	26.85	86-GW09-01	12/26	46%	260	0/12	2000	0/12	2000	0/12
Calcium	937	145,000	1.76E+05	86-GW08IW-01	26/26	100%	NA	NA	NA	NA	NA	NA
Iron	5.1	68,300	3.0E+05	86-GW07-01	23/26	88%	1,100	14/23	NA	NA	300	19/23
Lead	28.3	28.3	1.41	86-GW06IW-01	1/26	4%	NA	NA	15	1/1	15	1/1
Magnesium	762	17,300	4648.54	86-GW11-01	26/26	100%	NA	NA	NA	NA	NA	NA
Manganese	3.8	416	397.43	86-GW17IW-01	22/26	85%	510 ¹	0/22	NA	NA	50	15/22
Potassium	717	19,100	6,709.05	86-GW11-01	25/26	96%	NA	NA	NA	NA	NA	NA
Selenium	1.6	2	0.97	86-GW22IW-01	3/26	12%	18	0/3	50	0/3	50	0/3

TABLE 6-3 (Continued)

CONTAMINANTS OF POTENTIAL CONCERN
 IN GROUNDWATER
 SITE 86, ABOVEGROUND STORAGE TANK AREA
 REMEDIAL INVESTIGATION CTO-0303
 MCAS, NEW RIVER, NORTH CAROLINA

Contaminant	Minimum	Maximum	Lognormal UCL	Location of Maximum	Frequency	Frequency Percent	Tap Water RBC	Exceedance Frequency	Federal MCL	Exceedance Frequency	NCWQS	Exceedance Frequency
Inorganics (µg/L) (Continued)												
Sodium	5,340	98,200	37,922.64	86-GW17DW-01	26/26	100%	NA	NA	NA	NA	NA	NA
Vanadium	100	100	3.94	86-GW11-01	1/26	4%	26	1/1	NA	NA	NA	NA
Zinc	3.9	38.7	11.79	86-GW15IW-01	8/26	31%	1,100	0/8	NA	NA	2100	0/8

Notes:

COPCs indicated by the shaded areas.

¹ The residential soil RBC for manganese is based on an oral RfD of 0.14 mg/kg/day and not 0.005 mg/kg/day, as listed in the Region III RBC table (October, 1995). The latter toxicity value has been withdrawn from IRIS.

TABLE 6-4

SUMMARY OF EXPOSURE DOSE INPUT PARAMETERS
 SITE 86, ABOVEGROUND STORAGE TANK AREA
 REMEDIAL INVESTIGATION CTO-0303
 MCAS, NEW RIVER, NORTH CAROLINA

Input Parameter	Units	Receptor					
		Trespasser Child	Trespasser Adult	Military Personnel	Construction Worker	Residential Child	Residential Adult
Soil (mg/kg)							
Ingestion Rate, IR	mg/d	200	50	100	480	200	100
Fraction Ingested, FI	unitless	1	1	1	1	1	1
Exposure Frequency, EF	d/y	130	43	250	90	350	350
Exposure Duration, ED	y	6	30	4	1	6	30
Surface Area, SA	cm ²	2,000	5,000	4,300	4,300	2,300	5,800
Adherence Factor, AF	mg/cm ²	1	1	1	1	1	1
Averaging Time, Noncarc., ATnc	d	2,190	10,950	1,460	365	2,190	10,950
Averaging Time, Carc., ATcarc	d	25,550	25,550	25,550	25,550	25,550	25,550
Body Weight, BW	kg	15	70	70	70	15	70
Conversion Factor, CF	kg/mg	1x10 ⁻⁶	1x10 ⁻⁶	1x10 ⁻⁶	1x10 ⁻⁶	1x10 ⁻⁶	1x10 ⁻⁶
Absorbance Factor, ABS	unitless	Organics = 0.01; Inorganics = 0.001					
Groundwater (mg/L)							
Ingestion Rate, IR	L/d	NA	NA	NA	NA	1	2
Exposure Frequency, EF	d/y	NA	NA	NA	NA	350	350
Exposure Duration, ED	y	NA	NA	NA	NA	6	30
Exposure Time, ET	h/d	NA	NA	NA	NA	0.25	0.25
Surface Area, SA	cm ²	NA	NA	NA	NA	10,000	23,000
Averaging Time, Noncarc., ATnc	d	NA	NA	NA	NA	2,190	10,950
Averaging Time, Carc., ATcarc	d	NA	NA	NA	NA	25,550	25,550
Conversion Factor, CF	L/cm ³	NA	NA	NA	NA	0.001	0.001
Body Weight, BW	kg	NA	NA	NA	NA	15	70

TABLE 6-4 (Continued)

SUMMARY OF EXPOSURE DOSE INPUT PARAMETERS
 SITE 86, ABOVEGROUND STORAGE TANK AREA
 REMEDIAL INVESTIGATION CTO-0303
 MCAS, NEW RIVER, NORTH CAROLINA

Input Parameter	Units	Receptor					
		Trespasser Child	Trespasser Adult	Military Personnel	Construction Worker	Residential Child	Residential Adult
Air (mg/m³)							
Outdoor Air							
Inhalation Rate, IR	m ³ /d	15	20	30	20	15	20
Exposure Frequency, EF	d/y	130	43	250	90	350	350
Exposure Duration, ED	y	6	30	4	1	6	30
Averaging Time, Noncarc., ATnc	d	2,190	10,950	1,460	365	2,190	10,950
Averaging Time, Carc., ATcarc	d	25,550	25,550	25,550	25,550	25,550	25,550
Body Weight, BW	kg	15	70	70	70	15	70
Shower Air							
Inhalation Rate, IR	m ³ /h	NA	NA	NA	NA	0.6	0.6
Exposure Time, ET	h/d	NA	NA	NA	NA	0.25	0.25
Exposure Frequency, EF	d/y	NA	NA	NA	NA	350	350
Exposure Duration, ED	y	NA	NA	NA	NA	6	30
Averaging Time, Noncarc., ATnc	d	NA	NA	NA	NA	2,190	10,950
Averaging Time, Carc., ATcarc	d	NA	NA	NA	NA	25,550	25,550
Body Weight, BW	kg	NA	NA	NA	NA	15	70

References:

- USEPA Risk Assessment For Superfund Volume I. Human Health Manual (Part A) Interim Final, December, 1989.
- USEPA Exposure Factors Handbook, July, 1989.
- USEPA Risk Assessment For Superfund Volume I. Human Health Evaluation Manual Supplemental Guidance. "Standard Default Exposure Factors" Interim Final. March 25, 1991.
- USEPA Dermal Exposure Assessment: Principles and Applications. Interim Report. January, 1992.
- USEPA Region IV Guidance for Soil Absorbance. (USEPA, 1992)

TABLE 6-4 (Continued)

**SUMMARY OF EXPOSURE DOSE INPUT PARAMETERS
SITE 86, ABOVEGROUND STORAGE TANK AREA
REMEDIAL INVESTIGATION CTO-0303
MCAS, NEW RIVER, NORTH CAROLINA**

Notes:

The exposure frequency for the trespasser receptors is based on the typical exposure pattern (i.e., more time spent outdoors in the warmer months vs. the cooler months) for people who actively garden or play outdoors. It is an upper-bound estimate (USEPA, 1992).

The skin surface area for the trespasser receptors is based on approximately 25 percent of the total surface body area for a child and adult receptor. These values are upper-bound estimates.

TABLE 6-5

**SUMMARY OF EXPOSURE PATHWAYS
SITE 86, ABOVEGROUND STORAGE TANK AREA
REMEDIAL INVESTIGATION, CTO-0303
MCAS, NEW RIVER, NORTH CAROLINA**

Receptor	Exposure Pathway
Current Military Personnel	Surface soil ingestion, dermal contact and fugitive dust inhalation
Current Adult and Child Trespassers	Surface soil ingestion, dermal contact and fugitive dust inhalation
Future Construction Worker	Surface and subsurface soil ingestion, dermal contact, and fugitive dust inhalation
Future Residential Adult and Child	Subsurface soil ingestion, dermal contact and fugitive dust inhalation Groundwater ingestion, dermal contact and inhalation

TABLE 6-6

SUMMARY OF HEALTH-BASED CRITERIA
 SITE 86, ABOVEGROUND STORAGE TANK AREA
 REMEDIAL INVESTIGATION CTO-0303
 MCAS, NEW RIVER, NORTH CAROLINA

Contaminant	Oral RfD mg/kg/d	Inhalation RfD mg/kg/d	Oral CSF (mg/kg/d) ⁽¹⁾	Inhalation CSF (mg/kg/d) ⁽¹⁾	Weight-of-Evidence ⁽¹⁾
1,2-Dichloroethene (total)	9.00E-03 (h)	--	--	--	D
Trichloroethene	6.00E-03 (e)	--	1.10E-02 (w)	6.00E-03 (e)	B2
Benzene	--	1.71E-03 (e)	2.90E-02 (i)	2.90E-02 (i)	A
Tetrachloroethene	1.00E-02 (i)	--	5.20E-02 (e)	2.03E-03 (e)	--
Benzo(a)anthracene	--	--	7.30E-01 (e)	6.10E-01 (e)	B2
Benzo(b)fluoranthene	--	--	7.30E-01 (e)	6.10E-01 (e)	B2
Benzo(a)pyrene	--	--	7.30E+00 (i)	6.10E+00 (w)	B2
Indeno(1,2,3-cd)pyrene	--	--	7.30E-01 (e)	6.10E-01 (e)	B2
Dibenzo(a,h)anthracene	--	--	7.30E+00 (e)	6.10E+00 (e)	B2
Dieldrin	5.00E-05 (i)	--	1.60E+01 (i)	1.61E+01 (i)	B2
Aluminum	1.00E+00 (e)	--	--	--	--
Antimony	4.00E-04 (i)	--	--	--	--
Arsenic	3.00E-04 (i)	--	1.5E+00 (i)	1.51E+01 (i)	A
iron	3.00E-01 (e)	--	--	--	--
Lead	--	--	--	--	B2
Manganese	1.40E-01(i)	1.43E-05 (i)	--	--	--
Vanadium	7.00E-03 (h)	--	--	--	D

Notes:

⁽¹⁾ Drinking Water Regulations and Health Advisories by Office of Water, USEPA, May, 1995.

i = Integrated Risk Information System (IRIS, 1995)

e = Environmental Criteria and Assessment office (ECAO) (as cited from October 1995 USEPA, Region III RBC Tables)

h = Health Effects Assessment Summary Tables (HEAST, 1995)

a = HEAST Alternative Method, 1994

w = Withdrawn from IRIS or HEAST

-- = Information not published or applicable.

TABLE 6-7

**SUMMARY OF DERMALLY ADJUSTED
HEALTH-BASED CRITERIA
SITE 86, ABOVEGROUND STORAGE TANK AREA
REMEDIAL INVESTIGATION CTO-0303
MCAS, NEW RIVER, NORTH CAROLINA**

Contaminant	Percent Absorbed ⁽¹⁾	Oral RfD mg/kg/d	Dermally Adjusted Oral RfD, mg/kg/d	Oral CSF (mg/kg/d) ⁻¹	Dermally Adjusted Oral CSF, (mg/kg/d) ⁻¹
1,2-Dichloroethene (total)	80%	9.00E-03	7.2E-03	--	--
Trichloroethene	80%	6.00E-03	4.8E-03	1.10E-02	1.4E-02
Benzene	80%	--	--	2.90E-02	3.6E-02
Tetrachloroethene	80%	1.00E-02	8.0E-03	5.20E-02	6.5E-02
Benzo(a)anthracene	50%	--	--	7.30E-01	1.5E+00
Benzo(b)fluoranthene	50%	--	--	7.30E-01	1.5E+00
Benzo(a)pyrene	50%	--	--	7.30E+00	1.5E+01
Indeno(1,2,3-cd)pyrene	50%	--	--	7.30E-01	1.5E+00
Dibenzo(a,h)anthracene	50%	--	--	7.30E+00	1.5E+01
Dieldrin	50%	5.00E-05	2.5E-05	1.60E+01	3.2E+01
Aluminum	20%	1.00E+00	2.0E-01	--	--
Antimony	20%	4.00E-04	8.0E-05	--	--
Arsenic	20%	3.00E-04	6.0E-05	1.5E+00	7.5E+00
Iron	20%	3.00E-01	6.0E-02	--	--
Lead	20%	--	--	--	--
Manganese	20%	1.40E-01	2.8E-02	--	--
Vanadium	20%	7.00E-03	1.4E-03	--	--

Notes:

⁽¹⁾ Region IV recommended values (i.e., 80% for VOCs, 50% for SVOCs, and 20% for inorganics)

RfD = USEPA-verified reference dose

CSF = USEPA-verified cancer slope factor

-- = No toxicity value is available or applicable

Dermally-adjusted RfD = oral RfD * percent absorbed

Dermally-adjusted CSF = oral CSF / percent absorbed

TABLE 6-8

SUMMARY OF RISKS FOR THE
MILITARY RECEPTOR
SITE 86, ABOVEGROUND STORAGE TANK AREA
REMEDIAL INVESTIGATION CTO-0303
MCAS, NEW RIVER, NORTH CAROLINA

Exposure Pathway	Noncarcinogenic Risk	Carcinogenic Risk
Surface Soil		
Ingestion	2.8E-02	5.5E-07
Dermal Contact	6.7E-03	3.8E-07
Inhalation	--	4.0E-10
Total Risk	3.5E-02	9.3E-07

Notes:

-- = Not Applicable

TABLE 6-9

SUMMARY OF RISKS FOR THE
CHILD TRESPASSER
SITE 86, ABOVEGROUND STORAGE TANK AREA
REMEDIAL INVESTIGATION CTO-0303
MCAS, NEW RIVER, NORTH CAROLINA

Exposure Pathway	Noncarcinogenic Risk	Carcinogenic Risk
Surface Soil		
Ingestion	6.9E-02	2.0E-06
Dermal Contact	7.5E-03	6.4E-07
Inhalation	--	7.3E-10
total	7.6E-02	2.6E-06

Notes:

-- = Not Applicable

TABLE 6-10

SUMMARY OF RISKS FOR THE
 FUTURE CHILD RESIDENT
 SITE 86, ABOVEGROUND STORAGE TANK AREA
 REMEDIAL INVESTIGATION CTO-0303
 MCAS, NEW RIVER, NORTH CAROLINA

Exposure Pathway	Noncarcinogenic Risk	Carcinogenic Risk
Subsurface Soil		
Ingestion	7.2E-01	3.3E-06
Dermal Contact	4.2E-02	1.9E-07
Inhalation	--	1.9E-09
total	7.6E-01	3.5E-06
Groundwater		
Ingestion	18	5.8E-05
Dermal Contact	2.4E-01	1.1E-06
Inhalation	1.8E-01	1.3E-06
total	19	6.1E-05
Future Risk	20	6.4E-05

Notes:

-- = Not Applicable

Bolded values indicate risk values that exceed the acceptable risk value of 1.0 for noncarcinogenic effects.

TABLE 6-11

SUMMARY OF RISKS FOR THE
ADULT TRESPASSER
SITE 86, ABOVEGROUND STORAGE TANK AREA
REMEDIAL INVESTIGATION CTO-0303
MCAS, NEW RIVER, NORTH CAROLINA

Exposure Pathway	Noncarcinogenic Risk	Carcinogenic Risk
Surface Soil		
Ingestion	2.4E-03	3.5E-07
Dermal Contact	1.3E-03	5.7E-07
Inhalation	--	3.4E-10
Total Risk	3.8E-03	9.2E-07

Notes:

-- = Not Applicable

TABLE 6-12

SUMMARY OF RISKS FOR THE
 FUTURE ADULT RESIDENT
 SITE 86, ABOVEGROUND STORAGE TANK AREA
 REMEDIAL INVESTIGATION CTO-0303
 MCAS, NEW RIVER, NORTH CAROLINA

Exposure Pathway	Noncarcinogenic Risk	Carcinogenic Risk
Subsurface Soil		
Ingestion	7.7E-02	1.8E-06
Dermal Contact	2.2E-02	5.1E-07
Inhalation	--	2.7E-09
total	1.0E-01	2.3E-06
Groundwater		
Ingestion	7.9	1.2E-04
Dermal Contact	1.2E-01	2.8E-06
Inhalation	2.9E-02	1.1E-06
total	8.0	1.3E-04
Future Risk	8.1	1.3E-04

Notes:

-- = Not Applicable

Bolded values indicate risk values that exceeded the acceptable risk value of 1.0 for noncarcinogenic effects or 1×10^{-4} for carcinogenic effects.

TABLE 6-13

SUMMARY OF RISKS FOR THE
 CONSTRUCTION WORKER
 SITE 86, ABOVEGROUND STORAGE TANK AREA
 REMEDIAL INVESTIGATION CTO-0303
 MCAS, NEW RIVER, NORTH CAROLINA

Exposure Pathway	Noncarcinogenic Risk	Carcinogenic Risk
Surface Soil		
Ingestion	4.9E-02	2.4E-07
Dermal Contact	2.4E-03	3.4E-08
Inhalation	--	2.4E-11
total	5.1E-02	2.7E-07
Subsurface Soil		
Ingestion	9.5E-02	7.2E-08
Dermal Contact	4.3E-03	3.2E-09
Inhalation	--	2.3E-11
total	1.0E-01	7.5E-08
TOTAL	1.5E-01	3.5E-07

TABLE 6-14

SUMMARY OF UNCERTAINTIES IN THE RESULTS OF THE
HUMAN HEALTH RISK ASSESSMENT
SITE 86, ABOVEGROUND STORAGE TANK AREA
REMEDIAL INVESTIGATION CTO-0303
MCAS, NEW RIVER, NORTH CAROLINA

	Potential Magnitude for Over-Estimation of Risks	Potential Magnitude for Under-Estimation of Risks	Potential Magnitude for Over or Under-Estimation of Risks
<u>Environmental Sampling and Analysis</u>			
Sufficient samples may not have been taken to characterize the media being evaluated.			Low
Systematic or random errors in the chemical analysis may yield erroneous data.			Low
<u>Selection of COPCs</u>			
The use of USEPA Region III COPC screening concentrations in selecting COPCs in soil and groundwater.			Low
<u>Exposure Assessment</u>			
The standard assumptions regarding body weight, exposure period, life expectancy, population characteristics, and lifestyle may not be representative of the actual exposure situations.			Moderate
The use of the 95th percentile upper confidence level data of the lognormal distribution in the estimation of the RME.			Low
Assessing future residential property use when the likelihood of residential development is low.	High		
The amount of media intake is assumed to be constant and representative of any actual exposure.			Low
<u>Toxicological Assessment</u>			
Toxicological indices derived from high dose animal studies, extrapolated to low dose human exposure.	Moderate		
Lack of promulgated toxicological indices for inhalation pathway.		Low	
<u>Risk Characterization</u>			
Assumption of additivity in the quantitation of cancer risks without consideration of synergism, antagonism, promotion and initiation.			Moderate

TABLE 6-14 (Continued)

**SUMMARY OF UNCERTAINTIES IN THE RESULTS OF THE
HUMAN HEALTH RISK ASSESSMENT
SITE 44-JONES STREET DUMP
REMEDIAL INVESTIGATION, CTO-0303
MCB, CAMP LEJEUNE, NORTH CAROLINA**

	Potential Magnitude for Over-Estimation of Risks	Potential Magnitude for Under-Estimation of Risks	Potential Magnitude for Over or Under-Estimation of Risks
Assumption of additivity in the estimation of systemic health effects without consideration of synergism, antagonism, etc.			Moderate
Additivity of risks by individual exposure pathways (dermal and ingestion and inhalation).	Low		Low
Compounds not quantitatively evaluated.		Low	

Notes:

- Low = Assumptions categorized as "low" may effect risk estimates by less than one order of magnitude.
- Moderate = Assumptions categorized as "moderate" may effect estimates of risk by between one and two orders of magnitude.
- High = Assumptions categorized as "high" may effect estimates of risk by more than two orders of magnitude.

Source: Risk Assessment Guidance for Superfund, Volume 1, Part A: Human Health Evaluation Manual. USEPA, 1989a.

TABLE 6-15

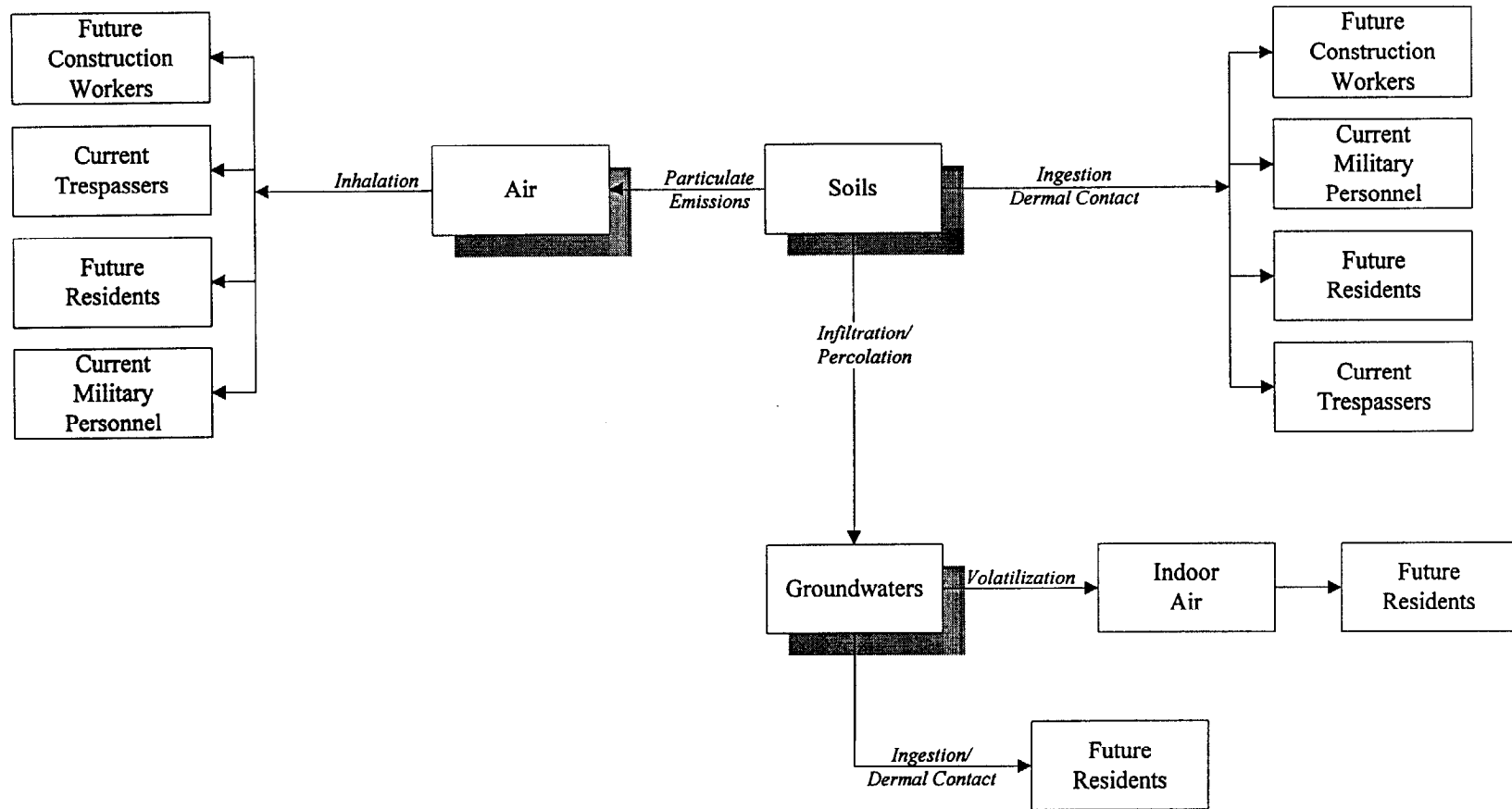
SUMMARY OF CONTAMINANTS CONTRIBUTING TO SITE RISKS
SITE 86, ABOVEGROUND STORAGE TANK AREA
REMEDIAL INVESTIGATION CTO-0303
MCAS, NEW RIVER, NORTH CAROLINA

Exposure Medium	Contaminant	Concentration
Groundwater	Antimony	0.011 mg/L (<i>Lognormal UCL</i>)
	Arsenic	0.007 mg/L (<i>Lognormal UCL</i>)
	Iron	68.3 mg/L (<i>maximum</i>)
	Lead	0.0283 mg/L (<i>maximum</i>)

SECTION 6.0 FIGURES

FIGURE 6-1

FLOWCHART OF POTENTIAL EXPOSURE PATHWAYS AND RECEPTORS
SITE 86: ABOVEGROUND STORAGE TANK AREA



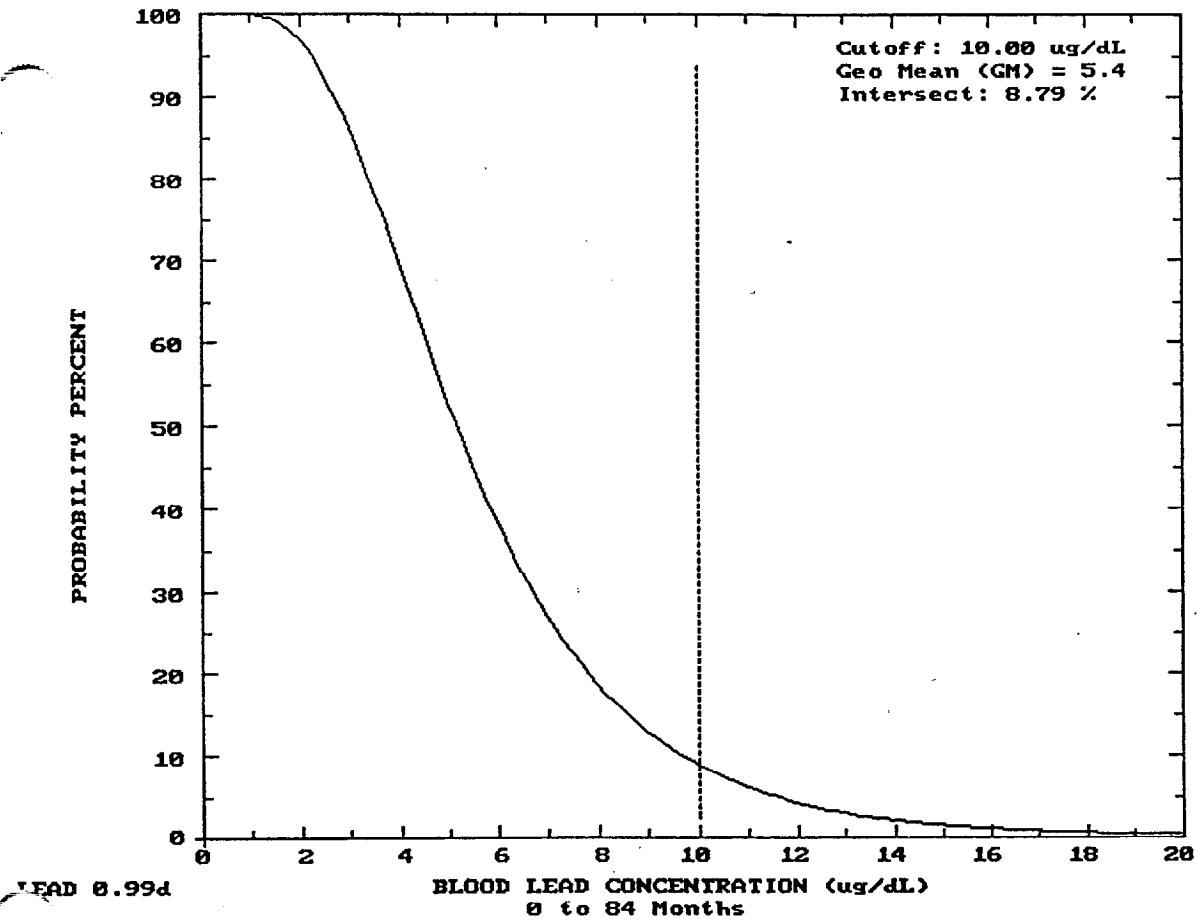


Figure 6-2
Cumulative Probability Percent of Blood Lead Levels
Site 86 Groundwater Exposure

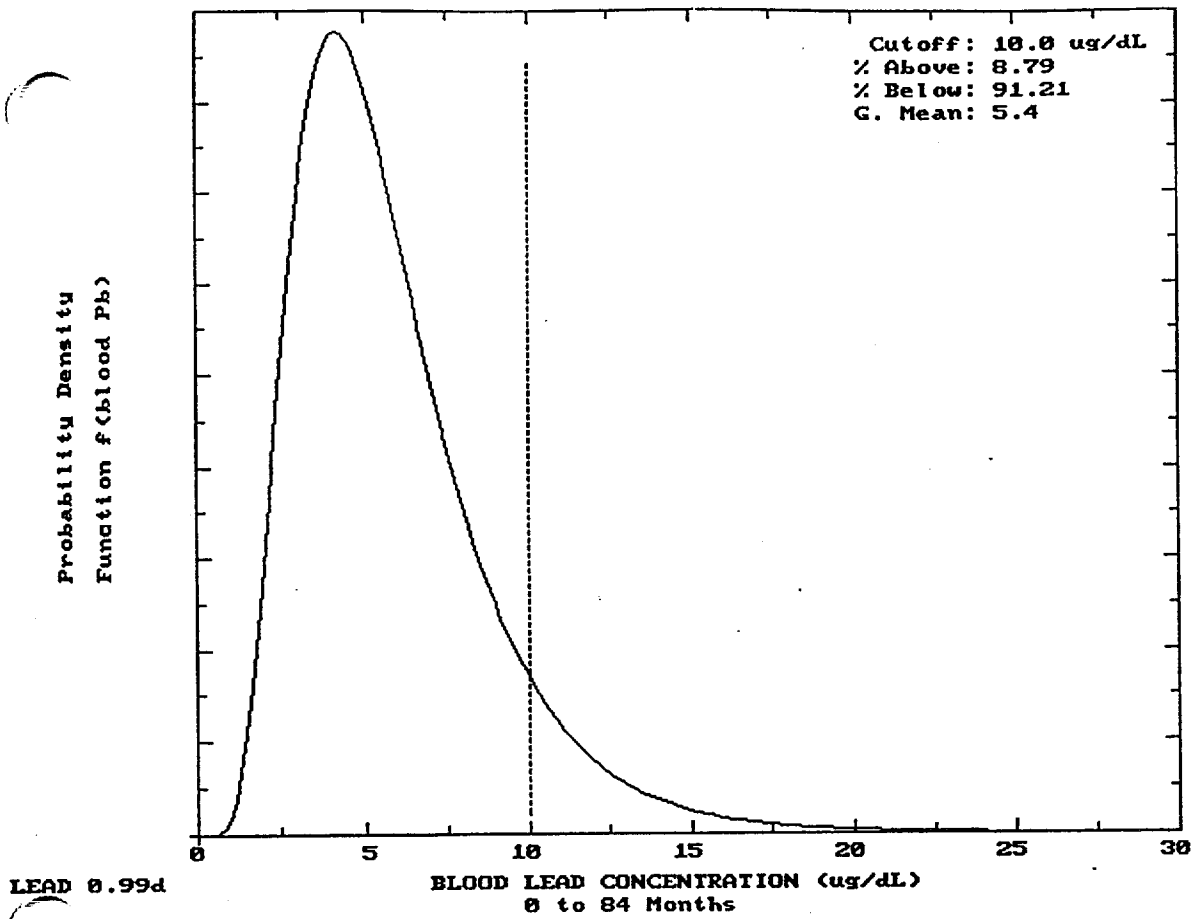


Figure 6-3
Probability Distribution of Blood Lead Levels
Site 86 Groundwater Exposure

7.0 ECOLOGICAL RISK ASSESSMENT

The Comprehensive Environmental Response, Compensation, and Liability Act of 1980 (CERCLA) as amended by the Superfund Amendments and Reauthorization Act (SARA) of 1986, directs USEPA to protect human health and the environment with respect to releases or potential releases of contaminants from abandoned hazardous waste sites (USEPA, 1989a). This section of the report presents the ecological risk assessment (ERA) conducted at Operable Unit No. 6, Site 86 and assesses the potential impacts to ecological receptors from contaminants detected at this site.

7.1 Objectives, Scope, and Organization of the Ecological Risk Assessment

The objective of this ERA is to evaluate if past reported disposal practices at Site 86 are potentially adversely impacting the terrestrial and aquatic communities on, or adjacent to, the site. This assessment also evaluates the potential effects of contaminants related to Site 86 on sensitive environments including wetlands and protected species. The conclusions of the ERA are used in conjunction with the human health risk assessment to evaluate the appropriate remedial action for this site for the overall protection of public health and the environment. If potential risks are characterized for the ecological receptors, further ecological evaluation of the site and surrounding areas may be warranted.

This ERA evaluates and analyzes the results from the Remedial Investigation (RI) including chemical analysis of the soil and groundwater. The media of concern for this ERA is the surface soil. Information used to evaluate sensitive environments is obtained from historical data and previous studies obtained in the literature, or through conversations with appropriate state, Federal, and local personnel.

The risk assessment methodologies used in this evaluation are consistent with those outlined in the Ecological Risk Assessment Guidance for Superfund: Process for Designing and Conducting Ecological Risk Assessments (USEPA, 1994) and Framework for Ecological Risk Assessment (USEPA, 1992). In addition, information found in the following documents was used to supplement the USEPA guidance document:

- USEPA Supplemental Risk Assessment Guidance for Superfund. Volume II. Environmental Evaluation Manual (USEPA, 1989b)
- Ecological Assessment of Hazardous Waste Sites: A Field and Laboratory Reference (USEPA, 1989c)

Based on the USEPA Framework for Ecological Risk Assessment, an ERA consists of three main components: 1) Problem Formulation; 2) Analysis; and, 3) Risk Characterization (USEPA, 1992). The problem formulation section includes a preliminary characterization of exposure and effects of the stressors to the ecological receptors. During the analysis, the data is evaluated to determine the exposure and potential effects on the ecological receptors from the stressors. Finally, in the risk characterization, the likelihood of adverse effects occurring as a result of exposure to a stressor is evaluated. This section also evaluates the potential impact on the ecological receptors at the site from the contaminants detected in the media. This ERA is organized to parallel these three components.

7.2 Problem Formulation

Problem formulation is the first step of an ERA and includes a preliminary characterization of exposure and effects (USEPA, 1992a). Chemical analyses were performed on samples collected from the soil to evaluate the presence, concentrations, and variabilities of the contaminants. A habitat characterization also was conducted as part of the field activities. Based on these observations, potential ecological receptors were identified. Finally, toxicological information for the contaminants detected in the media was obtained from available references and literature and used to evaluate the potential adverse ecological effects to the ecological receptors.

The components of the problem formulation include identifying the stressors and their potential ecological effects, identification of ecosystems potentially at risk, defining ecological endpoints and presenting a conceptual model. The following sections discuss each of these components, and how they are evaluated in this ERA.

7.3 Contaminants of Potential Concern

One of the initial steps in the problem formulation stage of an ERA is identifying the stressors and their potential ecological effects. For this ERA, the stressors that are evaluated include contaminants detected in the surface soil. Contaminants in the subsurface soil and groundwater are not evaluated in this ERA. Some terrestrial species burrow in the subsurface soil, however, current guidance does not provide sufficient information to evaluate risk to these receptors. In addition, no water bodies are located adjacent to the site, to which the groundwater may discharge.

The nature and extent of contaminants detected in the environmental media at Site 86 are presented in Section 4.0 of this report. Sample locations are based on available historical site information and a site visit to evaluate potential ecosystems and ecological receptors.

7.3.1 Criteria for Selecting Contaminants of Potential Concern

Quantifying risk for all positively identified contaminants may distract from the dominant risk-driving contaminants at the site. Therefore, the data set was reduced to a list of contaminants of potential concern (COPCs). COPCs are site-related contaminants used to quantitatively estimate ecological exposures and associated potential ecological effects.

The criteria used in selecting the COPCs from the contaminants detected during the field sampling and analytical phase of the investigation are:

- Historical information
- Prevalence
- Toxicity
- Comparison to Federal and state criteria and standards
- Comparison to investigation associated field and laboratory blank data
- Comparison to background or naturally occurring levels
- Comparison to anthropogenic levels

7.3.1.1 Historical Information

Using historical information to associate contaminants with site activities, when combined with the following selection procedures, helps determine contaminant retention or elimination. To be conservative, contaminants detected in the media that may not have been historically used at a site are retained as COPCs to evaluate risk, but may be eliminated in the ecological significance section as not being site-related.

7.3.1.2 Prevalence

The frequency of positive detections in sample sets and the level at which a contaminant is detected in a given medium are factors that determine a chemical's prevalence. Contaminants that were detected infrequently are not retained as COPCs.

7.3.1.3 Toxicity

The potential toxicity of a contaminant is an important consideration when selecting COPCs for further evaluation in the ERA. Several of the contaminants detected in the media at Site 86 are prevalent, however, their inherent toxicity to aquatic and terrestrial receptors is low (e.g., calcium, magnesium, potassium, and sodium). Therefore, they are not retained as COPCs. In addition, several contaminants have not been adequately studied to develop published toxicity values, or even accepted toxicological data with which to assess the contaminants. Contaminants that fall into this category are retained as COPCs (if they are not eliminated due to other criteria), however, they are not quantitatively evaluated in the ERA.

7.3.1.4 State and Federal Criteria and Standards

There are no state or Federal soil screening values that can be used to evaluate potential ecological risks to terrestrial receptors (other than plants or invertebrates). Therefore, toxicity of contaminants in the surface soil to terrestrial receptors is not used as criteria for retaining COPCs except for calcium, magnesium, potassium, and sodium, which are not retained as COPCs in any of the media.

7.3.1.5 Field and Laboratory Blank Data

Associating contaminants detected in field related blanks (i.e., trip blanks, equipment rinsates and/or field blanks) or laboratory method blanks with the same contaminants detected in analytical samples can eliminate non-site-related contaminants from the list of COPCs. Blank data should be compared to sample results with which the blanks are associated. However, for this data set it is difficult to associate specific blanks with specific environmental samples. Thus, in order to evaluate detection levels, maximum contaminant concentrations reported in a given set of blanks are applied to a corresponding set of samples.

In accordance with the National Functional Guidelines for Organics, common lab contaminants (i.e., acetone, 2-butanone, methylene chloride, toluene, and phthalate esters) should be regarded as a direct result of site activities only when sample concentrations exceed 10 times the maximum blank concentration. For other contaminants not considered common in a lab, concentrations exceeding 5 times the maximum blank concentration indicate contamination resulting from site activities (USEPA, 1991).

Contract Required Quantitation Limits (CRQLs) and percent moisture are employed when evaluating contaminant concentrations in soil, in order to correlate solid and aqueous detection limits. For example, the CRQL for semivolatiles in soil is 33 to 66 times that of aqueous samples, depending on the contaminant. In order to assess semivolatile contaminant levels in soil using aqueous blanks, the blank concentration must then also be multiplied by 33 or 66 to account for variance from the CRQL (common lab contaminants must first be multiplied by 5 or 10, as explained in the paragraph above). The final value is divided by the sample percent moisture.

Eliminating a sample result correlates directly to a reduction in the contaminant prevalence in that medium. Consequently, if elimination due to blank concentration reduces the prevalence of a contaminant to less than 5 percent, a contaminant that may have been included according to its prevalence is eliminated as a COPC.

Maximum concentrations of common laboratory contaminants detected in blanks are presented in Section 6.0, Table 6-1. Blanks containing organic constituents that are not considered common laboratory contaminants (i.e., all other TCL compounds) are regarded as positive results only when observed concentrations exceed 5 times the maximum concentration detected in any blank (USEPA, 1989a). All TCL compounds at less than 5 times the maximum level of contamination noted in any blank are considered not detected in that sample.

7.3.1.6 Background or Naturally Occurring Levels

Contaminants that were detected in the surface soil at concentrations less than two-times the average Base background concentration are not retained as COPCs.

7.3.1.7 Anthropogenic Levels

Ubiquitous anthropogenic background concentrations result from non-site related sources such as combustion of fossil fuels (i.e., automobiles), plant synthesis, natural fires and factories. Examples of ubiquitous, anthropogenic chemicals are polycyclic aromatic hydrocarbons (PAHs). Anthropogenic chemicals are typically not eliminated as COPCs without considering other selection criteria. It is difficult to determine that such chemicals are present at the site due to operations not related to the site or the surrounding area. Omitting anthropogenic background chemicals from the risk assessment may result in the loss of important information for those potentially exposed.

The following sections apply the aforementioned selection criteria beginning with the prevalence of detected analytical results in each medium of interest to establish a preliminary list of COPCs for Site 86. Once this task has been completed, a final list of media-specific COPCs will be selected based on the remaining criteria.

7.3.2 Selection of Contaminants of Potential Concern

The following sections present an overview of the analytical data obtained for each medium during the RI and the subsequent retention or elimination of COPCs using the aforementioned selection criteria. Contaminants that are not eliminated due to the above criteria are retained as COPCs. The primary reasons for retaining contaminants as COPCs include, but may not be limited to the following: (1) frequently detected, (2) detected at concentrations above the screening values (if available) and/or (3) detected at concentrations above background (if available). In addition, some common laboratory contaminants (i.e., phthalates) are retained as COPCs because they were

detected frequently and were not detected in the blank samples. Finally, calcium, magnesium, potassium, and sodium are not retained as COPCs in any of the media because they are common naturally occurring chemicals, are not related to the site, and no published toxicity data was identified to assess potential impacts to aquatic or terrestrial life.

A comparison of the surface soil contaminant concentrations to base-background concentrations is presented in Section 6.0, Table 6-3. A summary of the COPCs retained in each media is presented in Table 7-1.

The following sections present an overview of the analytical data obtained for each medium during the RI and the subsequent retention or elimination of COPCs using the aforementioned selection criteria. Calcium, magnesium, potassium, and sodium were not retained as COPCs in any of the media because they are common naturally occurring chemicals, are not related to the site, and no published toxicity data was identified to assess potential impacts to terrestrial life.

7.3.2.1 Surface Soil

Eighteen samples were collected at Site 86. All eighteen samples were analyzed for Target Compound List (TCL) volatile organic compounds (VOCs) and semivolatile organic compounds (SVOCs), while eleven samples were analyzed for TCL pesticides/PCBs, and Target Analyte List (TAL) metals.

Three VOCs were detected in the surface soil samples. All three VOCs (acetone, toluene, and xylenes) are retained as COPCs. Twenty SVOCs were detected in the surface soil samples. All the SVOCs (acenaphthene, anthracene, benzo(a)anthracene, benzo(b)fluoranthene, benzo(k)fluoranthene, benzo(a)pyrene, benzo(g,h,i)perylene, bis(2-ethylhexyl)phthalate, butylbenzylphthalate, carbazole, chrysene, dibenzo(a,h)anthracene, dibenzofuran, fluoranthene, fluorene, indeno(1,2,3-cd)pyrene, 2-methylnaphthalene, naphthalene, phenanthrene, and pyrene) are retained as COPCs.

Six pesticides were detected in the surface soil samples. All six pesticides (aldrin, 4,4'-DDD, 4,4'-DDE, 4,4'-DDT, dieldrin, and heptachlor epoxide) are retained as COPCs.

Nineteen metals were detected in the surface soil samples. Cobalt and selenium are not retained as COPCs because they were detected at concentrations of less than two times the average base background concentration. As presented above, calcium, magnesium, potassium, and sodium are not retained as COPCs. The remaining thirteen metals (aluminum, arsenic, barium, cadmium, chromium, copper, iron, lead, manganese, mercury, nickel, vanadium, and zinc) are retained as COPCs.

7.3.3 Physical/Chemical Characteristics of COPCs

Physical and chemical characteristics of contaminants may affect their mobility, transport, and bioavailability in the environment. These characteristics include bioconcentration factors (BCFs), organic carbon partition coefficient (K_{oc}), octanol water partition coefficient (K_{ow}), and biotransfer factors (B_v, B_b, B_r). Table 7-2 summarizes these values for the COPCs detected in the surface soil. Information from these tables is used to assess the fate and transport of the contaminants and the potential risks to the environmental receptors at Site 86. The following paragraphs present the significance of each parameter included in the table.

Bioconcentration factors measure the tendency for a chemical to partition from the water column or sediment and concentrate in aquatic organisms. Bioconcentration factors are important for ecological receptors because chemicals with high BCFs could accumulate in lower-order species and subsequently accumulate to toxic levels in species higher up the food chain. The BCF is the concentration of the chemical in the organism at equilibrium divided by the concentration of the chemical in the water. Therefore, the BCF is unitless. The bioconcentration factor is used to evaluate a contaminant's bioconcentration potential in ecological receptors.

The organic carbon partition coefficient (K_{oc}) measures the tendency for a chemical to partition between soil or sediment particles containing organic carbon and water. This coefficient is important in the ecological environment because it determines how strongly an organic chemical will be bound to the organics in the soil and sediment.

The octanol/water partition coefficient (K_{ow}) is the ratio of a chemical concentration in octanol divided by the concentration in water. The octanol/water partition coefficient has been shown to correlate well with bioconcentration factors in aquatic organisms and with adsorption to soil or sediment. The K_{ow} is used to calculate the plant and beef biotransfer factors (for organics) that are used to estimate the COPC concentration in plants and the small mammal that would potentially be ingested by the terrestrial receptors in the intake model.

The plant biotransfer factors (B_v or B_r) measure the potential for a chemical to accumulate in a plant. These factors are used to calculate the concentration of the COPCs in either the leafy part of the plant (B_v) or the fruit of the plant (B_r). The factors for inorganics are obtained from Baes et. al., 1984, while the factors for organics are calculated according to Travis and Arms, 1988. The B_v and B_r values for the organics are assumed to be same value.

Finally, the beef biotransfer factor (B_b) measures the potential for a chemical to accumulate in an animal. This factor is used to calculate the COPC concentration in the small mammal that is ingested by the red fox. The factors for inorganics are obtained from Baes et. al., 1984, while the factors for organics are calculated according to Travis and Arms, 1988.

7.4 Ecosystems Potentially at Risk

Ecological receptors that might be potentially at risk from contaminants at Site 86 were identified during the field investigations and the habitat evaluation. The regional and site-specific ecologies are presented in Section 1.0 and 2.0 of this report. Based on the results of the field investigations and the habitat evaluation, potential receptors of contaminants in soil include the following: deer, rabbits, foxes, raccoons, birds and other terrestrial flora and fauna.

7.5 Ecological Endpoints

The information compiled during the first stage of problem formulation (stressor characteristics and ecosystems potentially at risk) is used to select the ecological endpoints for this ERA. The following section presents the ecological endpoints selected for this ERA, and the reasons they are selected.

There are two primary types of ecological endpoints: assessment endpoints and measurement endpoints. Assessment endpoints are environmental characteristics, which, if they are found to be significantly affected, may indicate a need for remediation (e.g., decrease in sports/fisheries). Measurement endpoints are quantitative expressions of an observed or measured effect of the

contamination of concern. Measurement endpoints may be identical to assessment endpoints (e.g., measurement of abundance of fish), or they may be used as surrogates for assessment endpoints (e.g., toxicity test endpoints). Both types of endpoints are used in the ecological risk evaluation and are presented in the following sections.

A measurement endpoint, or "ecological effects indicator" as it is sometimes referred, is used to evaluate the assessment endpoint. Therefore, measurement endpoints must correspond to, or be predictive of, assessment endpoints. In addition, they must be readily measurable, preferably quickly and inexpensively, using existing techniques. Measurement endpoints must take into consideration the magnitude of the contamination and the exposure pathway. The measurement endpoint should be an indicator of effects that are temporally distributed. Low natural variability in the endpoint is preferred to aid in attributing the variability in the endpoint to the contaminant. Measurement endpoints should be diagnostic of the pollutants of interest, as well as broadly applicable to allow comparison between sites and regions. Also, measurement endpoints should be standardized (e.g., standard procedures for toxicity tests). Finally, it is desirable to use endpoints that already are being measured (if they exist) to determine baseline conditions.

7.5.1 Terrestrial Endpoints

The assessment endpoint for the terrestrial receptors is the potential reduction of a receptor population or subpopulation that is attributable to contaminants from the site. The measurement endpoints for the terrestrial ERA include exceedances of contaminant-specific soil effect concentrations (i.e., SSSVs) and contaminant-specific effect doses (TRVs).

7.6 Conceptual Model

This section of the ERA presents each potential exposure pathway via soil, groundwater and air, and the likelihood that an exposure will occur through these pathways. Figure 7-1 presents the flowchart of potential exposure pathways and ecological receptors.

To determine if ecological exposure via these pathways may occur in the absence of remedial actions, an analysis is conducted including the identification and characterization of the exposure pathways. The following four elements are examined to determine if a complete exposure pathway is present:

- A source and mechanism of chemical release
- An environmental transport medium
- A feasible receptor exposure route
- A receptor exposure point

7.6.1 Soil Exposure Pathway

Potential release sources to be considered in evaluating the soil pathway are surface or buried wastes and contaminated soil. The release mechanisms to be considered are fugitive dust, leaching, tracking, and surface runoff. The transport medium is the soil. The potential routes to be considered for ecological exposure to the contaminated soil are ingestion and dermal contact. Potential exposure points for ecological receptors include species living in, or coming in contact with, the soil. COPCs were detected in the surface soil demonstrating a release from a source to the surface soil transport medium. Potential receptors that may be exposed to contaminants in surface soil at/or

around surface soil in the areas of detected COPCs include the following: deer, fox, raccoon, rabbits, birds, plants, and other terrestrial life.

Terrestrial receptors potentially are exposed to contaminants in the soil through ingestion, dermal contact, and/or direct uptake (for flora). The magnitude of the exposure depends on their feeding habits and the amount of time they reside in the contaminated soil. In addition, terrestrial species may ingest organisms that have bioconcentrated contaminants from the soil. This exposure pathway is likely to occur at Site 86 and will be retained for further analysis.

7.6.2 Groundwater Exposure Pathway

The potential release source to be considered in evaluating the groundwater pathway is contaminated soil. The release mechanism to be considered is leaching. The routes to be considered for ecological exposure to the contaminated groundwater are ingestion and dermal contact.

Sub-surface biota (i.e., microorganisms) are the only ecological receptors expected to be directly exposed to groundwater. Potential impacts to these biota are not assessed in this ERA because current guidance does not provide sufficient information to evaluate risk, and there are no adjacent water bodies to which the groundwater would discharge.

7.6.3 Air Exposure Pathway

There are two potential release mechanisms to be considered in evaluating the atmospheric pathway: release of contaminated particulates and volatilization from surface soil, groundwater and surface water. The potential exposure points for receptors are areas on or adjacent to the site. The air exposure pathway is not evaluated in this ERA because air sampling was not conducted, and current guidance does not provide sufficient information to evaluate risk to ecological receptors.

7.7 Exposure Assessment

The next phase after the problem formulation is the exposure assessment that consists of quantifying the potential exposure of the stressors (COPCs) to the ecological receptors. The RI included collecting samples for analytical analysis from the soil and groundwater. The analytical results for the data used in ERA are presented in Section 4.0 of this report. The regional ecology, site ecology, and habitat characterization in the areas surrounding Site 86 are presented in Sections 1.0 and 2.0 of this report. Information on sensitive environments and endangered species also is included in this section.

Exposure of contaminants in the surface soil to terrestrial flora and fauna (invertebrates and microorganisms) is assumed to be equal to the contaminant concentration in the surface soil. It is noted in the uncertainty section of this ERA that all the contaminants in the surface soil may not be bioavailable to the terrestrial flora or fauna. Exposure of contaminants in the surface soil to other terrestrial fauna (mammals, birds) is estimated using chronic daily intake models (see Section 7.8.5 of this report).

7.8 Ecological Effects Characterization

The ecological effects data that were used to assess potential risks to terrestrial receptors in this ERA include aquatic and terrestrial screening values as presented in Section 7.3.2 to aid in the selection of the COPCs. The following sections present a summary of the ecological effects comparison.

7.8.1 Surface Soil

Although promulgated standards do not exist, Surface Soil Screening Values (SSSVs) that can be used to evaluate potential ecological risks to terrestrial flora and fauna have been developed by USEPA Region III (USEPA, 1995b) and Oak Ridge National Laboratory (Will and Suter, 1994a, 1994b). The contaminant concentrations in the surface soils are compared to the SSSVs to determine if potential impacts to terrestrial flora and fauna (invertebrates may be expected (see Table 7-3).

No VOCs exceeded the SSSVs. Thirteen SVOCs (acenaphthene, anthracene, benzo(a)anthracene, benzo(b)fluoranthene, benzo(k)fluoranthene, benzo(g,h,i)perylene, chrysene, dibenzo(a,h)anthracene, fluoranthene, fluorene, indeno(1,2,3-cd)pyrene, phenanthrene, and pyrene) and six metals (aluminum, chromium, copper, iron, mercury, and vanadium) were detected in the surface soil at concentrations exceeding the SSSVs. Finally, one pesticide (4',4-DDT) was detected in the surface soil at a concentration exceeding the SSSVs. Much of the study area at Site 86 is mowed grass or asphalt. Therefore, ecological receptors have a low potential for becoming exposed to contaminants in the surface soil due to the low availability of natural habitat.

7.8.5 Terrestrial Chronic Daily Intake Model

In addition to comparing the soil concentrations to toxicity values for terrestrial invertebrates and plants, a terrestrial Chronic Daily Intake (CDI) Model is used to estimate the exposure of the COPCs to terrestrial receptors. The following describes the procedures used to evaluate the potential soil exposure to terrestrial fauna at Site 86 by both direct and indirect exposure to COPCs via soil, and foodchain transfer.

Based on the regional ecology and potential habitat at the site, the indicator species used in this analysis are the white-tailed deer, cottontail rabbit, red fox, and the bobwhite quail. The exposure points for these receptors are the surface soil and biota. The routes for terrestrial exposure to the COPCs in the soil are incidental soil ingestion, vegetation (leafy plants, seeds and berries) ingestion, and ingestion of small mammals.

7.8.5.1 Derivation of Terrestrial Reference Value

Total exposure of the terrestrial receptors to the COPCs in the surface soil is determined by estimating the CDI dose and comparing this dose to Terrestrial Reference Values (TRVs) representing acceptable daily doses in mg/kg/day. The TRVs were developed from No-Observed-Adverse-Effect-Levels (NOAELs) or Lowest-Observed-Adverse-Effect-Levels (LOAELs) obtained from the Integrated Risk Information System (IRIS), Agency for Toxic Substances and Disease Registry Toxicological Profiles, mineral tolerance levels of domestic animals (NAS, 1992) or other toxicological data in the literature. Appendix T presents the methodology used in deriving the TRVs and the animals that were used to derive each TRV.

7.8.5.2 Calculation of Chronic Daily Intake

Potential impacts of the terrestrial receptors to the COPCs in the surface soil are determined by estimating the CDI dose and comparing this dose to TRVs representing acceptable daily doses in mg/kg/day. The CDI equations were adapted from those used in Scarano et. al., (1993). The estimated CDI dose of the bobwhite quail, cottontail rabbit, white-tailed deer and small mammal, to soil and vegetation was determined using the following equation:

$$CDI = \frac{[(Cs)(Bv)(Iv) + (Cs)(Is)][H]}{BW}$$

Where:

CDI	=	Chronic Daily Intake, mg/kg/d
Cs	=	Contaminant concentration in soil, mg/kg
Bv	=	Soil to plant transfer coefficient (leaves, stems, straw, etc.), unitless
Iv	=	Rate of vegetation ingestion, kg/d
Is	=	Incidental soil ingestion, kg/d
H	=	Contaminated area/Home area range area ratio, unitless
BW	=	Body weight, kg

To calculate the contaminant concentration in the small mammal, the resulting CDI from the above equation is multiplied by the biotransfer factor for beef (Bb) for organics (Travis and Arms, 1988) and metals (Baes, et. al., 1984).

The estimated CDI dose of the red fox is determined using the following equation:

$$CDI = \frac{(Cs)(Bv)(Iv) + (Cs)(Is) + (Cm)(Im)[H]}{BW}$$

Where:

CDI	=	Chronic Daily Intake, mg/kg/d
Cs	=	Contaminant concentration in soil, mg/kg
Bv	=	Soil to plant transfer coefficient (leaves, stems, straw, etc.), unitless
Iv	=	Rate of vegetation ingestion, kg/d
Is	=	Incidental soil ingestion, kg/d
Cm	=	Contaminant concentrations in small mammals, mg/kg
Im	=	Rate of small mammal ingestion, kg/d
H	=	Contaminated area/Home area range area ratio, unitless
BW	=	Body weight, kg

Bioconcentration of the COPCs to plants is calculated using the soil to plant transfer coefficient (Bv or Br) for organics (Travis and Arms, 1988) and metals (Baes et. al., 1984). The concentrations of the COPCs used in the models were the lower of the upper 95 percent confidence limit or the maximum concentration detected of each COPC. The exposure parameters used in the CDI calculations are presented in Table 7-4.

7.9 Risk Characterization

The risk characterization is the final phase of a risk assessment. It is at this phase that the likelihood of adverse effects occurring as a result of exposure to a stressor is evaluated. This section evaluates the potential decrease in aquatic and terrestrial populations at Site 86 from contaminants identified at the site.

A Quotient Index (QI) approach is used to characterize the risk to terrestrial receptors from exposure to contaminants in the surface soil. The QI is calculated as follows:

$$QI = \frac{(CDI)}{(TRV)}$$

Where: Quotient Index
 CDI = Chronic Daily Intake, mg/kg/day
 TRV = Terrestrial Reference Value, mg/kg/day

A QI of greater than "unity" is considered to be indicative of potential risk. Such values do not necessarily indicate that an effect will occur but only that a lower threshold has been exceeded. It is important to determine which contaminants are posing the highest risks, in order to evaluate the significance of those contaminants to the site. Therefore, the evaluation of the significance of the QI has been judged as follows: (Menzie et. al., 1993)

- QI exceeds "1" but less than "10": some small potential for environmental effects
- QI exceeds "10": significant potential that greater exposures could result in effects based on experimental evidence
- QI exceeds "100": effects may be expected since this represents an exposure level at which effects have been observed in other species

The risks characterized above provide insight into general effects upon animals and plants in the local population. However, depending on the endpoint selected, they may not indicate if population-level effects will occur.

7.9.1 Terrestrial Chronic Daily Intake Model

Table 7-5 presents the QI for the terrestrial CDI model. Appendix T contains the CDI spreadsheets. The cottontail rabbit (QI= 2.2) was the only species with a QI that exceeded "1". None of the individual COPC QIs exceeded "1" in the cottontail rabbit species.

7.10 Ecological Significance

This section essentially summarizes the overall risks to the ecology at the site. It addresses impacts to ecological receptors at Site 86 from the COPCs detected in the media, and determines which COPCs are impacting the site to the greatest degree, and what contaminants are site-related "significant". This information, to be used in conjunction with the human health risk assessment, supports the selection of remedial action(s) for Site 86 that are protective of public health and the environment.

7.10.1 Terrestrial Receptors

Several SVOCs, metals, and one pesticide were detected at concentrations exceeding the SSSVs. The habitat at Site 86 consists primarily of mowed grass and asphalt in the middle of an industrial area. Therefore, Site 86 is not expected to support an ecologically diverse terrestrial population that would be exposed to COPCs exceeding the SSSVs.

The cottontail rabbit (QI=2.2) was the only terrestrial vertebrate with a CDI QI that exceeded "1". Due to the habitat at Site 86 it is unlikely that the contaminants in the surface soil at Site 86 will significantly reduce the rabbit population.

7.10.3 Threatened and Endangered Species

No threatened or endangered species are expected to occur at Site 86.

7.10.4 Wetlands

No wetlands were observed at Site 86 during the field investigations.

7.11 Uncertainty Analysis

The procedures used in this evaluation to assess risks to ecological receptors, as in all such assessments, are subject to uncertainties. The following discusses some of the uncertainty in this ERA.

Potential adverse impacts to terrestrial invertebrates and plants were evaluated by comparing the COPC concentration in the soil to SSSVs. Most of these studies do not account for the soil type, which may have a large influence on the toxicity of the contaminants. For example, soil with high organic carbon content will tend to sorb many of the organic COPCs, thus making them less bioavailable to terrestrial receptors. In addition, most of the SSSVs are based on one or two studies, which greatly adds to their uncertainty.

There are some differences of opinion found in the literature as to the effectiveness of using models to predict concentrations of contaminants found in terrestrial species. According to one source, the food chain models currently used incorporate simplistic assumptions that may not represent actual site conditions, bioavailability of contaminants, or site-specific behavior of the receptors. Simple food chain models can provide an effective means of initial characterization of risk, however, residue analyses, toxicity tests, and the use of biomarkers provide a better approach for assessing exposure (Menzie et. al., 1993).

There are several sources of uncertainty when using these models. First, most of the terrestrial reference values are based on toxicity data from another species, which is then extrapolated to the species of concern using a body-size scaling equation. Since the toxicity of all contaminants may not be proportional to body size, the calculated TRVs may not accurately predict risk to the species of concern. Another source of uncertainty with the models is that many of the input parameters are based on default values (i.e., ingestion rate) that may or may not adequately represent the actual values of the parameters. In addition, there is uncertainty in the amount that the indicator species will represent other species potentially exposed to COPCs at the site. There is uncertainty in use of the bioconcentration and biotransfer factors. Bioconcentration and biotransfer factors can vary

widely from species to species. The species used in the calculation of the bioconcentration and biotransfer factors are different than the species that actually occur at the site. Therefore, use of the factors will tend to either overestimate or underestimate actual bioaccumulation of contaminants. Finally, terrestrial receptors also may be exposed to contaminants in the sediments. However, currently, there is no guidance in the literature that can be used to evaluate this potential exposure pathway.

The toxicity of chemical mixtures is not well understood. All the toxicity information used in the ERA for evaluating risk to the ecological receptors is for individual chemicals. Chemical mixtures can affect the organisms very differently than the individual chemicals due to synergistic or antagonistic effects. In addition, the species that were used to develop the toxicity data may not be present at the site, or have the potential to exist at the site. Depending on the sensitivity of the tested species to the species at the site use of the toxicity values may overestimate or underestimate risk. Many chemicals are not acutely toxic, however, they have the potential to bioaccumulate in ecological receptors through food chain transfer. This bioaccumulation potential typically is not taken into account when comparing contaminant concentrations to screening values.

Finally, toxicological data for several of the COPCs were limited or do not exist. Therefore, there is uncertainty in any conclusions involving the potential impacts to aquatic receptors from these contaminants

7.12 Conclusions

7.12.1 Terrestrial Receptors

As presented earlier in the ERA, the assessment endpoints for the terrestrial receptors are the potential reduction of a receptor population or subpopulation that is attributable to contaminants from the site. This section evaluates this assessment endpoint using the measurement endpoints.

The first measurement endpoint is to determine if there is an exceedance of contaminant-specific soil effect concentrations (i.e., SSSVs). Several COPCs were detected in the surface soils at concentrations exceeding the SSSVs. Therefore, there is a potential for adverse impacts to terrestrial flora, invertebrates, and/or microorganisms from these contaminants. It should be noted that the only habitat at Site 86 is mowed grass, with the remaining area consisting of buildings and asphalt. Therefore, ecological receptors have a low potential for becoming exposed to contaminants in the surface soil due to the availability of natural habitat.

The second measurement endpoint is to determine if the terrestrial CDI exceeds the TRVs. The cottontail rabbit is the only terrestrial species with estimated CDI values that exceeded the TRV values. The QI of rabbit (2.2) just slightly exceeded "1", and therefore the COPCs at Site 86 are not expected to impact terrestrial receptors (vertebrates).

Overall, some potential impacts to soil invertebrates and plants may occur as a result of site-related contaminants. As presented in more detail in the Uncertainty Analysis section of this ERA, there is much uncertainty in the SSSVs. In addition, Site 86 is an industrial area that consists primarily of mowed grass and asphalt. Therefore, an ecologically diverse population of terrestrial receptors is not expected to inhabit the site, and should not be impacted from site-related contaminants.

7.13 References

Agency for Toxic Substances and Disease Registry (ASTDR). 1989. Toxicological Profile for Naphthalene/2-Methynaphthalene - Draft. Prepared by Life Systems, Inc, for the US Department of Health and Human Services.

Arthur and Alldredge. 1979. Public Health Evaluation and Ecological Assessment. Martin Marrietta Astronautics Group, Waterton Facility, Vol. II of III, Appendix A and B. Cited in Scarano, 1993.

Baes, C.F., Sharp, A.L., and R.W. Shor. September 1984. "Review and Analysis of Parameters for Assessing Transport of Environmentally Released Radionuclides through Agriculture." Oak Ridge National Laboratory.

Beyer, N., E. Connor, and S. Gerould. 1993. "Estimates of Soil Ingestion by Wildlife". Patuxent Wildlife Research Center, Laurel, MD.

Dee, J.C. November, 1991. "Methodology For Assessing Potential Risks To Deer Populations: A Case Study at a Superfund Site". Paper presented at the 1991 Annual Meeting of the Society of Environmental Toxicology and Chemistry. Abstract No. 426.

Hulzebos, E.M., D.M.M. Adema, E.M. Dirven-van Breemen, L. Henzen, W.A. Van Dis, H.A. Herbold, J.A. Hoekstra, R. Baerselman, and C.A.M. Van Gestel 1993. "Phytotoxicity Studies with *Lactuca sativa* in Soil and Nutrient Solution". Environmental Toxicology and Chemistry. Vol. 12, No. 6:1079-1094.

Menzie, C.A., Cura J. and J. Freshman. January 1993. Evaluating Ecological Risks and Developing Remedial Objectives at Forested Wetland Systems in New England. Paper contained in: Application of Ecological Risk Assessment To Hazardous Waste Site Remediation. Water Environmental Federation.

Montgomery, J.H. and L.M. Welkon. 1990. Groundwater Chemicals Desk Reference. Lewis Publishers, Inc. Chelsea, Michigan.

Nagy, Kenneth. 1987. "Field Metabolic Rate and Food Requirement Scaling in Mammals and Birds. Ecological Monographs." 57(2). pp. 111-128.

NAS. 1992. Subcommittee on Mineral Toxicity in Animals. Mineral Tolerance of Domestic Animals. National Academy of Sciences. Washington, D.C. pp 5-7.

Opresko, D.M., B.E. Sample, and G.W. Suter II. 1994. Toxicological Benchmarks for Wildlife, 1994 Revisions. Prepared for the US Department of Energy, Office of Environmental Restoration and Waste Management. September, 1994. ES/ER/TM-86/R1.

SCDM. 1991. Superfund Chemical Data Matrix. United States Environmental Protection Agency Hazardous Site Evaluation Division. December 1991.

Scarano, Louis, J. Ph.D. and Daniel M. Woltering, Ph.D. January 1993. "Terrestrial and Aquatic Eco-Assessment for A RCRA Hazardous Waste Site". Paper contained in: Application of Ecological Risk Assessment To Hazardous Waste Site Remediation. Cited in WEF, 1993.

Travis, Curtis C. and Angela Arms. 1988. Bioconcentration of Organics in Beef, Milk, and Vegetation. Environmental Science Technology. Vol. 22, No. 3.

USEPA, U.S. Environmental Protection Agency. January 26, 1995a. "Toxic Substance Spreadsheet". Region IV, Atlanta, Georgia.

USEPA, U.S. Environmental Protection Agency. January 19, 1995b. "Region III BTAG Screening Levels". Region III, Philadelphia, PA.

USEPA, U.S. Environmental Protection Agency. September 26, 1994. Ecological Risk Assessment Guidance for Superfund: Process for Designing and Conducting Ecological Risk Assessments. Review Draft Environmental Response Team, Edison NJ

USEPA, US Environmental Protection Agency. September 1993a. Sediment Quality Criteria for the Protection of Benthic Organisms- Acenaphthene. Office of Science and Technology. Health and Ecological Criteria Section. Washington, D.C. EPA-822-R-93-013.

USEPA, US Environmental Protection Agency. September 1993b. Sediment Quality Criteria for the Protection of Benthic Organisms- Fluoranthene. Office of Science and Technology. Health and Ecological Criteria Section. Washington, D.C. EPA-822-R-93-012.

USEPA, US Environmental Protection Agency. September 1993c. Sediment Quality Criteria for the Protection of Benthic Organisms- Phenanthrene. Office of Science and Technology. Health and Ecological Criteria Section. Washington, D.C. EPA-822-R-93-014.

USEPA, US Environmental Protection Agency. September 1993d. Sediment Quality Criteria for the Protection of Benthic Organisms- Dieldrin. Office of Science and Technology. Health and Ecological Criteria Section. Washington, D.C. EPA-822-R-93-015.

USEPA, U.S. Environmental Protection Agency. December 1993e. Wildlife Exposure Factors Handbook. Office of Research and Development. Washington, D.C. EPA/600/R-93/187a.

USEPA. U.S. Environmental Protection Agency. February 1992. Framework for Ecological Risk Assessment. United States Environmental Protection Agency. Risk Assessment Forum. EPA/630/R-92/001.

USEPA, U.S. Environmental Protection Agency. June 1991. National Functional Guidelines for Organic Data Review. Draft. USEPA Contract Laboratory Program.

USEPA. U.S. Environmental Protection Agency. December 1989a. Risk Assessment Guidance for Superfund. Volume I. Human Health Evaluation Manual (Part A). Interim Final EPA/540/1-89/002.

USEPA. U.S. Environmental Protection Agency. March 1989b. Risk Assessment Guidance for Superfund. Volume II. Environmental Evaluation Manual Interim Final. Office of Solid Waste and Emergency Response. Washington, D.C. EPA/540/1-89-001.

USEPA. U.S. Environmental Protection Agency. March 1989c. Ecological Assessment of Hazardous Waste Sites: A Field and Laboratory Reference. Environmental Research Laboratory, Corvallis, OR. EPA/600/3-89/013.

USEPA. U.S. Environmental Protection Agency. October 1986. Chemical, Physical, and Biological Properties of Compounds Present at Hazardous Waste Sites. Office of Solid Waste and Remedial Response. Washington D.C. EPA/540/1-86/060.

Water Environment Federation (WEF). 1989. Application of Ecological Risk Assessment to Hazardous Waste Site Remediation. Based on a January 10, 1993 Workshop., 601 Wythe Street, Alexandria, VA 22314-1994.

Will, M.E. and Suter, G.W. II. 1994a. Toxicological Benchmarks for Screening Potential Contaminants of Concern for Effects on Soil and Litter Invertebrates and Heterotrophic Process. Environmental Sciences Division, Oak Ridge National Laboratory.

Will, M.E. and Suter, G.W. II. 1994b. Toxicological Benchmarks for Screening Potential Contaminants of Concern for Effects on Terrestrial Plants. Environmental Sciences Division, Oak Ridge National Laboratory.

SECTION 7.0 TABLES

TABLE 7-1

CONTAMINANTS OF POTENTIAL CONCERN IN EACH MEDIA
 SITE 86, ABOVEGROUND STORAGE TANK AREA
 REMEDIAL INVESTIGATION CTO-0303
 MCAS, NEW RIVER, NORTH CAROLINA

Contaminant	Surface Soil
Volatiles	
Acetone	X
Toluene	X
Xylenes	X
Semivolatiles	
Acenaphthene	X
Anthracene	X
Benzo(a)anthracene	X
Benzo(b)fluoranthene	X
Benzo(k)fluoranthene	X
Benzo(g,h,i)perylene	X
Benzo(a)pyrene	X
Bis(2-ethylhexyl)phthalate	X
Butylbenzylphthalate	X
Carbazole	X
Chrysene	X
Dibenz(a,h)anthracene	X
Dibenzofuran	X
Fluoranthene	X
Fluorene	X
Indeno(1,2,3-cd)pyrene	X
2-Methylnaphthalene	X
Naphthalene	X
Phenanthrene	X
Pyrene	X

TABLE 7-1 (Continued)

CONTAMINANTS OF POTENTIAL CONCERN IN EACH MEDIA
SITE 86, ABOVEGROUND STORAGE TANK AREA
REMEDIAL INVESTIGATION CTO-0303
MCAS, NEW RIVER, NORTH CAROLINA

Contaminant	Surface Soil
Pesticides/PCBs	
Aldrin	X
4,4'-DDE	X
4,4'-DDD	X
4,4'-DDT	X
Dieldrin	X
Heptachlor epoxide	X
Inorganics	
Aluminum	X
Arsenic	X
Barium	X
Cadmium	X
Chromium	X
Copper	X
Iron	X
Lead	X
Manganese	X
Mercury	X
Nickel	X
Vanadium	X
Zinc	X

TABLE 7-2

**PHYSICAL/CHEMICAL CONTAMINANTS OF THE COPCS
SITE 86, ABOVEGROUND STORAGE TANK AREA
REMEDIAL INVESTIGATION CTO-0303
MCAS, NEW RIVER, NORTH CAROLINA**

Contaminant of Potential Concern	BCF	Organic Carbon Partition Coefficient (mL/g)	Log Octanol/Water Coefficient	Biotransfer Factors		
				Bv ⁽¹⁾⁽²⁾	Br ⁽¹⁾⁽²⁾	Bb ⁽¹⁾⁽²⁾
Volatiles						
Acetone	0.69 ⁽⁴⁾	2.2 ⁽⁵⁾	-0.24 ⁽⁶⁾	5.30e+01	5.30e+01	1.45e-08
Toluene	10.70 ⁽³⁾	300 ⁽⁵⁾	2.70 ⁽⁶⁾	1.07e+00	1.07e+00	1.26e-05
Xylenes	2.20 ⁽⁴⁾	240 ⁽⁵⁾	3.20 ⁽⁶⁾	5.48e-01	5.48e-01	3.98e-05
Semivolatiles						
Acenaphthene	242 ⁽³⁾	5,754 ⁽¹⁰⁾	3.8 ⁽¹⁰⁾	2.46e-01	2.46e-01	1.58e-04
Anthracene	30 ⁽³⁾	14,000 ⁽⁵⁾	4.5 ⁽⁶⁾	9.70e-02	9.70e-02	7.94e-04
Benzo(a)anthracene	30 ⁽³⁾	1,380,000 ⁽⁵⁾	5.7 ⁽⁶⁾	2.00e-02	2.00e-02	1.26e-02
Benzo(a)pyrene	30 ⁽³⁾	5,500,000 ⁽⁵⁾	6.0 ⁽⁶⁾	1.30e-02	1.30e-02	2.51e-02
Benzo(b)fluoranthene	30 ⁽³⁾	550,000 ⁽⁵⁾	6.6 ⁽⁶⁾	6.00e-03	6.00e-03	1.00e-01
Benzo(k)fluoranthene	30 ⁽³⁾	550000	6.1 ⁽⁵⁾	1.20e-02	1.20e-02	3.16e-02
Benzo(g,h,i)perylene	30 ⁽³⁾	1,600,000 ⁽⁵⁾	6.5 ⁽⁵⁾	7.00e-03	7.00e-03	7.94e-02
Bis(2-ethylhexyl)phthalate	130 ⁽³⁾	100,000 ⁽⁷⁾	5.1 ⁽⁶⁾	4.40e-02	4.40e-02	3.16e-03
Butylbenzylphthalate	414 ⁽³⁾	ND	4.9 ⁽⁶⁾	5.70e-02	5.70e-02	2.00e-03
Carbazole	ND	ND	6 ⁽⁸⁾	1.30e-02	1.30e-02	2.51e-02
Chrysene	30 ⁽³⁾	200,000 ⁽⁵⁾	5.7 ⁽⁶⁾	2.00e-02	2.00e-02	1.26e-02
Dibenz(a,h)anthracene	30 ⁽³⁾	3,300,000 ⁽⁵⁾	6.5 ⁽⁶⁾	7.00e-03	7.00e-03	7.94e-02
Dibenzofuran	ND	ND	6 ⁽⁸⁾	1.30e-02	1.30e-02	2.51e-02
Fluoranthene	1,150 ⁽³⁾	100,000 ⁽¹¹⁾	5.1 ⁽¹¹⁾	4.40e-02	4.40e-02	3.90e-03
Fluorene	30 ⁽³⁾	7,300 ⁽⁵⁾	4.2 ⁽⁶⁾	1.45e-01	1.45e-01	3.98e-04
Indeno(1,2,3-cd)pyrene	30 ⁽³⁾	1,600,000 ⁽⁵⁾	6.5 ⁽⁶⁾	7.00e-03	7.00e-03	8.13e-02
2-Methylnaphthalene	10.5 ⁽⁹⁾	1,072 ⁽⁹⁾	3.6 ⁽⁹⁾	3.22e-01	3.22e-01	1.00e-04
Naphthalene	10.5 ⁽³⁾	1,072 ⁽¹²⁾	3.6 ⁽⁶⁾	3.22e-01	3.22e-01	1.00e-04
Phenanthrene	30 ⁽³⁾	28,840 ⁽¹³⁾	4.5 ⁽¹³⁾	9.70e-02	9.70e-02	7.94e-04
Pyrene	30 ⁽³⁾	38,000 ⁽⁵⁾	5.3 ⁽⁶⁾	3.30e-02	3.30e-02	5.01e-03
Pesticides/PCBs						
Aldrin	4,670 ⁽³⁾	96,000 ⁽⁵⁾	3 ⁽⁶⁾	7.14e-01	7.14e-01	2.51e-05
4,4'-DDD	53,600 ⁽³⁾	770,000 ⁽⁵⁾	6 ⁽⁶⁾	1.32e-02	1.32e-02	2.51e-02
4,4'-DDE	53,600 ⁽³⁾	4,400,000 ⁽⁵⁾	5.7 ⁽⁶⁾	2.00e-02	2.00e-02	1.26e-02
4,4'-DDT	53,600 ⁽³⁾	243,000 ⁽⁵⁾	6.4 ⁽⁶⁾	8.00e-03	8.00e-03	6.31e-02
Dieldrin	4,670 ⁽³⁾	177,828 ⁽¹⁴⁾	5.3 ⁽¹⁴⁾	3.20e-02	3.20e-02	5.50e-03
Heptachlor epoxide	11,200 ⁽³⁾	220 ⁽⁵⁾	4.3 ⁽⁶⁾	1.27e-01	1.27e-01	5.01e-04

TABLE 7-2 (Continued)

**PHYSICAL/CHEMICAL CHARACTERISTICS OF THE COPCS
SITE 86, ABOVEGROUND STORAGE TANK AREA
REMEDIAL INVESTIGATION CTO-0303
MCAS, NEW RIVER, NORTH CAROLINA**

Contaminant of Potential Concern	BCF	Organic Carbon Partition Coefficient (mL/g)	Log Octanol/Water Coefficient	Biotransfer Factors		
				Bv ⁽¹⁾⁽²⁾	Br ⁽¹⁾⁽²⁾	Bb ⁽¹⁾⁽²⁾
Inorganics						
Aluminum	231 ⁽⁴⁾	ND	ND	4.00e-03	6.50e-04	1.50e-03
Arsenic	44 ⁽³⁾	ND	ND	4.00e-02	6.00e-03	2.00e-03
Barium	8 ⁽⁴⁾	ND	ND	1.50e-01	1.50e-02	1.50e-04
Cadmium	64 ⁽³⁾	ND	ND	5.50e-01	1.50e-01	5.50e-04
Chromium	16 ⁽³⁾	ND	ND	7.50e-03	4.50e-03	5.50e-03
Copper	36 ⁽³⁾	ND	ND	4.00e-01	2.50e-01	1.00e-02
Iron	ND	ND	ND	4.00e-03	1.00e-03	2.00e-02
Lead	49 ⁽³⁾	ND	ND	4.50e-02	9.00e-03	3.00e-04
Manganese	35 ⁽⁴⁾	ND	ND	2.50e-01	5.00e-02	4.00e-04
Mercury	5,500 ⁽³⁾	ND	ND	9.00e-01	2.00e-01	2.50e-01
Nickel	47 ⁽³⁾	ND	ND	6.00e-02	6.00e-02	6.00e-03
Vanadium	ND	ND	ND	5.50e-03	3.00e-03	2.50e-03
Zinc	47 ⁽³⁾	ND	ND	1.50e+00	9.00e-01	1.00e-01

Notes:

- (1) Baes, 1984 for the inorganics
- (2) The organics were calculated using Travis, 1988
- (3) USEPA, 1995a (Region IV)
- (4) USEPA, 1995b (Region III)
- (5) USEPA, 1986.
- (6) SCDM, 1991.
- (7) Montgomery and Welkon, 1990.
- (8) Used benzo(a)pyrene Kow
- (9) Used naphthalene values
- (10) USEPA, 1993a (Sediment Quality Criteria for Acenaphthene)
- (11) USEPA, 1993b (Sediment Quality Criteria for Fluoranthene)
- (12) ASTDR, 1989 (Toxicological Profile for Naphthalene/2-Methynaphthalene)
- (13) USEPA, 1993c (Sediment Quality Criteria for Phenanthrene)
- (14) USEPA, 1993d (Sediment Quality Criteria for Dieldrin)

BCF = Bioconcentration Factor

ND = No Data

Bv = Biotransfer factor for vegetation (stems, leaves)

Br = Biotransfer factor for vegetation (berries, fruits)

Bb = Biotransfer factor for beef

TABLE 7-3

FREQUENCY AND RANGE OF CONTAMINANT DETECTIONS
 COMPARED TO SOIL FLORA AND FAUNA SCREENING VALUES
 SITE 86, ABOVEGROUND STORAGE TANK AREA
 REMEDIAL INVESTIGATION CTO-0303
 MCAS, NEW RIVER, NORTH CAROLINA

Contaminant	Soil Flora and Fauna Screening Values ⁽¹⁾				Contaminant Frequency/Range		No. of Positive Detects Above Lowest Screening Value
	Plant	Earthworm	Invertebrate	Microorganisms and Microbial Processes	No. of Positive Detects/No. of Samples	Range of Positive Detects	
Volatiles (µg/kg)							
Acetone	NE	NE	NE	NE	1/18	28J	NA
Toluene	200,000	100 ⁽²⁾	100 ⁽²⁾	NE	1/18	25	0
Xylene	>1000 ⁽²⁾	NE	NE	NE	1/18	5J	0
Semivolatiles (µg/kg)							
Acenaphthene	NE	100 ⁽²⁾	100 ⁽²⁾	NE	4/18	50J-580	2
Anthracene	NE	100 ⁽²⁾	100 ⁽²⁾	NE	5/18	43J-790	3
Benzo(a)anthracene	NE	100 ⁽²⁾	100 ⁽²⁾	NE	10/18	70J-2,100	6
Benzo(b)fluoranthene	NE	100 ⁽²⁾	100 ⁽²⁾	NE	8/18	110J-2,300	8
Benzo(k)fluoranthene	NE	100 ⁽²⁾	100 ⁽²⁾	NE	8/18	57J-950	5
Benzo(g,h,i)perylene	NE	100 ⁽²⁾	100 ⁽²⁾	NE	7/18	57J-590J	4
Benzo(a)pyrene	NE	20,000 ⁽²⁾	25,000	NE	10/18	48J-1,800	0
Bis(2-ethylhexyl)phthalate	NE	NE	NE	NE	2/18	47J-86J	NA
Butylbenzylphthalate	NE	NE	NE	NE	4/18	49J-380	NA
Carbazole	NE	NE	NE	NE	5/18	39J-480	NA
Chrysene	NE	100 ⁽²⁾	100 ⁽²⁾	NE	9/18	86J-2,100	8
Dibenzo(a,h)anthracene	NE	100 ⁽²⁾	100 ⁽²⁾	NE	4/18	37J-290J	2
Dibenzofuran	NE	NE	NE	NE	1/18	220J	NA
Fluoranthene	NE	100 ⁽²⁾	100 ⁽²⁾	NE	9/18	39J-3,500	8
Fluorene	NE	30,000	100 ⁽²⁾	NE	3/18	43J-440	1

TABLE 7-3 (Continued)

FREQUENCY AND RANGE OF CONTAMINANT DETECTIONS
 COMPARED TO SOIL FLORA AND FAUNA SCREENING VALUES
 SITE 86, ABOVEGROUND STORAGE TANK AREA
 REMEDIAL INVESTIGATION CTO-0303
 MCAS, NEW RIVER, NORTH CAROLINA

Contaminant	Soil Flora and Fauna Screening Values ^(a)				Contaminant Frequency/Range		No. of Positive Detects Above Lowest Screening Value
	Plant	Earthworm	Invertebrate	Microorganisms and Microbial Processes	No. of Positive Detects/No. of Samples	Range of Positive Detections	
Indeno(1,2,3-cd)pyrene	NE	100 ^(a)	100 ^(a)	NE	7/18	67J-1,100	4
2-Methylnaphthalene	NE	NE	NE	NE	1/18	80J	NA
Naphthalene	100 ^(a)	100 ^(a)	100 ^(a)	NE	1/18	85J	0
Phenanthrene	NE	100 ^(a)	100 ^(a)	NE	8/18	64J-2,700	5
Pyrene	NE	100 ^(a)	100 ^(a)	NE	10/18	110J-3,100	10
Pesticides/PCBs (µg/kg)							
Aldrin	NE	100 ^(a)	100 ^(a)	NE	1/11	2J	0
4',4-DDD	NE	100 ^(a)	100 ^(a)	NE	5/11	5.2J-9.6J	0
4',4-DDE	NE	100 ^(a)	100 ^(a)	NE	11/11	4.9J-38J	0
4',4-DDT	NE	4 ^(a)	4 ^(a)	NE	10/11	4.3J-27J	10
Dieldrin	NE	<100 ^(a)	<100 ^(a)	NE	10/11	4.8-44	0
Heptachlor epoxide	NE	<100 ^(a)	<100 ^(a)	NE	1/11	5.2J	0
Inorganics (mg/kg)							
Aluminum	50	NE	NE	600	11/11	4,590-6,660	11
Arsenic	10	60	NE	100	9/11	0.53-1.8	0
Barium	500	440 ^(a)	440 ^(a)	3,000	11/11	7.7-133	0
Cadmium	3	20	3	20	5/11	0.48-1.1	0
Chromium	1	0.4	0.0075 ^(a)	10	11/11	5.1-10.1J	11
Copper	100	50	20	100	10/11	1.1-53.4J	1
Iron	100 ^(a)	NE	3,515	200	11/11	1,670-5,580	11

TABLE 7-3 (Continued)

FREQUENCY AND RANGE OF CONTAMINANT DETECTIONS
 COMPARED TO SOIL FLORA AND FAUNA SCREENING VALUES
 SITE 86, ABOVEGROUND STORAGE TANK AREA
 REMEDIAL INVESTIGATION CTO-0303
 MCAS, NEW RIVER, NORTH CAROLINA

Contaminant	Soil Flora and Fauna Screening Values ⁽¹⁾				Contaminant Frequency/Range		No. of Positive Detects Above Lowest Screening Value
	Plant	Earthworm	Invertebrate	Microorganisms and Microbial Processes	No. of Positive Detects/No. of Samples	Range of Positive Detections	
Lead	50	500	300	900	11/11	12.4J-43.1	0
Manganese	500	330 ⁽²⁾	330 ⁽²⁾	100	11/11	5.5-21.7	0
Mercury	0.3	0.1	300	30	1/11	0.16	1
Nickel	30	200	NE	90	8/11	1.3-22.3	0
Vanadium	2	58 ⁽²⁾	58 ⁽²⁾	20	11/11	7.9-92.7	11
Zinc	50	200	500	100	11/11	5.4-39.9J	0

Notes:

- (1) Will and Suter, 1994a and 1994b unless indicated otherwise (Values presented for plants, earthworms, and microorganisms and microbial processes are benchmarks below which adverse impacts to these species are not expected. Values for invertebrates are No Observed Effects Concentrations, however, they are based on less data than the benchmarks)
- (2) USEPA, 1995b (Region III BTAG Soil Screening Values for Soil Fauna)

TABLE 7-4

EXPOSURE PARAMETERS FOR CHRONIC DAILY INTAKE MODEL
 SITE 86, ABOVEGROUND STORAGE TANK AREA
 REMEDIAL INVESTIGATION CTO-0303
 MCAS, NEW RIVER, NORTH CAROLINA

Exposure Parameter	Units	White-Tailed Deer	Eastern Cottontail Rabbit	Bobwhite Quail	Red Fox	Small Mammal (Meadow Vole)
Food Source Ingestion	NA	Vegetation 100%	Vegetation 100%	Vegetation 100%	Small Mammals 80% Vegetation 20%	Vegetation 100%
Feeding Rate	kg/day	1.6 ⁽²⁾	0.237 ⁽⁴⁾	0.0135 ⁽³⁾	0.601 ⁽³⁾	0.112 ⁽³⁾
Incident Soil Ingestion	kg/day	0.0185 ⁽¹⁾	0.0057 ⁽⁵⁾	0.0011 ⁽⁵⁾	0.0168 ⁽⁵⁾	0.00269 ⁽⁵⁾
Rate of Drinking Water Ingestion	L/day	1.1 ⁽²⁾	0.119 ⁽³⁾	0.0191 ⁽³⁾	0.385 ⁽³⁾	0.0652 ⁽³⁾
Rate of Vegetation Ingestion	kg/day	1.6	0.237	0.0135	0.12	0.112
Body Weight	kg	45.4 ⁽²⁾	1.229 ⁽³⁾	0.174 ⁽³⁾	4.54 ⁽³⁾	0.3725 ⁽³⁾
Rate of Small Mammal Ingestion	kg/day	NA	NA	NA	0.48	NA
Rate of Fish Ingestion	kg/day	NA	NA	NA	NA	NA
Home Range Size	acres	454 ⁽²⁾	9.30 ⁽³⁾	26.24 ⁽³⁾	1,245 ⁽³⁾	0.032 ⁽³⁾

Notes:

NA = Not Applicable

⁽¹⁾ Arthur and Alldridge, 1979

⁽²⁾ Dee, 1991

⁽³⁾ USEPA, 1993e

⁽⁴⁾ Opresko, et.al., 1994

⁽⁵⁾ Beyer, 1993

⁽⁶⁾ Nagy, 1987

TABLE 7-5

**TERRESTRIAL INTAKE MODEL QUOTIENT INDEX
SITE 86, ABOVEGROUND STORAGE TANK AREA
REMEDIAL INVESTIGATION, CTO-0303
MCAS, NEW RIVER, NORTH CAROLINA**

Contaminant of Potential Concern	Red Fox	Bobwhite Quail	Cottontail Rabbit	Whitetail Deer
Acetone	4.01e-06	8.72e-05	2.52e-03	3.14e-05
Toluene	2.82e-08	5.85e-07	1.61e-05	1.98e-07
Xylenes (total)	1.29e-09	2.57e-08	6.75e-07	8.22e-09
Acenaphthene	3.67e-07	6.79e-06	1.62e-04	1.92e-06
Anthracene	1.00e-07	1.65e-06	3.23e-05	3.61e-07
Benzo(a)anthracene	1.23e-05	1.70e-04	2.12e-03	1.89e-05
Benzo(a)pyrene	1.24e-05	1.66e-04	1.88e-03	1.56e-05
Benzo(b)fluoranthene	1.27e-05	1.63e-04	1.61e-03	1.17e-05
Benzo(g,h,i)perylene	6.05e-06	7.82e-05	7.85e-04	5.83e-06
Benzo(k)fluoranthene	7.65e-06	1.02e-04	1.12e-03	9.08e-06
Bis(2-ethylhexyl)phthalate	4.28e-06	1.86e-05	9.94e-04	1.01e-05
Butylbenzylphthalate	2.08e-07	3.20e-06	5.39e-05	5.69e-07
Carbazole	2.72e-05	5.30e-04	1.39e-02	1.70e-04
Chrysene	1.26e-05	1.74e-04	2.16e-03	1.93e-05
Dibenz(a,h)anthracene	5.19e-06	6.70e-05	6.73e-04	5.00e-06
Dibenzofuran	2.11e-05	4.11e-04	1.08e-02	1.32e-04
Fluoranthene	2.32e-06	3.45e-05	5.41e-04	5.51e-06
Fluorene	3.67e-07	6.36e-06	1.37e-04	1.58e-06
Indeno(1,2,3-cd)pyrene	8.04e-06	1.04e-04	1.04e-03	7.70e-06
2-Methylnaphthalene	6.03e-08	1.15e-06	2.85e-05	3.42e-07
Naphthalene	6.41e-08	1.22e-06	3.03e-05	3.64e-07
Phenanthrene	2.21e-07	3.64e-06	7.13e-05	7.97e-07
Pyrene	2.58e-06	3.74e-05	5.38e-04	5.26e-06
Aldrin	8.90e-07	5.53e-05	1.48e-03	1.38e-07
4,4'-DDE	3.94e-07	1.35e-04	6.78e-05	6.04e-07
4,4'-DDD	1.18e-07	3.92e-05	1.79e-05	1.49e-07
4,4'-DDT	3.18e-07	1.02e-04	4.24e-05	3.21e-07
Dieldrin	3.32e-05	1.72e-04	2.07e-02	3.05e-07
Heptachlor epoxide	8.69e-05	1.48e-03	3.10e-02	3.54e-04
Aluminum	1.29e-03	6.85e-02	4.12e-01	1.53e-03
Arsenic	3.64e-04	4.11e-05	1.03e-03	2.77e-05
Barium	4.45e-03	1.73e-02	2.39e-01	7.41e-03
Cadmium	1.44e-04	3.20e-04	3.92e-01	1.28e-02
Chromium	3.72e-05	2.11e-05	1.37e-04	2.77e-06
Copper	7.45e-05	1.56e-03	3.80e-02	2.46e-03
Iron	9.53e-04	9.69e-03	1.16e-01	1.08e-03

TABLE 7-5 (Continued)

TERRESTRIAL INTAKE MODEL QUOTIENT INDEX
 SITE 86, ABOVEGROUND STORAGE TANK AREA
 REMEDIAL INVESTIGATION, CTO-0303
 MCAS, NEW RIVER, NORTH CAROLINA

Contaminant of Potential Concern	Red Fox	Bobwhite Quail	Cottontail Rabbit	Whitetail Deer
Lead	5.53e-05	2.39e-03	3.94e-02	1.08e-03
Manganese	4.66e-05	6.77e-05	5.16e-03	3.29e-04
Mercury	2.18e-05	1.01e-03	1.69e-02	5.76e-04
Nickel	3.92e-06	2.74e-04	1.80e-02	5.10e-04
Vanadium	8.45e-04	4.46e-04	7.96e-01	3.07e-04
Zinc	1.34e-03	1.38e-03	4.91e-02	1.62e-03
Total Quotient Index	9.89e-03	1.07e-01	2.22e+00	3.05e-02

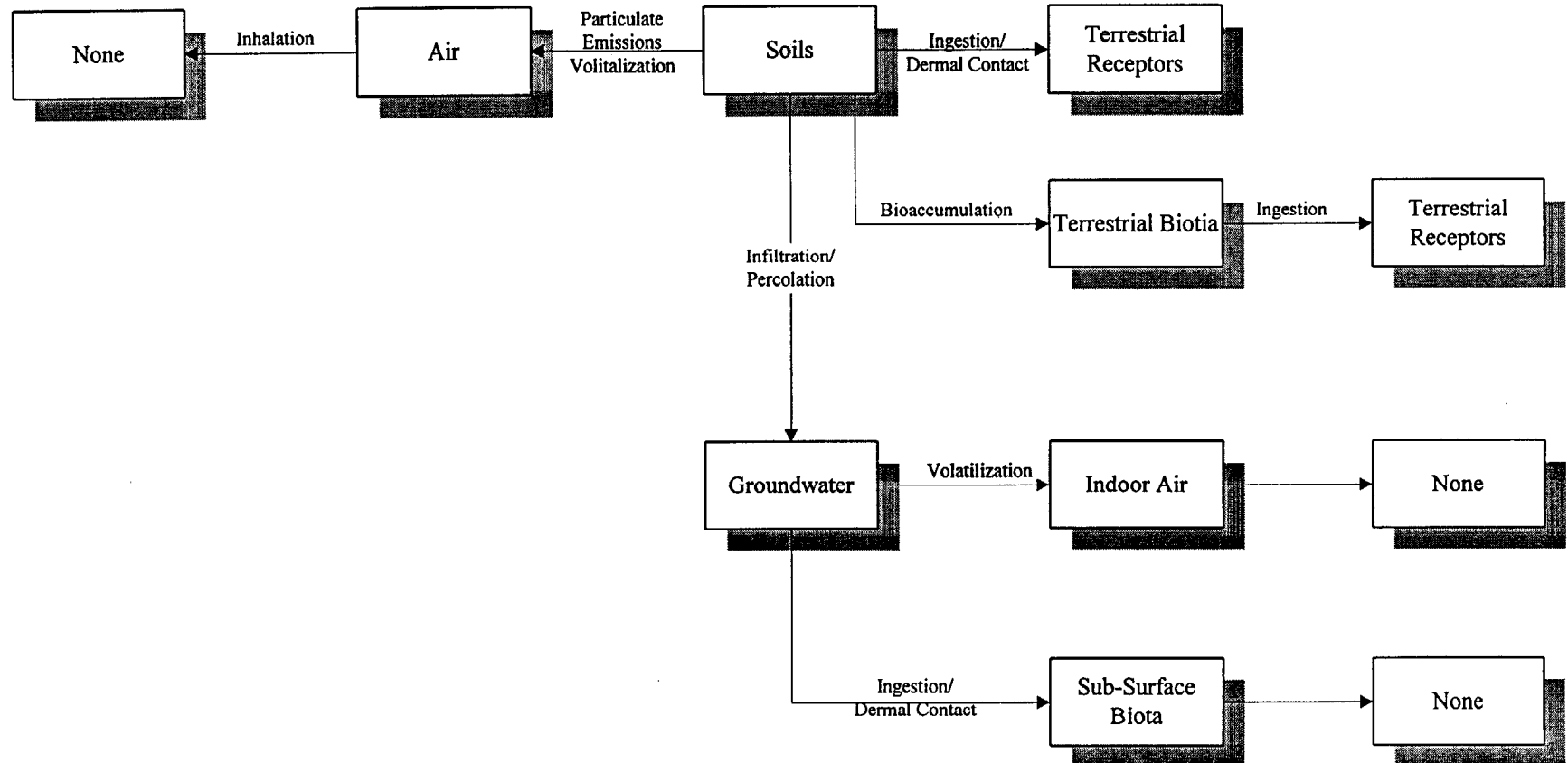
Notes:

Shaded boxes are Quotient Indices that exceed "1"

SECTION 7.0 FIGURES

FIGURE 7-1

CONCEPTUAL EXPOSURE MODEL FOR ECOLOGICAL RECEPTORS
SITE 86, ABOVEGROUND STORAGE TANK AREA



8.0 CONCLUSIONS AND RECOMMENDATIONS

8.1 Conclusions

The following conclusions were derived from the RI conducted at Site 86:

- SVOCs, primarily PAHs, were detected throughout the site especially in surface soils. A number of potential sources of the PAHs have been identified, including the site's present use as an heavy equipment, vehicle storage and maintenance area, and the former ASTs.
- Metals were detected in the site soils, including cadmium, chromium, copper, lead, mercury, mercury, nickel, and zinc at concentrations above base-specific background ranges. One possible source of the metals is the waste oils formerly stored in the ASTs.
- VOCs were detected in site groundwater. The maximum VOC detections were located to the southeast of the former ASTs. The VOC plume is well-defined horizontally. The vertical portion of the plume is limited to the surficial aquifer. The VOCs have migrated to the lower portion of the surficial aquifer but have not migrated into the underlying Castle Hayne aquifer. The VOCs appear to be migrating in the general direction of groundwater flow, which is north-northeast.
- Iron, lead, arsenic, and antimony concentrations in groundwater yielded unacceptable risks to human receptors.
- No significant adverse risks to ecological receptors were calculated at Site 86. Site 86 is predominantly an industrial site consisting mainly of grass and asphalt cover.

8.2 Recommendations

The following recommendations are provided based on the RI finding:

- Groundwater remedial actions are warranted due to the presence of elevated volatile organic compounds above the state and federal standards. Because the plume is well-defined both horizontally and vertically, and limited to the Site 86 area in extent, extraction and treatment appears to be a viable cleanup alternative.